

## IMPROVEMENT OF THE DRIVE OF THE DRYER 2SB-10 IN ORDER TO REDUCE ITS ENERGY CONSUMPTION

R.K. Jamolov

Jizzakh Polytechnic Institute

A.M. Shodmonkulov

Jizzakh Polytechnic Institute

### Annotation

The article presents the results of research work carried out at Paxtasanoatilmiymarkazi (cotton industry scientific center) JSC to improve the drive of the 2SB-10 drum-type cotton dryer. A scheme of a new chain drive has been developed, the leading part of the developed drive has been manufactured and tested in the conditions of the scientific center.

**Keywords:** dryer drum, drive, chain drive, sprocket, power, rotation, speed.

### Introduction

It is known that the 2SB-10 drum type dryers used in the cotton ginning industry have a very complex and energy-intensive drive device, which uses a 13 kW electric motor and a massive hanging gearbox [1, 2].

The first attempts to improve the drive of a drum-type cotton dryer were carried out by the researcher G.L. Hamburg [3], the scheme of which is shown in Fig. 1

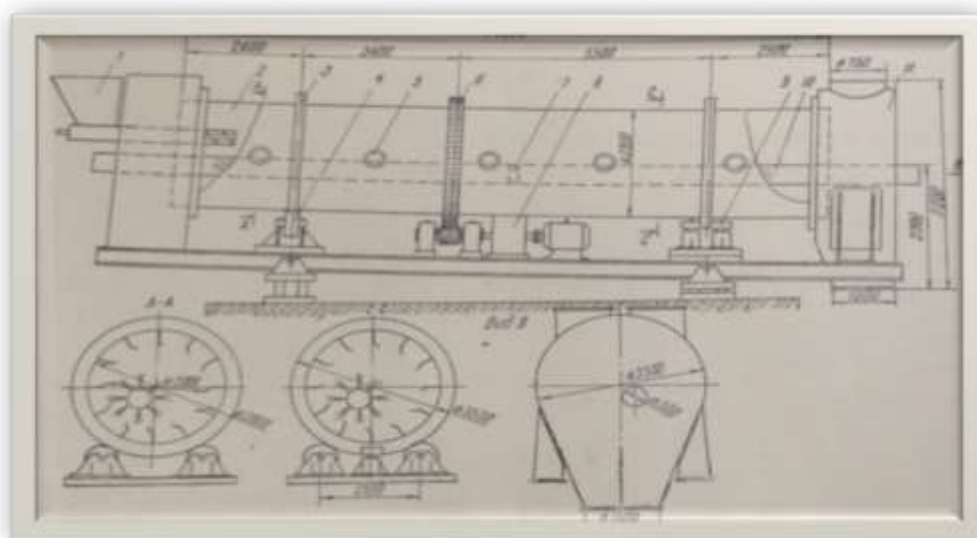

Fig.1. Scheme of a drying drum with an improved drive and a radial supply of heat carrier

1-screw feeder, 2-drum body, 3-bandage, 4-support rollers, 5-inspection hatches, 6-tooth crown, 7-movable gate, 8-drive with gearbox, 9-thrust rollers, 10-perforated pipe, 11-chamber unloading, 12-compacting device

As can be seen from Figure 1 on the developed drive, a large ring gear is fixed on the shell of the drum, and a small driving ring gear is engaged to it. The proposed drive of the dryer due to design flaws, as well as the imperfection of the gear and roller bearings, was not used in production, since during the operation of the dryer drum, the dried raw cotton inside the drum is not evenly distributed along the length of the drum [4]. Therefore, variable loads can be created on the gear rims, resulting in tooth breakage.

However, the idea proposed in this work is a valuable material, the use of which is possible with the improvement of the drive of the 2SB-10 dryer drum, designed for drying cotton in ginneries.

Taking into account the analysis of previously performed work in the laboratory of drying, cleaning of raw cotton, Paxtasanoatilmiyarkazi (cotton industry scientific center) JSC developed a drive scheme for a 2SB-10 cotton dryer, the scheme of which is shown in Fig. 2.

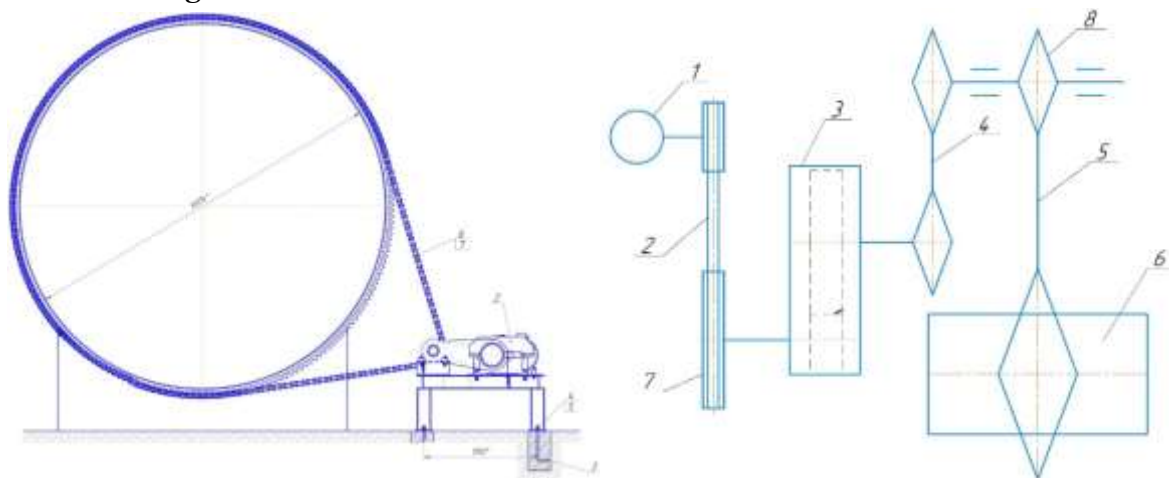

Fig.2. Diagram of a dryer drum with an improved drive (left) and a separate diagram of the leading drive (right).

1-electric motor, 2-belt transmission, 3-reducer, 4, 5-chain transmission, 6-dryer 2SB-10, 7-pulley, 8-sprocket.

The advantage of the developed drive is that the generated variable loads from the side of the dryer drum are ground using the chain drive (that is, with the chain length adjustment and the choice of center distance) [5].

According to the developed drive scheme, the beater was assembled with a leading drive of the drum, consisting mainly of an electric motor with a power of 7.5 kW, a rotation speed of 1430 rpm, a gearbox with a gear ratio of 1 to 31.5 (Fig. 3). Taking into account the recommended speed of rotation of the drum dryer, which is equal to 10

rpm, the diameters of the pulleys and sprockets installed on the drive drive were selected.



Fig.3. General view of the drive to the drum dryer.

After manufacturing, the driving drive of the drum was assembled on a separate frame (Fig. 3), work was completed to complete it with an engine, belts, bearings, etc. The complete drum drive was checked for operability, the rotational speed of the main sprocket was determined, which should provide the required rotational speeds of the drum dryer. Currently, according to the developed schemes, a driven ring gear is being manufactured to assemble it on the shell of the 2-SB-10 drying drum. The manufactured and assembled drive is planned to be installed on a 2SB-10 dryer drum at one of the selected cotton gins, its main parameters will be justified.

### Conclusion

1. The main disadvantage of the drying drum type 2SB-10 is the use in its design of an unreasonable drive for rotating the drying chamber-drum. The dryer drum drive type 2SB-10 consists of a massive gearbox and an electric drive with a power of 13 kW. At present, such a steel drive system is not economically viable.
2. The leading drive of the dryer drum was manufactured and assembled, the introduction of which reduces the power required to rotate the dryer drum from 13 kW to 7.5 kW. Also, it will not be necessary to use a metal-intensive and expensive hanging gear to rotate the dryer drum.

### References

1. Baltabaev S.D., Parpiev A.P. Drying of raw cotton. Tashkent, "Oktyuvchi", 1980. 155 p.
2. Uldyakov A.I. Drying of raw cotton. M., Light Industry, 1975. 143 p.
3. Hamburg G.L. Radial supply of heat carrier in a drum dryer. //Cotton industry. Tashkent. 1977 No. 1 pp. 15-16.

4. Parpiev A.P., Sadykov M., Muminov M. Distribution of raw cotton in a drum dryer. //Cotton industry. Tashkent. 1978 No. 5 pp. 25-26.
5. Jamolov R. et al. Development of resource-saving drying technology and its implementation in production. NTO, Paxtasanoatilmiy-markazi (cotton industry scientific center) JSC, Tashkent, 2020, 34 p.
6. Akhmedovna Y. T. To develop students' knowledge, skills and competencies in the organizational and technical aspects of essay //ACADEMICIA: AN INTERNATIONAL MULTIDISCIPLINARY RESEARCH JOURNAL. – 2021. – T. 11. – №. 2. – C. 914-918.
7. Ravshanovna G. N. THE MAIN DIRECTIONS OF DEVELOPING TOLERANCE SKILLS OF PRIMARY SCHOOL PUPILS //European Journal of Research and Reflection in Educational Sciences Vol. – 2020. – T. 8. – №. 3.
8. Xaqnazarova S. Abdullah Sher is a great translator //Journal of Pedagogical Inventions and Practices. – 2021. – T. 3. – C. 44-45.
10. Haqnazarova S. Translation And Literary Influence on The Work of Abdulla Sher //Texas Journal of Multidisciplinary Studies. – 2022. – T. 5. – C. 92-93.
11. Habibiloyevna M. D. The Semantic Analysis of Slang in The Movie “School” //Journal of Pedagogical Inventions and Practices. – 2021. – T. 3. – C. 83-85.