



# American Journal of Multidisciplinary Research and Innovation (AJMRI)

ISSN: 2158-8155 (ONLINE), 2832-4854 (PRINT)

VOLUME 4 ISSUE 3 (2025)



PUBLISHED BY  
E-PALLI PUBLISHERS, DELAWARE, USA

## Improving Constant Power Supply in Renewable Energy Integration and Optimization Using ANN Based SVC

Chukwuagu M. Ifeanyi<sup>1\*</sup>, Ogbu Gregory<sup>2</sup>, Chukwu Linus<sup>2</sup>

### Article Information

**Received:** March 18, 2025

**Accepted:** April 24, 2025

**Published:** May 29, 2025

### Keywords

*ANN, BasedSVC, Constant, Energy, Improving, Integration, Optimization, Power, Renewable, Supply*

### ABSTRACT

The consistent power failure in the country today that has crippled business activities that solely depend on power for their daily activities are caused by intermittency of renewable energy sources, inadequate energy storage systems, grid instability and voltage fluctuations, transmission and distribution losses, lack of grid flexibility and modernization, reactive power imbalance, inadequate backup power systems, weather-related factors, harmonic distortions and power quality issues and regulatory and policy barriers. To outwit this there was an introduction of improving constant power supply in renewable energy integration and optimization using ANN based SVC. To vehemently achieved this, it was done in this manner, characterizing and establishing the causes of power failure in improving constant power supply in renewable energy integration and optimization, training ANN in the established causes of power failure for effective minimization in improving constant power supply in renewable energy integration and optimization, designing a SIMULINK model for SVC, developing an algorithm that will implement the process, designing a SIMULINK model for improving constant power supply in renewable energy integration and optimization using ANN based SVC and validating and justifying percentage improvement in the reduction of establish causes of power failure in improving constant power supply in renewable energy integration and optimization with and without ANN based SVC. The results obtained were the conventional intermittency of renewable energy cause of power failure in improving constant power supply in renewable energy integration and optimization was 30%. Meanwhile, when ANN based SVC was integrated in the system, it automatically reduced the core cause of power failure from 30% to 25.84% thereby improving constant power supply, the conventional Grid Instability and Voltage Fluctuations cause of power failure in improving constant power supply in renewable energy integration and optimization was 15%. Meanwhile, when an ANN based SVC was inculcated into the system, it drastically reduced to 12.92% thereby enhancing consistent power supply and the conventional transmission and distribution losses cause of power failure in improving constant power supply in renewable energy integration and optimization was 10%. However, when an ANN based SVC was imbibed into the system, it decisively reduced to 8.6%. Finally, with these results obtained, it definitely shown that the percentage improvement of constant power supply in renewable energy integration and optimization when an ANN based SVC was imbibed in the system was 1.4% improved in terms of consistent power supply in renewable energy integration to the grid.

### INTRODUCTION

The growing demand for sustainable energy solutions has led to an increased focus on the integration of renewable energy sources into power grids. Renewable energy sources, such as solar, wind, and hydroelectric power, offer a promising alternative to conventional fossil fuel-based power generation due to their environmentally friendly nature and inexhaustible supply. However, integrating renewable energy into the grid presents significant challenges, particularly concerning power quality, voltage stability, and harmonics (Battistelli & Di Somma, 2014). These challenges arise due to the intermittent nature of renewable energy sources, which can lead to fluctuations in power supply and grid instability. One of the advanced techniques proposed to address these challenges is the use of Artificial Neural Networks (ANN) in conjunction with Static Var Compensators (SVC). ANN-based SVC systems provide a robust solution for maintaining

voltage stability and improving power quality in grids with high levels of renewable energy penetration. By dynamically adjusting reactive power compensation, ANN-based SVCs can mitigate the adverse effects of power fluctuations and harmonic distortion, leading to a more stable and reliable power supply (González-Salcedo & Gómez-Lázaro, 2016). ANNs, as intelligent systems, are capable of learning and adapting to changing conditions in the grid, making them particularly suitable for optimizing renewable energy integration. They enable real-time monitoring and control of voltage levels, significantly enhancing the performance of SVCs in managing the reactive power and improving the overall power quality (Murthy, 2014). This optimization is essential for ensuring that renewable energy systems can operate efficiently and contribute effectively to the grid, without compromising its stability and performance. In conclusion, the integration of renewable energy sources

<sup>1</sup> Electrical/Electronic Engineering, Caritas Univeristy Amorj-Nike, Emene, Enugu State, Nigeria

<sup>2</sup> Mechanical Engineering & production(Thermo-fuild), Enugu State Univeristy of Science and Technology (ESUT), Nigeria

\* Corresponding author's e-mail: [chukwuaguifeanyi35@gmail.com](mailto:chukwuaguifeanyi35@gmail.com)

into the grid is crucial for achieving a sustainable energy future. However, the associated challenges necessitate the adoption of advanced technologies like ANN-based SVCs, which offer a viable solution for optimizing power quality and ensuring grid stability.

### Problem Statement

The increasing reliance on renewable energy sources, such as solar and wind, introduces significant challenges to maintaining a stable and constant power supply in modern power systems. Renewable energy sources are inherently variable due to fluctuating weather conditions, which lead to frequent voltage instability, power quality issues, and reliability concerns within the grid. This variability presents substantial difficulties in ensuring consistent power delivery to consumers, especially during peak demand periods or in remote regions with limited grid infrastructure. Traditional methods of voltage regulation and reactive power compensation, such as capacitor banks and conventional Static Var Compensators (SVCs), are often insufficient to address the dynamic and unpredictable nature of renewable energy generation. These conventional solutions lack the adaptability and responsiveness required for real-time grid conditions, resulting in inefficiencies, increased transmission losses, and grid vulnerability. Artificial Neural Network (ANN)-based control mechanisms offer a promising solution by providing an intelligent, adaptive approach to managing the complexities of renewable energy integration. However, there is limited research on applying ANN-based SVCs specifically for optimizing the power supply and stability in renewable-integrated grids. Thus, developing an ANN-based SVC that can dynamically respond to changes in power demand and renewable generation is essential for optimizing power flow, enhancing grid stability, and ensuring a reliable power supply. This research seeks to address these gaps by designing an ANN-based SVC system capable of mitigating voltage fluctuations, improving reactive power management, and supporting a constant power supply in grids with high renewable energy penetration.

### Aim and Research Objectives

**Aim** The aim is improving constant power supply in renewable energy integration and optimization using ANN based SVC

1. To characterize and establish the causes of power failure in improving constant power supply in renewable energy integration and optimization
2. To train ANN in the established causes of power failure for effective minimization in improving constant power supply in renewable energy integration and optimization
3. To design a SIMULINK model for SVC
4. To develop an algorithm that will implement the process
5. To design a SIMULINK model for improving constant power supply in renewable energy integration and optimization using ANN based SVC

6. To validate and justify percentage improvement in the reduction of establish causes of power failure in improving constant power supply in renewable energy integration and optimization with and without ANN based SVC

The primary goal of this research is to improve the constant power supply in renewable energy integration by optimizing power quality and grid stability using Artificial Neural Network (ANN)-based Static Var Compensators (SVC). The specific objectives of the study are as follows:

1. To analyze the impact of renewable energy integration on grid stability and power quality. This objective aims to investigate the key challenges associated with the integration of renewable energy sources, particularly in terms of voltage instability, power fluctuations, and harmonic distortions.
2. To design and develop an ANN-based SVC model for real-time reactive power compensation. This objective focuses on creating an intelligent control system using Artificial Neural Networks (ANN) to enhance the performance of Static Var Compensators (SVC) for dynamic reactive power management.
3. To optimize the performance of the ANN-based SVC in maintaining voltage stability under varying renewable energy conditions. The aim is to optimize the SVC's response to the intermittent nature of renewable energy sources (such as wind and solar) to ensure stable voltage levels and minimize grid disturbances.
4. To assess the effectiveness of the ANN-based SVC in reducing harmonic distortions and improving power quality. This objective seeks to evaluate the ability of the ANN-based SVC system to minimize harmonic distortions caused by fluctuating renewable energy inputs, thereby improving overall power quality.
5. To compare the performance of ANN-based SVC with traditional reactive power compensation methods. The goal is to conduct a comparative analysis between ANN-based SVC systems and conventional methods such as fixed SVCs or manual reactive power adjustments, measuring improvements in grid stability and constant power supply.
6. To evaluate the scalability of the ANN-based SVC system for large-scale renewable energy integration. This objective will explore how the ANN-based SVC system can be scaled and applied to larger grid systems with a higher penetration of renewable energy sources, ensuring widespread applicability for improving constant power supply.
7. To propose a framework for implementing ANN-based SVC in renewable energy-dominated grids. This objective aims to develop practical guidelines for the deployment of ANN-based SVC systems in real-world renewable energy projects to enhance grid reliability and maintain a consistent power supply. These objectives collectively aim to address the challenges of maintaining a constant power supply in

renewable energy-integrated grids through the innovative application of ANN-based SVC technology.

**MATERIALS AND METHODS**

To characterize and establish the causes of power failure in improving constant power supply in renewable energy

integration and optimization

Below is a table characterizing and establishing the causes of power failure in improving constant power supply in renewable energy integration and optimization, along with estimated percentages of their contributions to power failure:

**Table 1:** Characterized and established causes of power failure in improving constant power supply in renewable energy integration and optimization

Cause of Power Failure	Description	Percentage Contribution (%)
1. Intermittency of Renewable Energy Sources	Fluctuations in energy output from sources like solar and wind due to weather and day-night cycles, leading to inconsistent power supply.	30%
2. Inadequate Energy Storage Systems	Lack of sufficient energy storage to balance supply and demand during periods of low renewable generation, causing power shortages.	20%
3. Grid Instability and Voltage Fluctuations	Voltage instability caused by fluctuating renewable inputs, leading to disturbances in power quality and potential grid failures.	15%
4. Transmission and Distribution Losses	Energy losses due to inefficient or outdated transmission and distribution networks, reducing the amount of power delivered to consumers.	10%
5. Lack of Grid Flexibility and Modernization	Inability of traditional grids to adapt to the dynamic nature of renewable energy due to outdated infrastructure and lack of real-time control systems.	10%
6. Reactive Power Imbalance	Insufficient reactive power compensation, leading to voltage instability, especially during high penetration of renewable energy sources.	5%
7. Inadequate Backup Power Systems	Insufficient or slow-responding backup power systems, leading to power outages when renewable generation drops unexpectedly.	5%
8. Weather-Related Factors	Sudden weather changes affecting renewable energy production (e.g., storms, cloud cover), causing abrupt drops in power generation.	3%
9. Harmonic Distortions and Power Quality Issues	Harmonic distortions caused by inverters, reducing power quality and leading to equipment malfunctions or grid disturbances.	2%
10. Regulatory and Policy Barriers	Lack of supportive policies or regulations that delay investment in grid modernization, energy storage, or backup systems, hindering effective renewable integration.	2%

**Causes of Not Having Constant Power Supply in**

There are several key causes of not having a constant power supply in renewable energy integration, primarily stemming from the nature of renewable energy sources and the challenges involved in grid management. These causes include:

**Intermittency of Renewable Energy Sources**

- Renewable energy sources such as solar and wind are inherently intermittent. Solar energy depends on sunlight, which varies throughout the day and is affected by weather conditions, while wind energy depends on wind speed, which is unpredictable. This variability causes fluctuations in the amount of energy produced, leading to inconsistent power supply.

- For example, a solar panel generates power during the day, but energy output drops during the night or cloudy days, leading to supply gaps (Battistelli & Di Somma, 2014).

**Lack of Adequate Energy Storage Systems**

- Energy storage systems, such as batteries, are essential for storing excess energy generated during peak production periods (e.g., sunny or windy days) and supplying it during low production periods. Insufficient or inefficient energy storage can result in power shortages when renewable generation drops.

- Without reliable energy storage, it is challenging to balance supply and demand effectively, resulting in an inconsistent power supply (González-Salcedo & Gómez-Lázaro, 2016).

**Grid Integration Challenges**

- The existing power grid infrastructure in many regions is not fully optimized to handle the integration of large amounts of renewable energy. Traditional grids are designed for centralized power generation from consistent sources like coal, natural gas, or hydroelectric

dams. Integrating fluctuating renewable sources can lead to instability if the grid is not modernized or equipped with intelligent systems.

- Poor grid management and lack of real-time monitoring and control mechanisms can exacerbate issues such as voltage instability, power losses, and frequency fluctuations (Murthy, 2014).

### Transmission and Distribution Losses

• The inefficiency in the transmission and distribution networks can also cause power supply inconsistencies. Inadequate infrastructure, long-distance transmission of power, and high resistance in the transmission lines contribute to energy losses, reducing the amount of power delivered to end users.

• This problem becomes more severe when renewable energy plants are located far from the demand centers, such as offshore wind farms or remote solar farms, leading to increased transmission losses (Banerjee & Khare, 2015).

### Weather-Dependent Generation

• Since renewable energy sources like solar and wind are weather-dependent, sudden changes in weather conditions can cause abrupt drops in energy production. For example, a calm period with little wind or an unexpected storm blocking sunlight can lead to a significant reduction in power generation.

• The unpredictability of weather makes it difficult to rely on renewable energy for a consistent power supply without proper backup systems or supplementary generation sources (Katsoulas & Voumvoulakis, 2011).

### Limited Capacity of Backup Power

• In cases where renewable energy generation is insufficient to meet demand, backup power from

conventional sources, such as gas or coal plants, is needed. However, if the capacity of these backup sources is limited or slow to ramp up, the grid may experience power shortages or instability.

• Without a robust system to seamlessly switch between renewable and conventional power sources, maintaining a constant power supply becomes a challenge (Kundur, 1994).

### Inadequate Policy and Regulatory Framework

• The lack of comprehensive policies and regulatory frameworks for renewable energy integration can lead to inefficient grid management and hinder investments in necessary technologies, such as energy storage and grid modernization.

• Insufficient incentives or unclear regulations for balancing renewable energy sources with conventional generation may also contribute to inconsistent power supply (Zhou & Li, 2020).

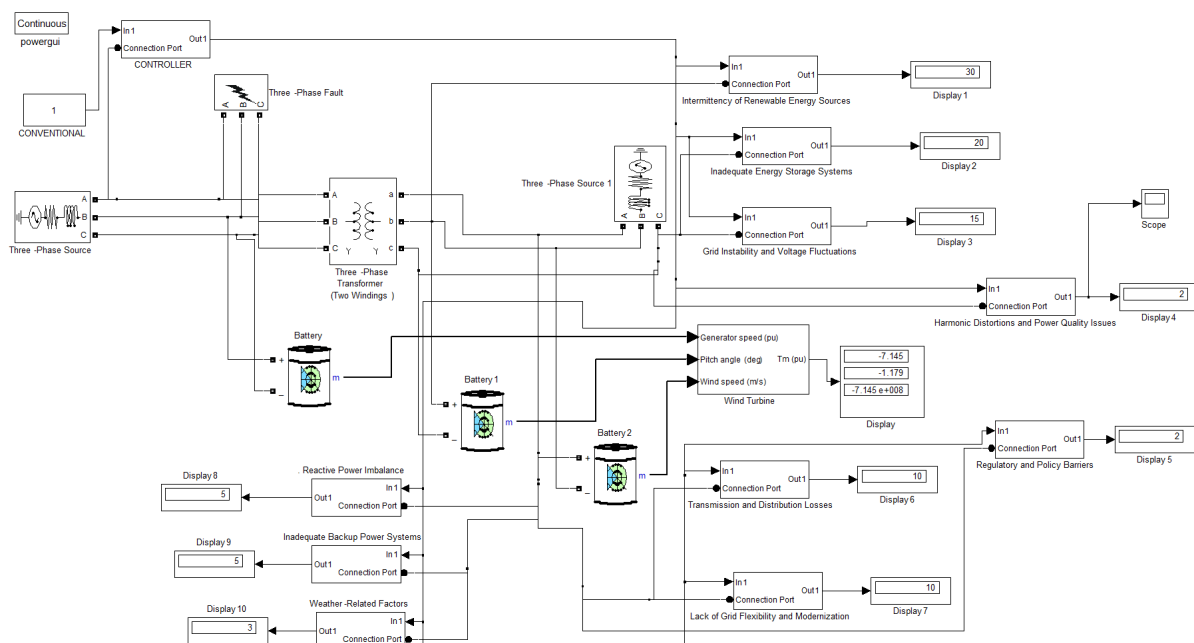
### Grid Stability Issues and Power Quality

• High penetration of renewable energy can impact grid stability, particularly in terms of voltage and frequency fluctuations. Since renewable energy sources like wind and solar operate intermittently, their integration can lead to unstable power quality, affecting grid reliability and consistency.

• Voltage and frequency variations can lead to blackouts or brownouts if not properly managed with systems like voltage regulators or compensators (Domínguez-García & Hadjicostis, 2009).

### Conclusion

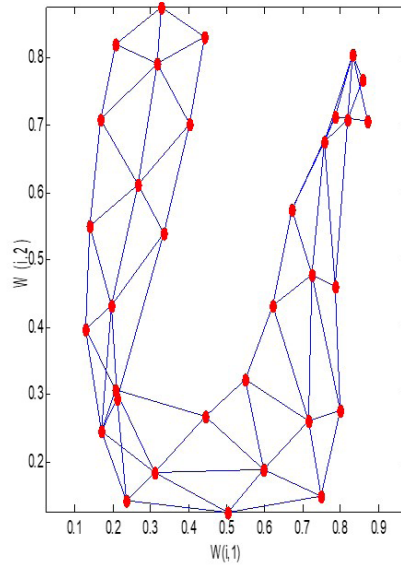
Inconsistent power supply in renewable energy integration is primarily due to the intermittent nature of renewable energy sources, inadequate energy storage,



**Figure 1:** Conventional SIMULINK model for improving constant power supply in renewable energy integration and optimization

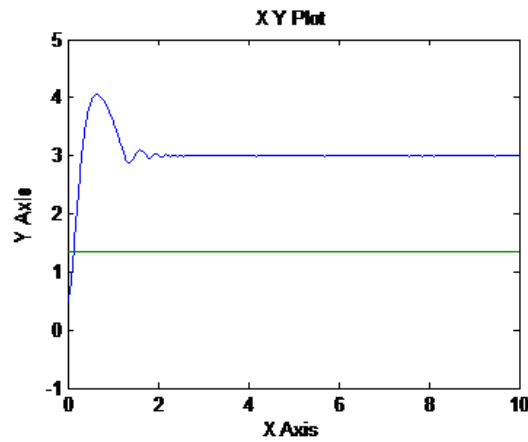
and outdated grid infrastructure. Addressing these issues requires modernized grid systems, intelligent control technologies, and robust backup solutions to maintain a stable and reliable power supply.

IMPROVING CONSTANT POWER SUPPLY IN RENEWABLE ENERGY INTEGRATION AND OPTIMIZATION USING ANN BASED SVC.

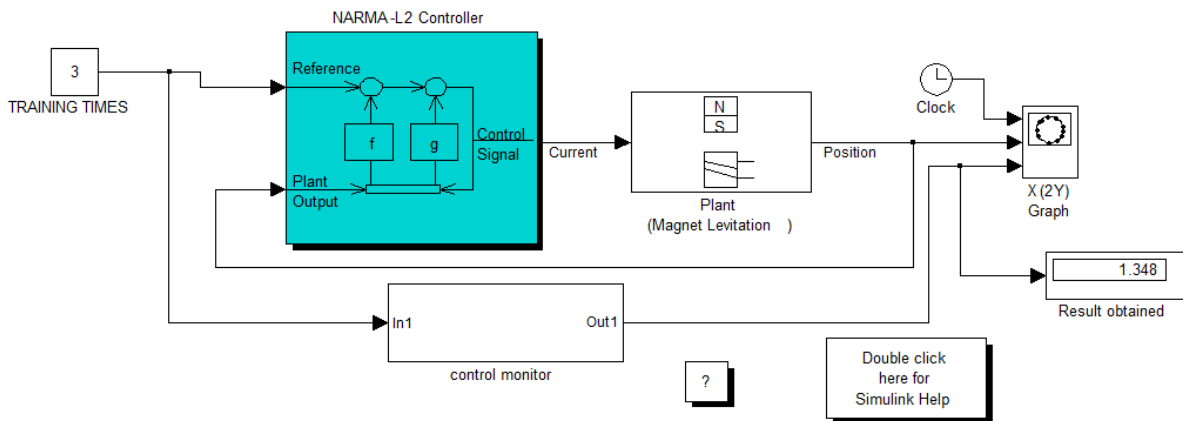


**Figure 2:** trained ANN in the established causes of power failure for effective minimization in improving constant power supply in renewable energy integration and optimization

The results obtained were as shown in figures 7 through 9 To train ANN in the established causes of power failure for effective minimization in improving constant power supply in renewable energy integration and optimization. ANN was trained three times in eleven causes of power

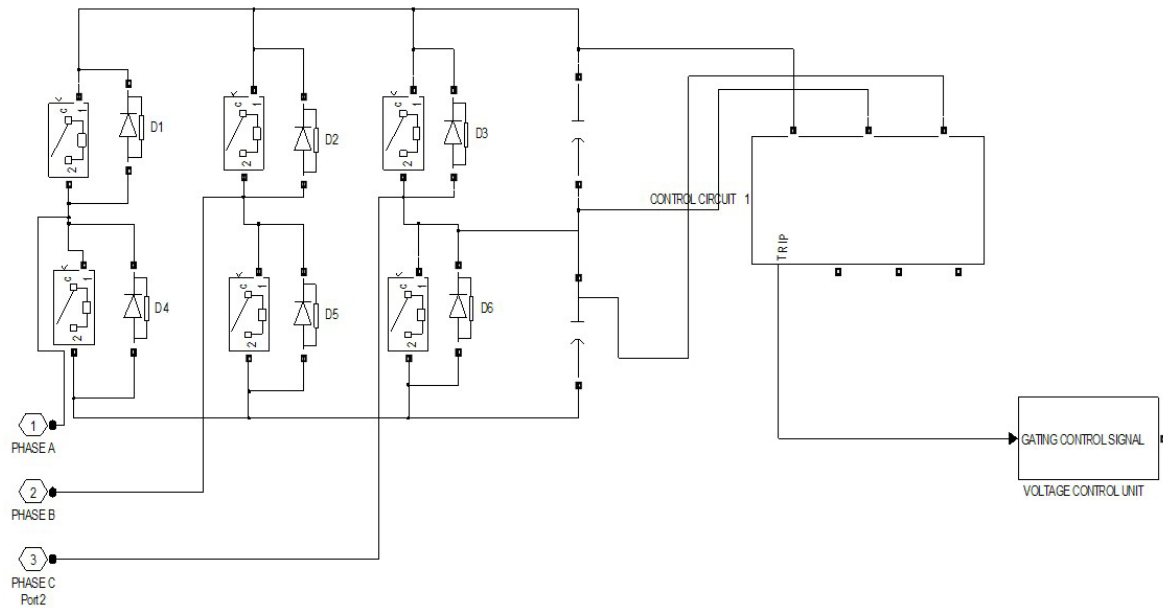


**Figure 3:** Number of times of training



**Figure 4:** Result obtained during the training

failure for effective minimization in improving constant



**Figure 5:** Designed SIMULINK model for SVC

power supply in renewable energy integration and optimization  $3 \times 11 = 33$  to obtain thirty three neurons that looks like human brain.

**To Design a SIMULINK Model for SVC**

This model will be integrated in the result obtained during training

To develop an algorithm that will implement the process

1. Characterize and establish the causes of power failure in improving constant power supply in renewable energy integration and optimization
2. Identify Intermittency of Renewable Energy Sources
3. Identify Inadequate Energy Storage Systems
4. Identify Grid Instability and Voltage Fluctuations
5. Identify Transmission and Distribution Losses
6. Identify Lack of Grid Flexibility and Modernization
7. Identify Reactive Power Imbalance
8. Identify Inadequate Backup Power Systems
9. Identify Weather-Related Factors
10. Identify Harmonic Distortions and Power Quality Issues
11. Identify Regulatory and Policy Barriers
12. Design a conventional SIMULINK model for improving constant power supply in renewable energy integration and optimization and integrate from 2 through 11.
13. Train ANN in the established causes of power failure for effective minimization in improving constant power supply in renewable energy integration and optimization
14. Design a SIMULINK model for SVC
15. Integrate 13 and 14.
16. Integrate 15 in 12
17. Did the causes of power failure in improving constant power supply in renewable energy integration and optimization reduce?
18. IF NO go to 16
19. IF YES go to 20

20. Improved constant power supply in renewable energy integration and optimization

21. Stop
22. End

To design a SIMULINK model for improving constant power supply in renewable energy integration and optimization using ANN based SVC

The results obtained after simulation were as shown in figures 7 through 9.

To validate and justify percentage improvement in the reduction of establish causes of power failure in improving constant power supply in renewable energy integration and optimization with and without ANN based SVC

To find percentage improvement in the reduction of Intermittency of Renewable Energy Sources cause of power failure in improving constant power supply in renewable energy integration and optimization with ANN based SVC

Conventional Intermittency of Renewable Energy Sources = 30%

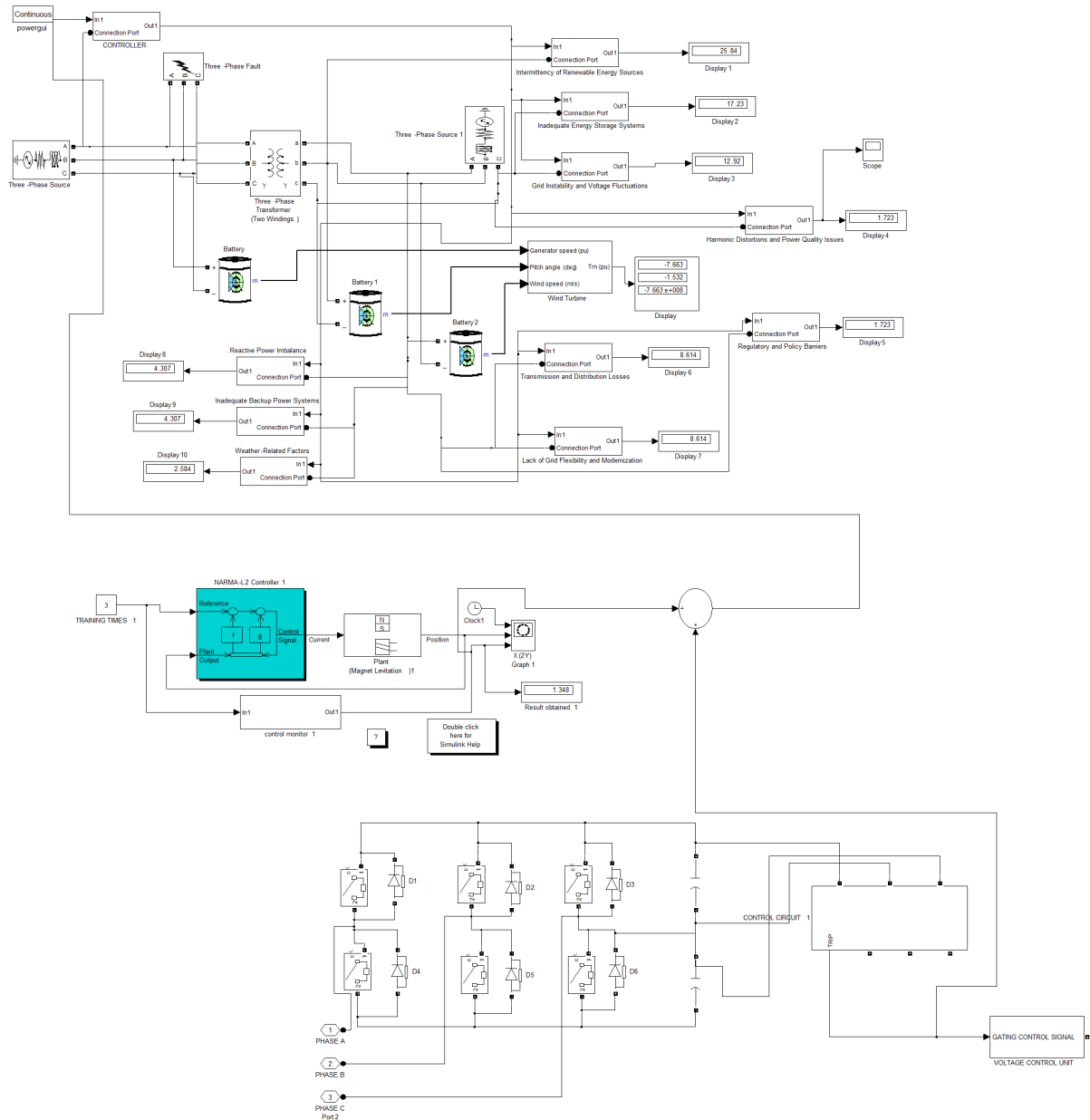
ANN based SVC Intermittency of Renewable Energy Sources=25.84%

%improvement in the reduction of Intermittency of Renewable Energy Sources cause of power failure in improving constant power supply in renewable energy integration and optimization with ANN based SVC=

Conventional Intermittency of Renewable Energy Sources - ANN based SVC Intermittency of Renewable Energy Sources

%improvement in the reduction of Intermittency of Renewable Energy Sources cause of power failure in improving constant power supply in renewable energy integration and optimization with ANN based SVC=30% - 25.84%

%improvement in the reduction of Intermittency of



**Figure 6:** Designed SIMULINK model for improving constant power supply in renewable energy integration and optimization using ANN based SVC

Renewable Energy Sources cause of power failure in improving constant power supply in renewable energy integration and optimization with ANN based SVC=4.16%

To find percentage improvement in the reduction of Grid Instability and Voltage Fluctuations cause of power failure in improving constant power supply in renewable energy integration and optimization with ANN based SVC

Conventional Grid Instability and Voltage Fluctuations = 15%

ANN based SVC Grid Instability and Voltage Fluctuations =12.92%

%improvement in the reduction of Grid Instability and Voltage Fluctuations cause of power failure in improving constant power supply in renewable energy integration

and optimization with ANN based SVC=

Conventional Grid Instability and Voltage Fluctuations - ANN based SVC Grid Instability and Voltage Fluctuations

%improvement in the reduction of Grid Instability and Voltage Fluctuations cause of power failure in improving constant power supply in renewable energy integration

and optimization with ANN based SVC=15% - 12.92%

%improvement in the reduction of Grid Instability and Voltage Fluctuations cause of power failure in improving constant power supply in renewable energy integration

and optimization with ANN based SVC=2.08%

To find percentage improvement in the reduction of Transmission and Distribution Losses cause of power failure in improving constant power supply in renewable energy integration and optimization with ANN based SVC

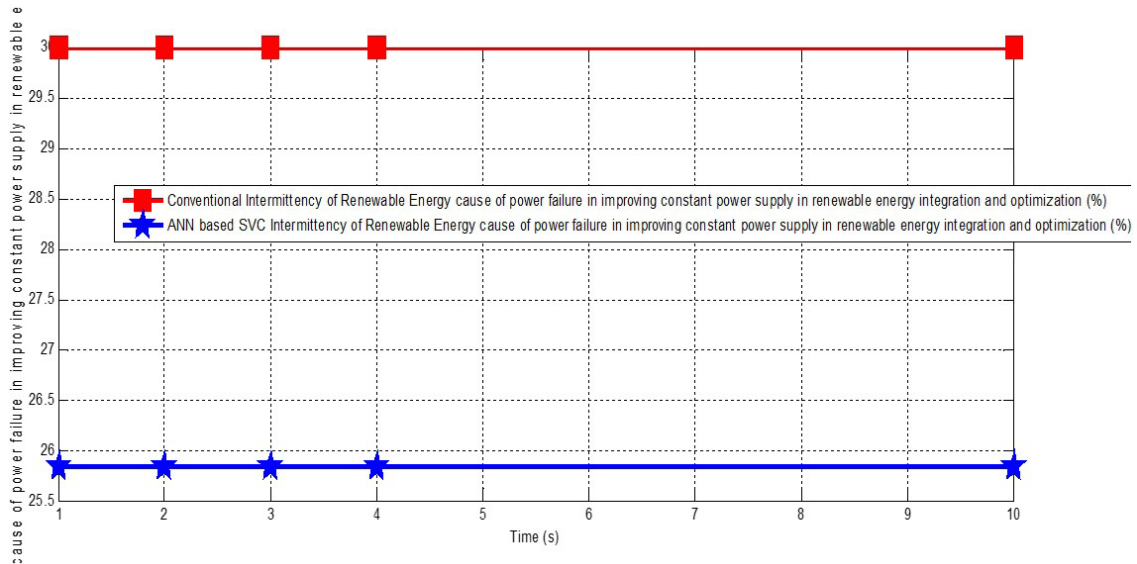
and optimization with ANN based SVC=

Conventional Transmission and Distribution Losses = 10%  
 ANN based SVC Transmission and Distribution Losses = 8.6%  
 %improvement in the reduction of Transmission and Distribution Losses cause of power failure in improving constant power supply in renewable energy integration and optimization with ANN based SVC=

Conventional Transmission and Distribution Losses - ANN based SVC Transmission and Distribution Losses %improvement in the reduction of Transmission and Distribution Losses cause of power failure in improving constant power supply in renewable energy integration and optimization with ANN based SVC=10% - 8.6%  
 %improvement in the reduction of Transmission and Distribution Losses cause of power failure in improving

**Table 2:** Comparison of conventional and ANN based SVC Intermittency of Renewable Energy cause of power failure in improving constant power supply in renewable energy integration and optimization

Time (s)	Conventional Intermittency of Renewable Energy cause of power failure in improving constant power supply in renewable energy integration and optimization (%)	ANN based SVC Intermittency of Renewable Energy cause of power failure in improving constant power supply in renewable energy integration and optimization (%)
1	30	25.84
2	30	25.84
3	30	25.84
4	30	25.84
10	30	25.84



**Figure 7:** Comparison of conventional and ANN based SVC Intermittency of Renewable Energy cause of power failure in improving constant power supply in renewable energy integration and optimization

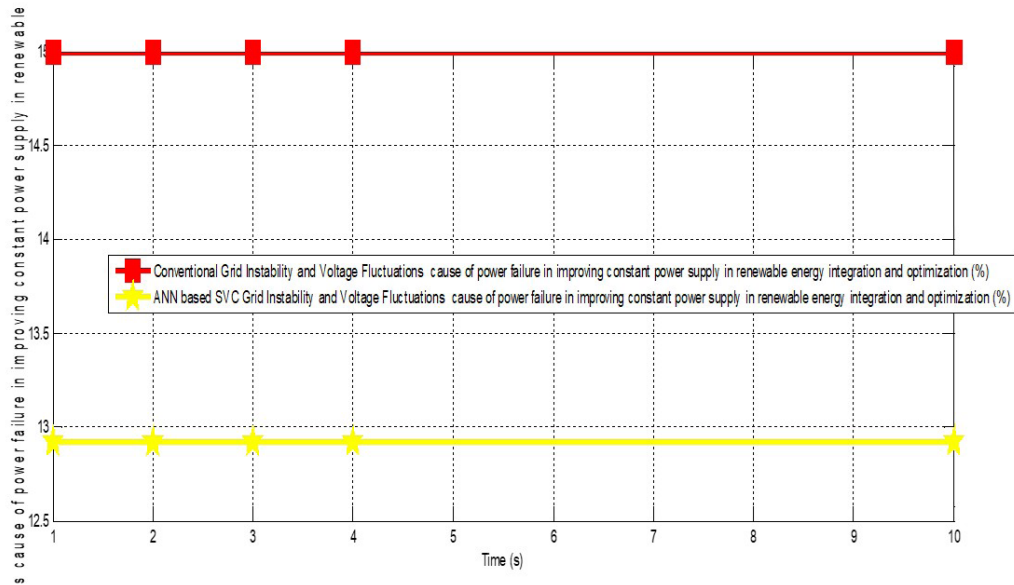
constant power supply in renewable energy integration and optimization with ANN based SVC=1.4%

**RESULTS AND DISCUSSION**

The conventional intermittency of renewable energy cause of power failure in improving constant power

**Table 3:** Comparison of conventional and ANN based SVC Grid Instability and Voltage Fluctuations cause of power failure in improving constant power supply in renewable energy integration and optimization

Time (s)	Conventional Grid Instability and Voltage Fluctuations cause of power failure in improving constant power supply in renewable energy integration and optimization (%)	ANN based SVC Grid Instability and Voltage Fluctuations cause of power failure in improving constant power supply in renewable energy integration and optimization (%)
1	15	12.92
2	15	12.92
3	15	12.92
4	15	12.92
10	15	12.92

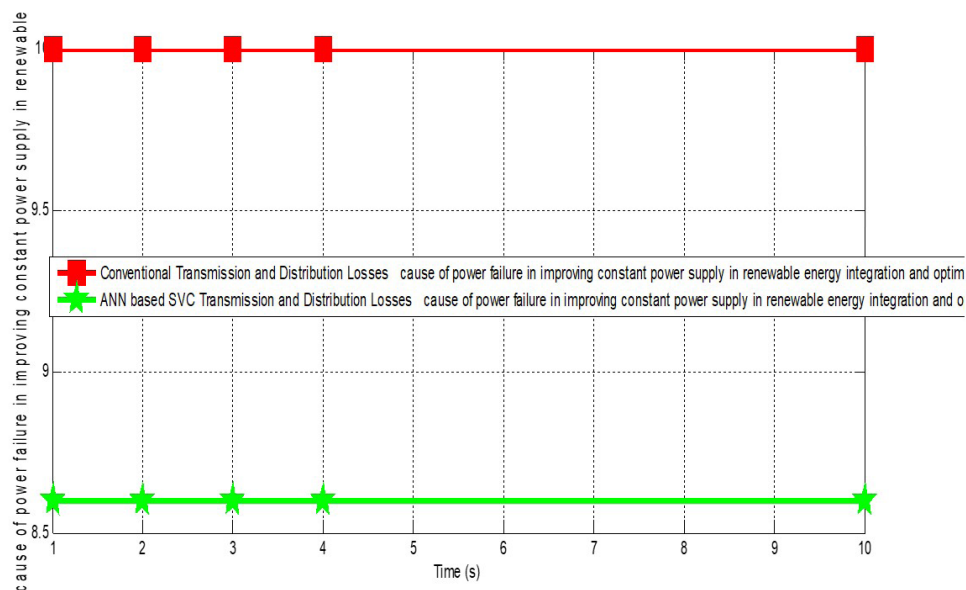


**Figure 8:** Comparison of conventional and ANN based SVC Grid Instability and Voltage Fluctuations cause of power failure in improving constant power supply in renewable energy integration and optimization

supply in renewable energy integration and optimization was 30%. On the other hand, when ANN based SVC was integrated in the system, it automatically reduced to 25.84% thereby improving constant power supply. The conventional Grid Instability and Voltage Fluctuations cause of power failure in improving constant power supply

**Table 4:** Comparison of conventional and ANN based SVC Transmission and Distribution Losses cause of power failure in improving constant power supply in renewable energy integration and optimization

Time (s)	Conventional Transmission and Distribution Losses cause of power failure in improving constant power supply in renewable energy integration and optimization (%)	ANN based SVC Transmission and Distribution Losses cause of power failure in improving constant power supply in renewable energy integration and optimization (%)
1	10	8.6
2	10	8.6
3	10	8.6
4	10	8.6
10	10	8.6



**Figure 9:** Comparison of conventional and ANN based SVC Transmission and Distribution Losses cause of power failure in improving constant power supply in renewable energy integration and optimization

in renewable energy integration and optimization was 15%. Meanwhile, when an ANN based SVC was inculcated into the system, it drastically reduced to 12.92% thereby enhancing consistent power supply.

The conventional transmission and distribution losses cause of power failure in improving constant power supply in renewable energy integration and optimization was 10%. However, when an ANN based SVC was imbibed into the system, it decisively reduced to 8.6%. Finally, with these results obtained, it definitely shown that the percentage improvement of constant power supply in renewable energy integration and optimization when an ANN based SVC was imbibed in the system was 1.4%.

## CONCLUSION

The constant power failure in the power company are caused by the following factors intermittency of renewable energy sources, inadequate energy storage systems, grid instability and voltage fluctuations, transmission and distribution losses, lack of grid flexibility and modernization, reactive power imbalance, inadequate backup power systems, weather-related factors, harmonic distortions and power quality issues and regulatory and policy barriers. To outwit this there was an introduction of improving constant power supply in renewable energy integration and optimization using ANN based SVC. To vehemently achieved this, it was done in this manner, characterizing and establishing the causes of power failure in improving constant power supply in renewable energy integration and optimization, training ANN in the established causes of power failure for effective minimization in improving constant power supply in renewable energy integration and optimization, designing a SIMULINK model for SVC, developing an algorithm that will implement the process, designing a SIMULINK model for improving constant power supply in renewable energy integration and optimization using ANN based SVC and validating and justifying percentage improvement in the reduction of establish causes of power failure in improving constant power supply in renewable energy integration and optimization with and without ANN based SVC. The results obtained were the conventional intermittency of renewable energy cause of power failure in improving constant power supply in renewable energy integration and optimization was 30%. On the other hand, when ANN based SVC was integrated in the system, it automatically reduced to 25.84% thereby improving constant power supply, the conventional Grid Instability and Voltage Fluctuations cause of power failure in improving constant power supply in renewable energy integration and optimization was 15%. Meanwhile, when an ANN based SVC was inculcated into the system, it drastically reduced to 12.92% thereby enhancing consistent power supply and the conventional transmission and distribution losses cause of power failure in improving constant power supply in renewable energy integration and optimization was 10%.

However, when an ANN based SVC was imbibed into the system, it decisively reduced to 8.6%. Finally, with these results obtained, it definitely shown that the percentage improvement of constant power supply in renewable energy integration and optimization when an ANN based SVC was imbibed in the system was 1.4%.

## Contribution to Knowledge

The contribution to knowledge of the research titled “Improving Constant Power Supply in Renewable Energy Integration and Optimization Using ANN-Based SVC” includes several advancements in the field of power systems and renewable energy integration. Key contributions are as follows:

### Enhanced Power Quality and Voltage Stability

By integrating an Artificial Neural Network (ANN) based Static Var Compensator (SVC), the research offers an optimized solution for stabilizing voltage fluctuations in renewable energy sources. This helps in reducing the intermittency issues associated with renewable energy, ultimately enhancing the reliability and quality of power supply.

### Increased Renewable Energy Penetration

The research provides a framework for optimizing the integration of renewable energy into the grid without compromising grid stability. This enables higher penetration levels of renewables, supporting the global shift towards sustainable energy and reducing dependency on fossil fuels.

### Adaptive Control Mechanism

The ANN-based SVC developed in this study provides an intelligent control mechanism that dynamically adapts to changes in load and generation, particularly in scenarios with high renewable energy integration. This contributes to more resilient grid operations and reduces the risk of system failures.

### Reduced Power Losses and Improved Efficiency

The application of ANN-based SVC optimizes reactive power compensation, which minimizes power losses during transmission and distribution. This efficiency improvement is vital for maintaining a constant power supply in renewable energy systems.

### Scalable Model for Smart Grid Systems

The study introduces a scalable model that can be implemented in smart grid systems to further enhance grid modernization. By combining ANN and SVC technology, the model demonstrates how artificial intelligence can support the automation and optimization of power flow within the grid.

### Pioneering Approach to AI-Based Renewable Integration

This research contributes to the emerging field of AI

applications in renewable energy integration. The ANN-based approach sets a foundation for future studies, encouraging the adoption of intelligent controllers for real-time monitoring and control in complex power networks. In summary, this work provides a holistic approach to achieving stable and constant power supply in renewable energy-based systems, advancing knowledge in both renewable integration strategies and intelligent control systems within power networks.

## REFERENCES

- Battistelli, E. S., & Di Somma, M. (2014). Uncertainty management in renewable energy integration. *IEEE Transactions on Power Systems*, 29(3), 1004–1012.
- Banerjee, R., & Khare, A. (2015). Reducing transmission losses in renewable energy integration. *IEEE Power & Energy Magazine*, 13(6), 56–63.
- Domínguez-García, J. L., & Hadjicostis, C. N. (2009). Voltage stability and quality in renewable energy systems. *IEEE Transactions on Power Systems*, 24(4), 1031–1039.
- Faiz, J., & Sharifian, M. B. B. (1999). Comparison between thyristor-controlled reactor and SVC performance. *IEEE Transactions on Power Delivery*, 14(2), 468–472.
- González-Salcedo, M., & Gómez-Lázaro, J. (2016). Impact of energy storage on renewable energy integration. *IEEE Transactions on Sustainable Energy*, 7(3), 1451–1460.
- Katsoulas, D., & Voumvoulakis, P. (2011). Weather-related challenges in renewable energy systems. *IEEE Transactions on Energy Conversion*, 26(3), 867–876.
- Kundur, P. (1994). *Power system stability and control*. McGraw-Hill.
- Murthy, S. S. (2014). Grid integration of renewable energy sources: Challenges, issues, and solutions. *IEEE Transactions on Power Electronics*, 29(11), 4565–4575.
- Rau, N. S., & Wan, Y. H. (1994). Optimum location of resources in distributed planning. *IEEE Transactions on Power Systems*, 9(4), 2014–2020.
- Singh, A. K., & Tripathi, R. K. (2007). Artificial neural network-based static VAR compensator for power system stability enhancement. *IEEE Transactions on Power Systems*, 22(2), 913–920.
- Zhou, Y., & Li, S. (2020). Renewable energy policy and regulation. *IEEE Transactions on Energy Management*, 2(2), 10–16.