

## A GREENER FUTURE: ENERGY-SAVING CONTROL'S ROLE IN MECHANICAL AND ELECTRONIC ENGINEERING ADVANCEMENTS

**Zhu, Yi-Qiang**

College of Mechanical and Transportation, Southwest Forestry University, Kunming, 650000, Yunnan, China

**Abstract:** Energy-saving control systems play a pivotal role in the realm of mechanical and electronic engineering, facilitating the efficient management of mechanical and electrical equipment while curbing energy wastage. This article delves into the energy-saving control of asynchronous motors for vehicles, with the primary objective of reducing energy consumption and enhancing motor efficiency. The study also aims to extend the electric vehicle's operational range, contributing significantly to the advancement of Wang Mechanical and Electronic Engineering. By integrating energy-saving control systems into mechanical and electrical engineering, this research endeavors to amplify energy conservation without compromising the equipment's regular functioning, optimizing energy utilization and yielding superior performance. This not only augments the machinery and electronics sector but also fosters sustainable development across economic, energy, and environmental domains.

**Keywords:** Energy-saving control systems, Asynchronous motors, Electric vehicles, Mechanical and electrical engineering, Sustainable development

### 1. Introduction

The use of energy-saving control systems in mechanical and electronic engineering can achieve efficient energy-saving control of mechanical and electrical equipment, while ensuring the normal operation of mechanical equipment and minimizing energy losses as much as possible. This is of great significance for the energy-saving development of Wang Mechanical and Electronic Engineering. In view of this, this article takes the energy-saving controller of asynchronous motors for vehicles as the research object, with the goal of reducing motor energy consumption and improving motor efficiency, and focuses on extending the range of electric vehicles. This study can provide reference for the application and development of mechanical, electrical, and electrical fields. Applying energy-saving control systems to mechanical and electrical engineering can significantly improve the energy-saving effect of the machine while ensuring its normal operation, maximizing the energy utilization rate of the machine, and thus achieving the best working results. This is not only conducive to the development of machinery and electronics, but also to the sustainable development of today's economy, energy, and environment. Energy saving control technology is currently one of the hot topics in research, among which Huang Huacheng explored IoT control technology based on IoT campus energy-saving and consumption reducing street light systems [1]. Ashryatov, A. A., V. G. Kulikov considered the advantages of electronic starting devices in street light control systems in order to create energy-saving control systems. They analyzed the current status of street light lighting methods, identified their shortcomings and solutions, and developed energy-saving control methods for street light lighting devices [2]. Chang Jau-Yang has designed a multi hop based energy-saving control scheme

to handle the sleep process of sensor devices. Based on the multi hop routing structure, self-adaptive decisions are made to select the type of power saving level, which brings reasonable energy consumption and appropriate packet delay time to sensor devices [3]. Ding Renkai Ruo Chen Wang has designed an energy-saving control strategy and its corresponding implementation structure to reconcile the contradiction between dynamic performance and energy consumption [4]. However, due to insufficient data sources, the above research is only in the theoretical stage and lacks practical significance.

## 2. Design of Energy-Saving Controller for Asynchronous Motors

This article focuses on the hardware design of the energy-saving controller for asynchronous motors used in electric vehicles. Based on the overall design scheme of the energy-saving controller hardware, the various components of the energy-saving controller hardware system were selected and analyzed in detail. Using the relevant design software - Aluminum Designer 16, the circuit schematic diagram and circuit board were designed and drawn [5-6].

### 2.1. Hardware Design of Energy-Saving Controller

The energy-saving controller for automotive asynchronous motors designed in this article mainly includes DSP control circuit, IPM main circuit, signal detection circuit, etc. [7]. This article is based on the design of hardware circuits that achieve different functions, and organizes and arranges them, including the following contents: circuit schematic diagram and overall layout plan. The overall hardware structure of the energy-saving controller is shown in Figure 1.

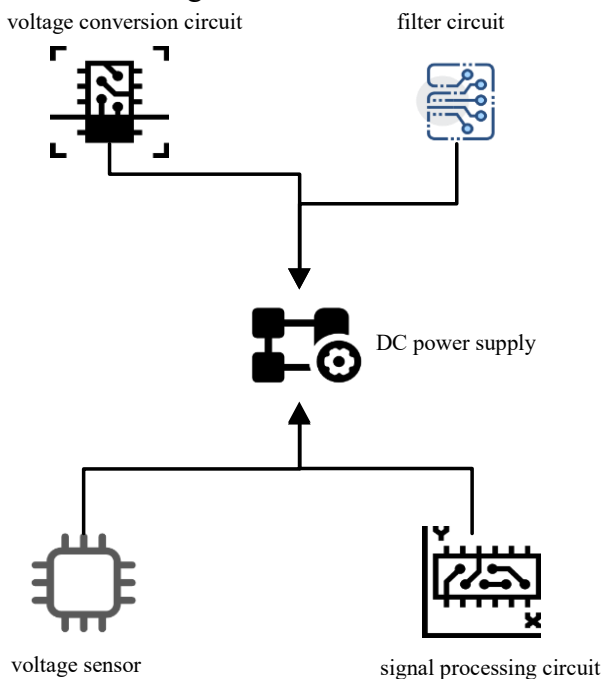

Figure 1. Overall structure of the energy-saving controller hardware system

## **2.2. Control Circuit Design of Digital Signal Processing Technology**

The energy-saving control technology introduced in this article is mainly an energy-saving control circuit designed based on the DSP chip TM320F28335. The design of the DSP control circuit is the most important part of the entire hardware system design [8-9]. In this section, the basic features of the F28335 main control chip are first introduced. Then, based on the current mature technological achievements, the corresponding design of the DSP control circuit was carried out, and a DSP control circuit that meets the requirements of the work in this article was ultimately developed.

The digital signal processing technology (DSP) utilizes an event triggering module in enhanced pulse width modulation (ePWM) to generate the interrupt signal or transform signal; By using a driver isolation circuit, a Pulse Width Modulation (PWM) signal is transmitted to an Intelligent Power Module (IPM) for switching action; After performing voltage transformation, filtering, and limiting operations, the sampled signal can be transmitted to the DSP's transformation module if it meets the conditions for input analog signals. The fault protection signal of IPM is output to the DSP main control chip, which effectively protects the inverter circuit [10].

## **2.3. Software System Design of Energy-Saving Controller**

This article introduces a new type of energy-saving controller for asynchronous motors and provides a detailed analysis of it. On the hardware platform of the energy-saving controller designed in this article, the software system design of the asynchronous motor energy-saving controller was completed using dedicated integrated development software of DSP chips, and subsequent debugging and improvement work was carried out [11-12].

### **(1) System main program design**

In this article, a detailed analysis and research have been conducted on the control technology of induction motors. In practical applications, due to its own characteristics and characteristics, a detailed analysis has been conducted and corresponding solutions have been proposed. Therefore, in order to ensure that the energy-saving controller achieves the expected functions, it is necessary to accurately digitize various input signals, efficiently process signals, and output control signals in real-time. There are a large number of self-protection lines in energy-saving control systems. How to quickly and stably process fault signals at the software level is also the key to ensuring the safe and stable operation of energy-saving control systems. In this scheme, programming is carried out in a modular manner, ensuring that the overall code structure of the system is clear, concise, and easy to understand, while also facilitating later maintenance and updates [13]. The software system design scheme in this article consists of two parts: the main program and the interrupt submodule. The main program completes the input instructions of the upper computer after initialization, and the interrupt submodule includes modules such as AD conversion, coordinate transformation, and energy-saving control. The A/D acquisition circuit collects the signal output by the Hall sensor and converts it into a digital quantity; The QEP testing module mainly includes: calculation of the position and speed of the rotor flux linkage; The coordinate conversion module completes karat conversion, parker conversion, and parker inverse conversion; The energy-saving control module adjusts the MT axis current based on theory and analysis, and the motor load condition. The flowchart of the main program is shown in Figure 2.

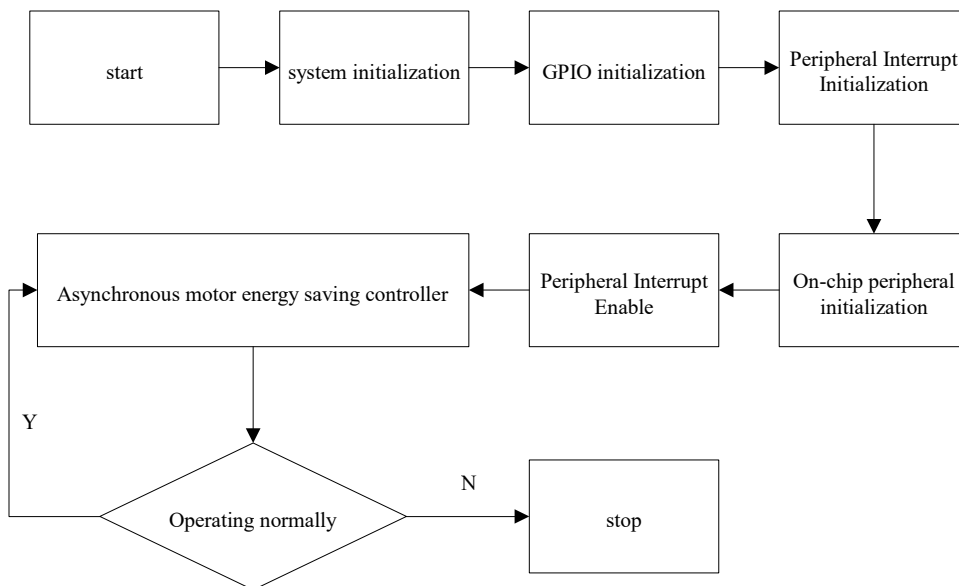

Figure 2. Main program flowchart

(2) Energy saving control module

In the software design of energy-saving controllers, the energy-saving control module is the most important and crucial part [14-15]. Due to the difficulty in directly measuring the load of an induction motor under normal operating conditions, this article uses stator current as an intermediary to indirectly obtain the magnitude of the induction motor load. Based on the above theoretical analysis, it can be concluded that when the motor is operated under different load conditions, there would be an optimal voltage value corresponding to it. The energy-saving control module can control the supply voltage value through the measured stator current, thereby reasonably reducing the magnetic flux level, reducing motor losses, and improving the working efficiency of asynchronous motors. When the load changes, the system comprehensively judges whether energy-saving regulation is necessary under the current load state of the asynchronous motor based on the current  $I$ , current current, and threshold detected in the previous round [16-17]. To avoid oscillation of the optimization search operation around the optimal value during the energy-saving regulation process, which may cause unstable power supply voltage and cause excessive vibration and noise. So, when the amplitude of current change exceeds the pre-set threshold, the induction motor would enter the energy-saving regulation mode. The flowchart of the energy-saving control module is shown in Figure 3:

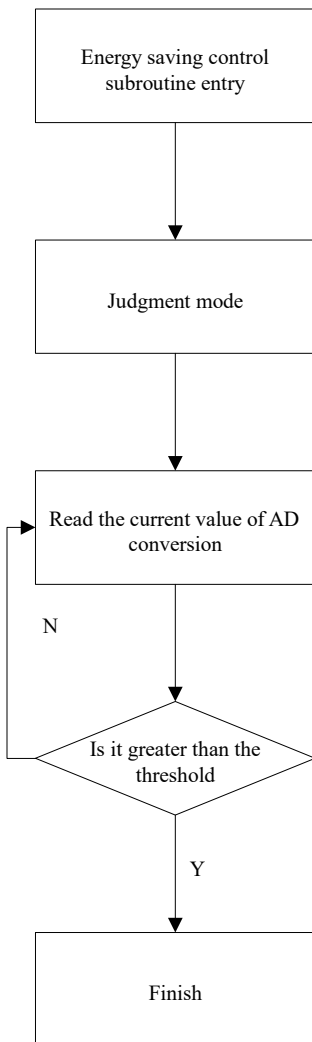

Figure 3. Energy saving control subroutine flowchart

#### 2.4. Implementation of Frequency Converters and Their Energy-Saving Principles

In this energy-saving control system, the main function of the frequency converter is to regulate the induced draft fan, water supply system, and blower. According to the relevant principles of electrical engineering, the attack operating speed of AC asynchronous points can be calculated according to the following formula:

$$n = 60 (1f - s) / p \quad (1)$$

In the formula, the stator power supply frequency is represented by  $f$ ;  $p$  is the polar logarithm;  $s$  is the slip rate. From this formula, it can be seen that if the frequency of the stator power supply is changed at a constant speed, the synchronous operating speed of the motor would also undergo a stable change, thus obtaining a better regulated air volume. From a theoretical perspective, since the air flow rate is directly proportional to the first order of the rotational speed, and the air pressure is directly proportional to the square of the rotational speed, the shaft work is directly proportional to the third order of the rotational speed. From this point of view, compared to adjusting dampers, adjusting the operating rate would achieve a more significant energy-saving effect for the

boiler. In the energy-saving control system studied in this article, the actuator is a frequency converter. By adjusting the operating speed, the air blowing volume and water supply volume can be reasonably changed. The formula for calculating power savings is as follows:

$$\Delta = N H H Q (1 - 3)^* 2 \quad (2)$$

According to the theory of fluid mechanics:

$$P = \frac{Q}{H} \quad (3)$$

The air volume Q is proportional to the first power of the speed N, the pressure H is proportional to the second power of the speed N, the shaft power P is proportional to the third power of the speed N, and the motor speed N is proportional to the power frequency.

### 3. Experiment and Energy-Saving Controllers in Mechanical and Electronic Engineering

On this basis, a 4 kW three-phase induction motor is used as the research object, and an energy-saving control device is used, with an ammeter as the motor load [18-19]. In this experiment, the conventional technical parameters of the motor drive system were tested, and a comparative test of control variables was conducted. Except for the connection of energy-saving controllers, other operating modes and configurations were the same. Experiments were conducted on induction motors in the above two states, and the test results were analyzed. On this basis, through a series of comparative experiments, the problem can be quickly identified and more conclusions can be drawn. The specific meanings of each working condition in the horizontal axis are shown in Table 1.

Table 1. Motor load conditions corresponding to each working condition

Case number	Load rate
1	0
2	5
3	15
4	25
5	30
6	40
7	50
8	55
9	65
10	70

Here, the experimental process of this article includes the following aspects: firstly, record the corresponding voltage and current values in the three phases. The second is to connect the power plug properly. The console of the electromagnetic eddy current dynamometer sets the torque to 0, which is equal to no load. At the same time, the output electrical energy can also be measured on three phases. Thirdly, connect an electromagnetic force

meter and gradually increase the torque of the electromagnetic force meter, which is equivalent to gradually increasing the load of the induction motor. Every once in a while, the electrical energy display at its input end, as well as the voltage and current corresponding to the three phases, would be measured. Fourthly, repeat the above steps three times to ensure that the interval time and torque value are the same. Therefore, the comparison of stator current of induction motors in vehicles with and without energy-saving controllers is shown in Figure 4 [20].

As shown in Figure 5, the lower the load rate, the smaller the stator current, and the better the energy-saving effect. This is due to the increase in load, as the optimal magnetic flux tends towards the rated value, which also verifies the effectiveness of the minimum stator current control technology. The statistical diagram of the changes in power factor is shown in Figure 5 [21].

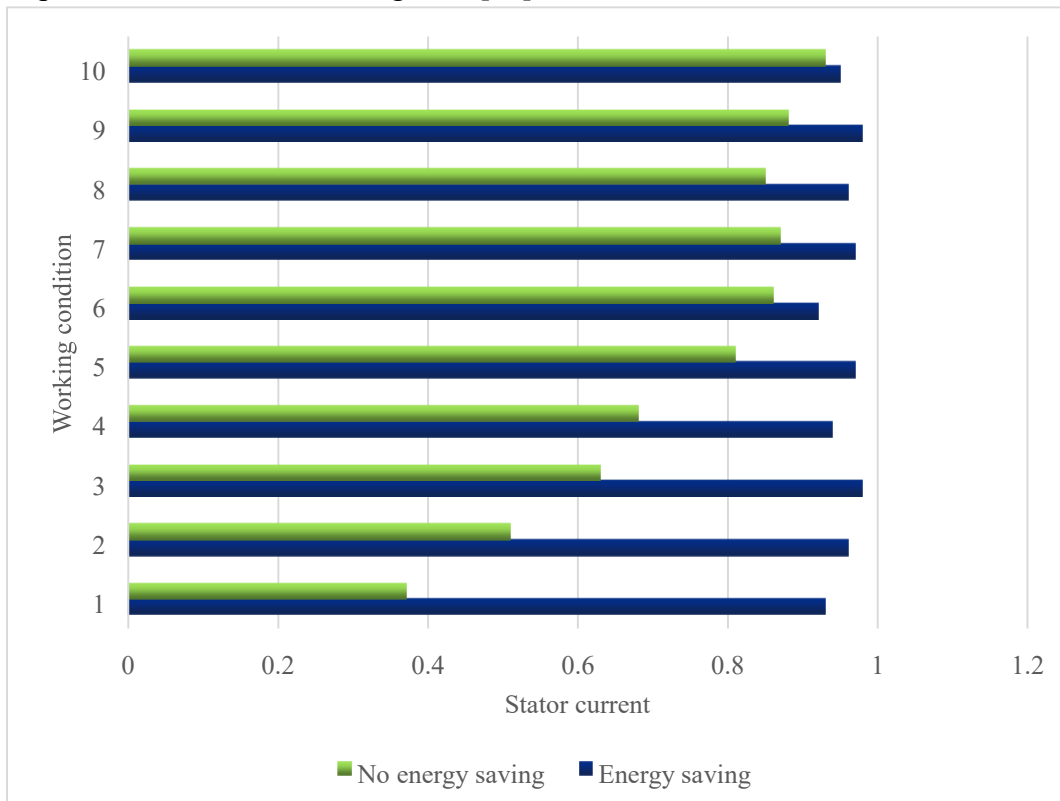

Figure 4. Comparison of stator current

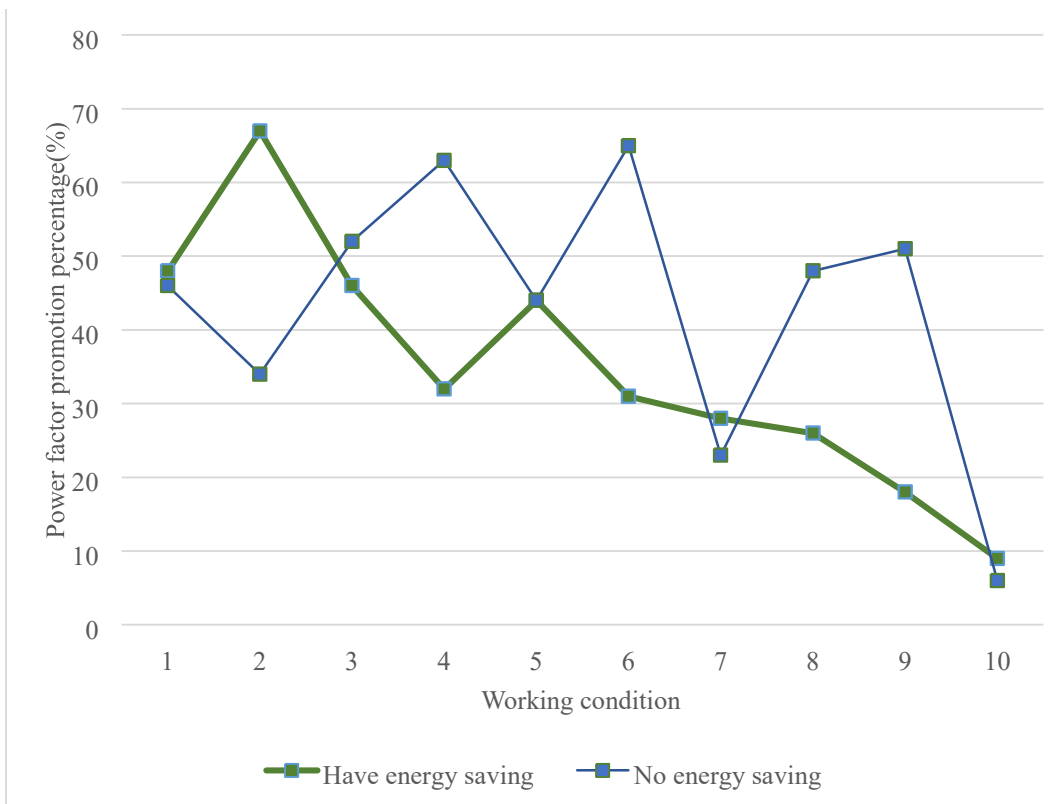

Figure 5. Improvement of power factor

As shown in Figure 5, under the condition of energy conservation, the improvement in condition 2 is the largest, with a value of 67%. Under the condition of not using any energy, the efficiency improvement under condition 6 is the highest, reaching 65%. The smaller the load ratio, the more significant the effect on improving power factor. This can not only save the active power consumption of the induction motor, but also effectively reduce the power consumption of the motor and improve the transmission performance of the motor.

During the experiment, every time the state is switched and the load of the asynchronous motor is changed, the energy-saving controller of the automotive asynchronous motor maintains good dynamic response characteristics. Throughout the entire experiment, there is no motor stall, and its various indicators are stable and reliable, basically meeting the needs of extending the range of electric vehicles. Therefore, it is an energy-saving supporting equipment for asynchronous motors used in electric vehicles with good practicality. So, after constructing an energy-saving control experimental platform for automotive asynchronous motors, this article tested the experimental device, and the feedback of the test results showed that the basic functions of this experimental platform were complete and reliable, ultimately achieving experimental research on energy-saving controllers for automotive asynchronous motors. By testing some of the main performance parameters of the energy-saving control system, various performances of the energy-saving control system were tested, and the performance of the energy-saving control system was also tested. The two main performance parameters and

dynamic and static operating characteristics of the energy-saving controller were experimentally studied through comparative experiments.

#### 4. Conclusions

The electrical equipment has undergone energy-saving transformation using electrical equipment and electrical equipment. Therefore, in future research work, it is also necessary to increase the exploration and exploration of energy-saving control technologies, continuously improve and enhance existing energy-saving control technologies, and promote the development of energy-saving control in mechanical and electronic engineering from multiple perspectives. Therefore, combining energy conservation technology with mechanical design would completely eliminate various difficulties that currently hinder the development of energy conservation technology, and play a huge promoting role in the development of mechanical design and manufacturing. In order to solve the problem of vector control and achieve high-speed dynamic response, some power losses may occur when the motor is unloaded or lightly loaded. Therefore, this paper proposes an energy-saving control technology for automotive asynchronous motors based on the minimum stator current method, which exchanges the optimal energy with a certain response speed under conditions of different load rates and no high demand for dynamic response.

#### References

- Huang Huacheng. "Analysis of Energy Saving and Consumption Reduction Technology In IOT Control System-Campus Energy Saving And Consumption Reduction Street Light System As An Example." *Turkish Journal of Computer and Mathematics Education (TURCOMAT)* 12.11 (2021): 3950-3957.
- Ashryatov, A. A., V. G. Kulikov, and A. V. Panteleyev. "Energy saving control system development for external lighting." *Indonesian Journal of Electrical Engineering and Computer Science* 17.3 (2020): 1601-1606.
- Chang Jun-yang, Jing Jin-song, and Wu Jun-yi. "Multi-hop based energy-saving control scheme for internet-of-things systems." *Journal of the Chinese Institute of Engineers* 45.6 (2022): 543-555. [4] Ding Renkai, Wang Ruochen, and Meng Xiangpeng. "Energy-saving control strategy design and structure realization for electromagnetic active suspension." *Proceedings of the Institution of Mechanical Engineers, Part C: Journal of Mechanical Engineering Science* 233.9 (2019): 3060-3075. [5] Zhang Biying, Jin Shangtai, and Hou Zhongsheng. "Energy saving control of bionic robotic fish based on model-free adaptive control." *IFAC-PapersOnLine* 53.2 (2020): 3934-3939.
- Xing Yazhou. "Optimisation of energy-saving control parameters of urban underground sewage treatment pumps based on fuzzy parameter adaption." *International Journal of Global Energy Issues* 42.5-6 (2020): 339-354.
- Xiuying Yan, Pengfei Yu, and Dengjia Wang. "Flexible Energy-Saving Control Strategy of a Solar-ASHP Integrated Heating System Based on Time-Sharing Heat Demand." *Distributed Energy Resources* 8.1 (2023): 1-10.

- Zheng, Mali. "Research on energy-saving control and optimisation of air conditioning system based on genetic algorithm." *International Journal of Global Energy Issues* 43.1 (2021): 38-54. [9] Jin Zheliang, and Martinez Davis. "Energy-saving control method of electric heating film temperature for urban zero energy consumption building heating." *International Journal of Global Energy Issues* 42.5-6 (2020): 323-338.
- Fung Rongfong, and Wu Tsung-Liang. "Dynamic formulation, identification and energy-saving control for an LCD glass-handling robot system." *International Journal of Dynamics and Control* 8.1 (2020): 1-20.
- Li Dongmei. "Analysis on the monitoring system of energy conservation and comfort in office buildings based on internet of things." *International Journal of Low-Carbon Technologies* 15.3 (2020): 351-355.
- Wen Xiaolong. "Research on an optimisation control method of large-scale buildings energy saving based on particle swarm optimisation." *International Journal of Global Energy Issues* 44.2-3 (2022): 166-181.
- Watanabe Shoichiro. "Verification of optimized energy-saving train scheduling utilizing automatic train operation system." *IEEEJ Journal of Industry Applications* 9.2 (2020): 193-200.
- Ding Damin. "Energy-saving optimization on active disturbance rejection decoupling multivariable control." *Nuclear Engineering and Technology* 55.3 (2023): 850-860.
- Chen Yu. "An Energy-saving Fuzzy Control Fan Array with Bluetooth Received Signal Strength Indicator Sensing." *Sensors and Materials* 34.9 (2022): 3449-3459.
- Fei Xiaotao, Yunwu Han, and Shaw Voon Wong. "An Overview of and Prospects for Research on Energy Savings in Wheel Loaders." *Automotive Experiences* 6.1 (2023): 133-148.
- Sun Xiaoye. "Research and evaluation of energy-saving reconstruction of intelligent community heating system based on the internet of things." *International Journal of Heat and Technology* 39.3 (2021): 701-710.
- Yang Guoqiang. "Adoption of Energy-Saving Materials in the Design of Hotel Intelligent System under Low Carbon Environment." *Integrated Ferroelectrics* 215.1 (2021): 256-266.
- Wang J. F. "Energy-saving operation of multistage stochastic manufacturing systems based on fuzzy logic." *International Journal of Simulation Modelling* 18.1 (2019): 138-149.
- Tingting Wang. *Design and Implementation of Environmental Protection Publicity Based on Green Energy Effect.* *Nature Environmental Protection* (2022), Vol. 3, Issue 3: 54-61.
- Ken Lawrence. *Resource Balance Optimization Method of Mechanical Engineering Project Considering Multi-objective Optimization.* *Kinetic Mechanical Engineering* (2023), Vol. 4, Issue 1: 1-10.