

Study on Single-phase Ground Fault Localisation in Distribution Networks Based on Transient Travelling Waves

Maiheliya maihemutijiang

School of Electrical Engineering, Southwest Minzu University, Chengdu, 610041, China

Abstract: China's low and medium voltage distribution networks are mostly grounded by small currents, and single-phase grounding faults are frequent and their fault characteristics are weak, so that the traditional fault localization schemes may fail. In order to effectively solve the problem of single-phase grounding fault localization in distribution networks, the traveling wave localization technology is applied in distribution networks, which is expected to realize fast and accurate fault localization in distribution networks. Firstly, the paper analyzes the characteristics of traveling wave signals in distribution networks and those in transmission networks, and proves the feasibility of the traveling wave localization method applied to distribution networks. Secondly, the transient electrical quantities after a single-phase ground fault occurs in the distribution network are characterized, and it is concluded that in the fault transient process, nonlinear and nonsmooth signals appear in the faulted and non-faulted lines, and effective information is extracted for fault localization using the traveling wave method. Finally, in the case of abnormal traveling wave data during fault localization, single-end localization is carried out using the initial wave head arrival moment and reflection wave arrival moment of the traveling wave signal of the side branch to ensure accurate localization, and simulation verification is carried out using PSCAD/EMPTDC.

Keywords: Distribution network, Double-ended traveling wave method, Anomaly data, Fault localization.

1. Introduction

The reliability of the distribution system is the main index to measure the ability of the power supply system to provide continuous power supply to the users, the distribution network is interrupted by short-term and long-term faults in the number of times and the duration of the power supply greatly affects the reliability of the power supply, the distribution network of fast, accurate fault localization is conducive to fault isolation of a small range of faults and rapid maintenance, for the safe, stable and efficient operation of the distribution network is of great significance.

Medium and low voltage distribution network branches are short and numerous, and the probability of failure is much higher than that of transmission network, among which, single-phase grounding faults have the highest probability of occurring, accounting for about 80% of the total faults in the distribution network [1], so single-phase grounding fault identification and localization of the distribution network has always been the focus of many experts and scholars. For a long time, the fault localization methods proposed by scholars at home and abroad can be roughly divided into two categories: active method [2,3] and passive method. The traveling wave method in the passive method takes the transient traveling wave generated at the fault point as the object of analysis, which is not affected by the system operation mode [4], and does not require pulse injection equipment, and has better practicability and economy compared with the active method, and has become a hotspot of research in recent years, and has been widely used in fault localization of power transmission networks [5], and in recent years, the use of traveling wave method for fault location in distribution network has been widely concerned, but due to the complex network topology of the distribution network and

the short lines, the refraction and reflection of the traveling wave leads to the initial wave head of the traveling wave is difficult to be identified, which makes fault location in distribution network difficult, and the traveling wave acquisition device needs to be able to communicate with the control system of the electric power company in order to realize the accurate early warning and localization of the traveling wave faults in the distribution network, so it has a higher requirement for the communication. Therefore, the communication requirements are high. Failure of the traveling wave acquisition device itself, communication failure, missing or distorted data in the communication process, and communication time delay will cause inaccurate fault localization in the distribution network, which is collectively referred to as the occurrence of anomalies, and the collected data is called abnormal data. When abnormal data exists, the fault localization process will continue, but the fault localization result will have a large error. Therefore, it is very important to identify abnormal data and perform fault localization in the presence of abnormal data.

The traveling wave method is most widely used in single-ended and double-ended traveling wave methods. The classical single-ended traveling wave method does not rely on data synchronization, but it needs to detect the arrival time of the traveling wave reflected from the fault point [6], and the traditional double-ended traveling wave method relies on data synchronization even though it only needs to detect the incident traveling wave at both line terminals [7]. In addition, regardless of the single-ended traveling wave method or double-ended traveling wave method, accurate fault localization has a great relationship with the line parameters, inaccurate line parameters have a greater impact on the calculation error of traveling wave speed, which results in a larger localization error [8]. Literature [9] uses double-ended traveling wave method for fault localization, but in the

traditional double-ended traveling wave method at both ends of the line to detect the incident traveling wave arrival time in addition to the arrival time of the reflected wave from the arrival of the reference end of the fault point to detect the arrival time of the reflected wave, which generates a double-ended fault localization formula that is independent of the propagation speed of the fault travelling wave and thus does not depend on power line parameters. However, this method requires high double-ended synchronization accuracy. In the literature [10-11], single-ended and double-ended traveling wave localization methods are applied taking into account the delay effect of the communication system by using the local fault locator clock as the reference time and synchronizing the waveform data by stepping the communication channel delay. Literature [12] proposes a single-ended traveling wave localization method that requires neither knowledge of the propagation speed of the faulty traveling wave nor synchronization of the data at both ends. However, this method uses the arrival time between the arrival time of the first faulty traveling wave and the arrival time between the successive reflections from the fault point and the far-end line terminals as the time difference, which requires high accuracy in the identification of the traveling waveheads, and consequently higher data accuracy. Although the above methods consider synchronization accuracy and communication delay, they do not consider the handling of abnormal data in the fault and communication process of the traveling wave acquisition device.

This paper proposes a processing method for abnormal data in the traveling wave localization process, which overcomes the above deficiencies. According to the relationship between the initial traveling wave arrival moment of each traveling wave acquisition device and the distance, it judges whether the traveling wave acquisition device or communication data is abnormal, reports the abnormal data and sets the abnormal data to zero, and adopts the data of the traveling wave acquisition device of the branch on the side to assist in locating the faults of the branch containing abnormal data, so as to minimize the fault location error caused by the abnormal data as much as possible.

2. Single-phase Ground Fault Traveling Wave Localization Principle

The traveling wave method performs fault ranging by detecting the propagation time of the transient traveling wave on the faulted line between the bus and the faulted point, and its basic principle [13], as shown in equation (1).

$$x = vt \quad (1)$$

where x denotes the distance from the fault point to the line terminal detection point; v denotes the propagation speed of the traveling wave in the overhead cable; and t denotes the time at which the initial traveling wave head arrives at the traveling wave acquisition device.

In the ideal case, assuming that there is no refracted wave from the fault point to the line terminal, the fault location can be accurately calculated by using (1) after extracting the initial traveling wave head, but due to the phenomenon of wave reflection and refraction, if there is a reflected wave from the neighboring bus to the detection point, it may lead to fault localization errors.

Eq. (2) is the principle formula for double-end localization, taking the M end of the line terminal as the beginning and N as the end, and using the initial traveling wave arrival times recorded at the line terminals M and N, the fault location is calculated by using the difference in the arrival time of the initial traveling wave head.

$$l_d = \frac{L_{MN} + v \times (t_M - t_N)}{2} \quad (2)$$

Where, l_d is the distance of fault d from substation M; L_{MN} is the distance from line M to N; v is the propagation speed of traveling wave in the overhead line blue; t_M , t_N are the moments when the initial traveling wave head arrives at the line terminals M and N, respectively;

In Eq. (2), it can be seen that the traveling wave fault localization results are related to the full length of the line, the wave speed and the initial traveling wave head arrival moment. The line length L is usually a parametric quantity held by the utility^[14], but there may be some errors^[15]. If there is an error, the line length can be accounted for using equation (1)^[16], thus reducing the effect of line length. Since the traveling wave speed is determined by the medium, the fault location accuracy is determined by the initial traveling wave head arrival moment. The data collected by the traveling wave acquisition device is the driving force to realize the whole fault monitoring, relying on the voltage and current to monitor the operation of the distribution system in real time, and the data abnormality will directly affect the accuracy of fault localization.

3. Localization of Single-phase Ground Faults in Distribution Networks in The Presence of Anomalous Data

As shown in Figure 1, this paper proposes a fault location method for distribution network containing abnormal data, firstly, the terminal of the distribution network is equipped with traveling wave detection device to obtain the traveling wave signal of the distribution network, since the traveling wave is issued by the fault point, the initial traveling wave head arrival time will be proportional to the distance between the terminal data and the fault point, and the initial traveling wave heads collected by the traveling wave acquisition device of many terminals are arranged in accordance with the law of the length of the distribution network line. The initial traveling wave head collected by many terminal traveling wave acquisition devices is arranged according to the distribution network line length law, and when the data at a certain point does not conform to the arrangement law, the system will recognize that the data at this point is abnormal, and will use the side branch traveling wave data for fault localization, and ultimately get the fault localization result of the traveling wave of the distribution network containing abnormal data.

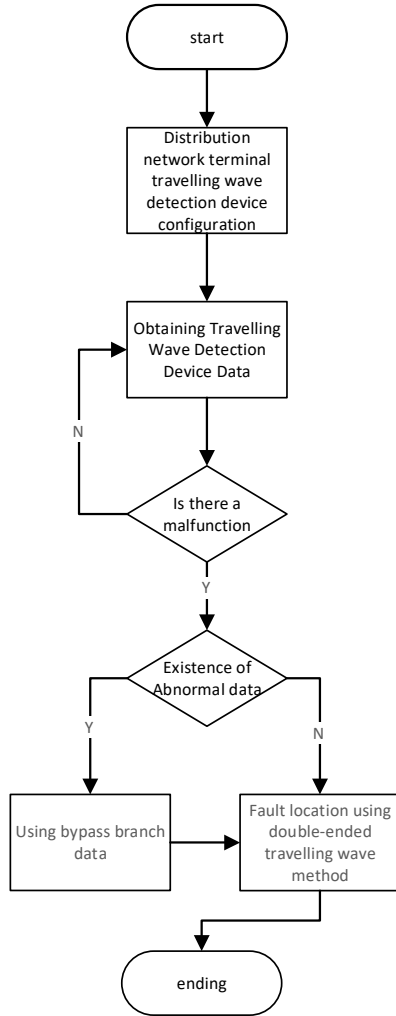

Figure 1. Fault localization process

As shown in Figure 2, traveling wave acquisition device is installed at both ends of the main feeder to form the main positioning device: traveling wave acquisition device is installed in the distribution transformer at the end of each branch as the auxiliary positioning device. Through the GPS / BeiDou miniature timing system for synchronous timing, when a fault occurs, the fault traveling wave acquisition device will collect the initial traveling wave head arrival time, uploaded to the master station, the master station for data

integration and calculation, and then accurately locate the fault location.

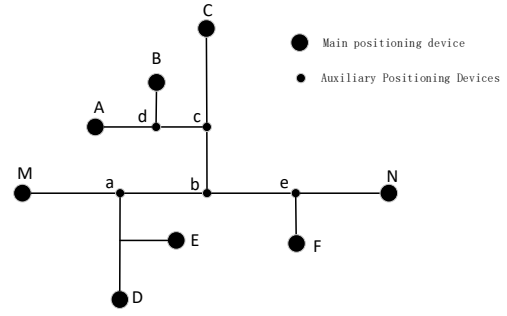

Figure 2. Typical distribution network topology

Figure 3 shows a simple distribution network, the length of each line is known, set the fault at d1, according to the principle of double-ended traveling wave localization, one line end is selected as the reference point, and the other line ends are the detection points. Taking the first end detection point as the reference point, the fault distance between the first end and each detection point can be calculated. The signals collected by the four collecting devices are transmitted to the main station, assuming that the system will use two auxiliary localization points, A and B, for fault localization when there is abnormal data in the collected data at point N at the end of the line.

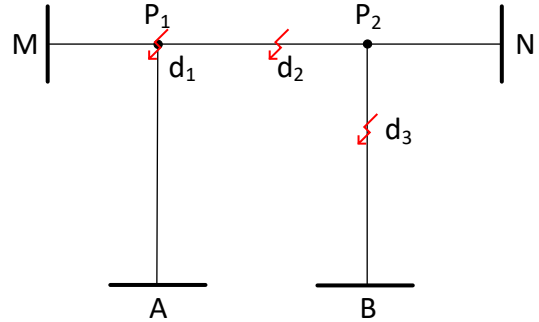

Figure 3. Simple distribution network

Table 1 lists the localization results of different fault points with different detection points as reference ends.

Table 1. Fault localization results

fault point		d1		d2		d3	
reference point		M	N	M	N	M	N
Distance to Fault	M	0	l_{NP_1}	0	$l_{NP_2} + l_{P_2d_2}$	0	l_{NP_2}
	N	l_{MP_1}	0	$l_{MP_1} + l_{P_1d_2}$	0	$l_{MP_1} + l_{P_1P_2}$	0
	A	l_{MP_1}	l_{NP_1}	l_{MP_1}	$l_{NP_2} + l_{P_2d_2}$	l_{MP_1}	l_{NP_2}
	B	l_{MP_1}	l_{NP_2}	$l_{MP_1} + l_{P_1d_2}$	l_{NP_2}	$l_{MP_2} + l_{P_2d_3}$	$l_{NP_2} + l_{P_2d_3}$
fault point		d1		d2		d3	
reference point		A	B	A	B	A	B
Distance to Fault	M	l_{AP_1}	$l_{BP_2} + l_{P_2d_1}$	l_{AP_1}	$l_{BP_2} + l_{P_2d_2}$	l_{AP_1}	l_{Bd_3}
	N	l_{AP_1}	l_{BP_2}	$l_{AP_1} + l_{P_1d_2}$	l_{BP_2}	$l_{AP_1} + l_{P_1P_2}$	l_{Bd_3}
	A	0	$l_{BP_2} + l_{P_2d_1}$	0	$l_{BP_2} + l_{P_2d_2}$	0	l_{Bd_3}
	B	l_{AP_1}	0	$l_{AP_1} + l_{P_1d_2}$	0	$l_{AP_2} + l_{P_2d_3}$	0

The fault localization results of different reference ends are listed in Table 1., assuming that when point d1 is faulty, the data of detection point M is abnormal, the system will use point N as the reference end, and the double-ended traveling

wave localization using the data of both points N and A can accurately determine the fault location. However, when the fault point is located between the detection point M and the node P1, it can only know that the fault is between the point

M and the point P1, but it cannot determine the exact location of the fault.

4. Simulation Analysis

In order to verify the proposed method in this paper, PSCAD/EMTDC is used to build the distribution system as shown in Fig. Each branch line is connected to a Dyn-type connected distribution transformer at the end of each branch line, and the ratio of the transformer is 230 kV/10 kV. A

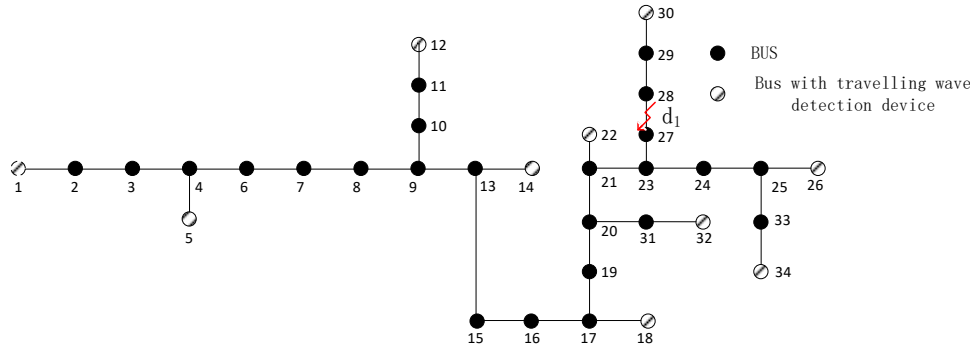

Figure 4. IEEE34 Node Distribution Networks

Fault d_1 is used as an example for detailed explanation.

According to the principle of double-ended traveling wave localization, node No. 1 is the beginning, and the initial traveling wave arrival time recorded at detection points No. 1 and No. 26 is used to determine whether the fault occurs on the main feeder:

$$l_d = \frac{L_{1, 26} + v \times (t_1 - t_{26})}{2} \quad (3)$$

where l_d is the propagation distance of the traveling wave on the main feeder, $L_{1, 26}$ is the distance between node 1 and node 26, t_1 is the initial traveling wave arrival time recorded by the detection device at node 1, t_{26} is the initial traveling wave arrival time recorded by the detection device at node 26, and v is the line mode wave speed. Based on the calculation results, it is obtained that the fault occurs at node 23 or on a branch line directly connected to node 23. To further determine the specific location, the initial traveling wave arrival time recorded by the detection device on node 26 and the detection device on node 30 is brought into equation (2) to calculate the specific fault location, and the calculation result is between node 27 and node 28, according to node 27 at 529 meters, with an error of 29 meters, which is within the acceptable error range.

5. Conclude

The distribution network fault location method with abnormal data proposed in this paper utilizes the data recorded by the traveling wave detection device at the line terminals for double-ended traveling wave localization, and when the system discovers abnormal data, the abnormal data will be deleted so as not to affect the fault localization results, and then the data recorded by the side-end traveling wave detection device will be used for fault localization to complete the accurate localization of faults in the distribution network when abnormal data exists; however, when the traveling wave data at the terminal end of the faulty branch occurs abnormally, it is only possible to carry out zone fault

traveling wave acquisition device is installed at the terminal substation of each branch line to collect the voltage traveling wave signals, and the sampling frequency is set to 1 MHz, so that the original signals are subjected to a Clarke transform, and the traveling waveforms of the lines are obtained. The Clark transform is applied to the original signal to obtain the traveling waveform of the line, and then the wavelet packet transform is applied to the signal for 3-layer decomposition. The fault d_1 , located between node 27 and node 28, 500 meters away from node 27, is set in the simulation model.

localization to locate the faulty branch, and it is not possible to carry out the accurate fault ranging, and the method will be improved in the subsequent research.

Acknowledgment

This work was financially supported by the Innovative Research Project for Postgraduate Students of Southwest Minzu University (YB2022122).

References

- [1] GUO Qingtao, WU Tian. A Review of Fault Routing Methods for Small Current Grounding Systems [J]. *Power System Protection and Control*, 2010, 38(02):146-152.
- [2] YU Shengnan, BAO Hai, YANG Yihan. Practical methods for fault location on distribution lines [J]. *Proceedings of the CSEE*, 2008(28):86-90.
- [3] LI Peipei, HUANG Jiadong, ZHAO Yonglei. Study on single-phase ground fault localisation in distribution networks based on double-ended non-simultaneous ranging [J]. *Journal of Electric Power Science and Technology*, 2011, 27(08):20-23.
- [4] JI Tao. Travelling-wave fault location and phase selection in small-current grounding systems using electromagnetic voltage transformers [J]. *Transactions of China Electrotechnical Society*, 2012, 27(08):172-178.
- [5] ZENG Xiangjun, CHEN Nan, LI Zewen, et al. Network-based fault travelling wave localisation algorithm [J]. *Proceedings of the CSEE*, 2008(31):48-53.
- [6] JI Tao, SUN Tongjing, XU Bingyin, et al. Study on fault location of distribution mixed feeders based on double terminal method of traveling waves [J]. *Proceedings of the CSEE*, 2006, 26(12): 89-94.
- [7] ZHENG X X, SHANG Y D, PENG X M. Orbital stability of periodic traveling wave solutions to the generalized zakharov equations [J]. *Acta Mathematica Scientia (English Series)*, 2017(4): 998-1018.
- [8] CHAI Peng, ZHOU Hao, ZHANG Yu, et al. Improvement of short-circuit fault location in cable lines based on double-ended

- travelling wave method [J]. *Electric Power*,2020,53(11):168-174.
- [9] GILANY M, IBRAHIM D K, TAG ECDIAC E S. Traveling-wave-based fault-location scheme for multi end-aged underground cable system[J]. *IEEE Transactions on Power Delivery*, 2007, 22(1):82–89.
- [10] LOPES F V, SILVA K M, COSTA F B, et al. Real-time traveling-wave-based fault location using two-terminal unsynchronized data[J]. *IEEE Transactions on Power Delivery*, 2015, 30(3): 1067–1076.
- [11] Hang, et al. Analysis of time delay jitter of communication system on fault location of power line based on traveling wave method[J]. *Telecommunications Science*,2018, 34(3): 170–176.
- [12] SCHWEITZER E O, GUZMAN A, MYNAM M V et al. Protective relays with traveling wave technology revolutionize fault locating[J]. *IEEE Power & Energy Magazine*, 2016, 14(2): 114–120.
- [13] ZHANG Yuanyuan, ZHU Yongli, ZHANG Ning, et al. Research of fault location for multi-terminal transmission lines based on phase comparison[J]. *High Voltage Apparatus*, 2018, 54(1): 57–63.
- [14] ZHANG Pan, ZHANG Yu, DING Yi, et al. Fault location for low voltage active distribution network based on perturbation method[J]. *Electric Power*, 2018, 51(12): 63–71.
- [15] JU Yong 'an, LIU Cong, SHAN Rutao, et al. Identification and location of single-phase line-broken fault of arc-suppression coil grounding system[J]. *Electric Power*, 2017, 50(8): 113–117.
- [16] ZHOU Junhui, YANG Yi, SUN Huijun, et al. A method of traveling wave fault location without setting wave velocity and line length[J]. *Electrical Measurement & Instrumentation*, 2015, 52(19): 117–122.