

# Changes in Welding Angle and Current Voltage

Yukun Wang, Hangxin Wei, Le Qin, Pengpeng Zhang, Yijun Liu

School of Mechanical Engineering, Xi'an Shiyou University, Xi'an, Shaanxi 710065, China

**Abstract:** This article mainly studies the impact of changes in the angle of the weld seam groove on the welding current and voltage during welding. Different angles of the groove are selected for zigzag welding using a welding gun. The simulation results show that there is a significant change in current and voltage during the actual welding process as the angle of the groove changes. At the same time, it can also be derived in reverse based on the changes in current and voltage.

**Keywords:** Welding groove, Current, Voltage.

## 1. Introduction

At present, pipeline welding has important significance in multiple fields. Firstly, in industrial production, the reliability of pipeline systems, as a critical component, has a crucial impact on production and personnel safety. Welding[1], as the most commonly used and effective manufacturing method in pipeline installation, can weld pipeline components into a whole, ensuring their integrity and reliability. Only when the pipeline is properly welded can the pressure and temperature during operation be reasonably controlled and transmitted. Therefore, the improvement and application of welding technology plays an important role in improving pipeline reliability and stability. Secondly, the pressure bearing capacity of pipelines is crucial for their safety. If the pressure bearing capacity of the pipeline system is insufficient, it may lead to serious accidents such as pipeline leakage or explosion. Welding, as an effective reinforcement method, can improve the pressure bearing capacity of pipeline systems, thereby preventing pipeline explosions or leaks caused by sudden pressurization and other reasons[2]. This means that welding is not only related to the safety of pipelines, but also has important significance in ensuring the safety of relevant personnel and equipment.

In addition, from an economic perspective, the improvement of welding technology can also improve the construction efficiency and reduce costs of long-distance pipeline projects. This is mainly reflected in multiple aspects such as saving welding materials, improving welding efficiency[3], and improving welding quality. At the same time, improvements in welding technology can also improve the durability and stability of pipelines, thereby reducing the frequency of pipeline maintenance and replacement, indirectly saving related economic costs.

## 2. Selection of Simulation Materials

According to the commonly used standards for oil and gas pipelines, in order to approach the real welding environment, the simulation material used here is X-60 low alloy steel, which is also the main material for the vast majority of pipelines in China's West East Gas Pipeline Project. The commonly used diameter of the pipeline is 508-1219mm. In this simulation, the pipe diameter is 800mm, and the pipeline wall thickness is 30mm. The welding wire diameter is 1.0mm low alloy steel[4], which can improve the tensile strength of the welding points, Suitable for butt welding of steel plates

and lap welding of steel bars. It can effectively improve welding efficiency, save welding rods, reduce electricity consumption, and reduce construction costs.

## 3. Simulation Experiment Environment

In order to approach the real welding environment of carbon dioxide shielded welding more closely, this simulation experiment was conducted in a gas filled with carbon dioxide. The conductivity of carbon dioxide gas is 20-40s/m, and the dielectric constant is 1. The welding voltage at the end of the welding gun is 30v, the voltage at the groove is 0v, and the welding current is 40A. The conductivity of the slope and welding wire is 1000000-10000000 m/s, and the dielectric constant is 6[5].

## 4. Geometric Model of Groove

The following is a schematic diagram of the geometric model of the welding groove, which shows a general geometric fracture, while the other half is clearly symmetrical. By changing the  $\alpha$  The size of the weld groove changes the angle of the welding groove, and the spacing between the two fractures and the distance between the bottom and bottom of the fractures are fixed.

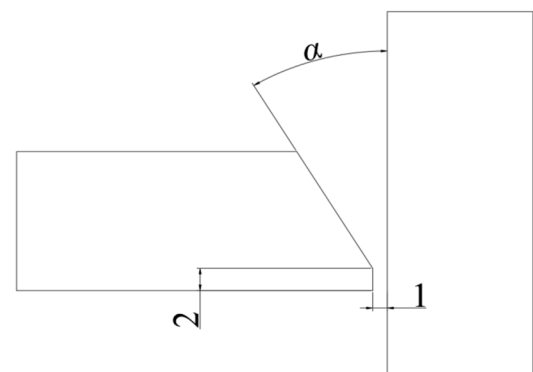

Figure 1. Schematic diagram of welding groove model

## 5. Schematic Diagram of Welding Process

This welding process adopts a zigzag welding, and the overall welding process is shown in the figure. The initial position of the welding gun is located in the middle of the two

grooves. This welding process is carbon dioxide protection welding, and the entire process is carried out in a carbon dioxide environment. The changes in current and voltage also change with the position of the welding gun[6]. This is because the change in distance between the welding gun and the weldment can affect the length and impedance of the welding arc.

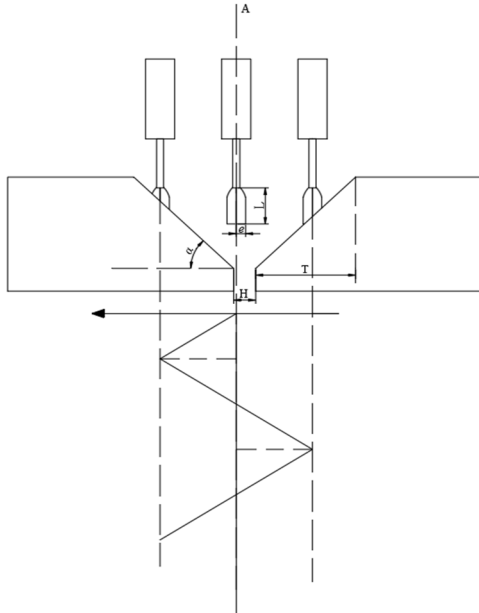

Figure 2. Schematic diagram of welding process

The length of the welding arc is influenced by the relationship between welding current and voltage. During the welding process, the closer the distance between the welding gun and the weldment, the shorter the length of the welding arc; On the contrary, the farther the distance, the longer the length of the welding arc. There is a certain relationship

between the length of the welding arc and the arc voltage. When the length of the welding arc changes, the arc voltage will also change accordingly[7]. The change in distance between the welding gun and the weldment can also cause changes in the impedance of the welding arc. Impedance refers to the degree of resistance of the welding arc to the current, which is closely related to the length of the welding arc. When the distance between the welding gun and the weldment changes, the impedance of the welding arc will also change accordingly, resulting in a change in the welding current.

The variation of current and voltage follows Ohm's law:

$$V = I * R$$

In the process of carbon dioxide welding, the relationship between the voltage and current of the welding gun and the groove distance can be described by the welding arc model:

$$V = \begin{cases} \frac{2e * L}{K} & A \in (H) \\ \frac{2e(x) * L + 2e(1-x) * L * \tan\alpha}{K} & A \in (T, H) \\ \frac{2e * L * \tan\alpha}{K} & A \in (T) \end{cases} \cup (H, T)$$

Among them  $K = \epsilon * \sigma$ , Where  $\epsilon$  is the dielectric constant,  $\sigma$  is the conductivity. The initial speed of the zigzag welding of the welding gun is running at a speed of 5mm/s both horizontally and in the welding direction. According to the above model, when the welding gun is in the initial position in the middle of the weld seam, the voltage is at its maximum[8]. As the welding gun gradually approaches the groove during the zigzag welding process, the voltage gradually decreases, and then increases after reaching the edge and returning[9].

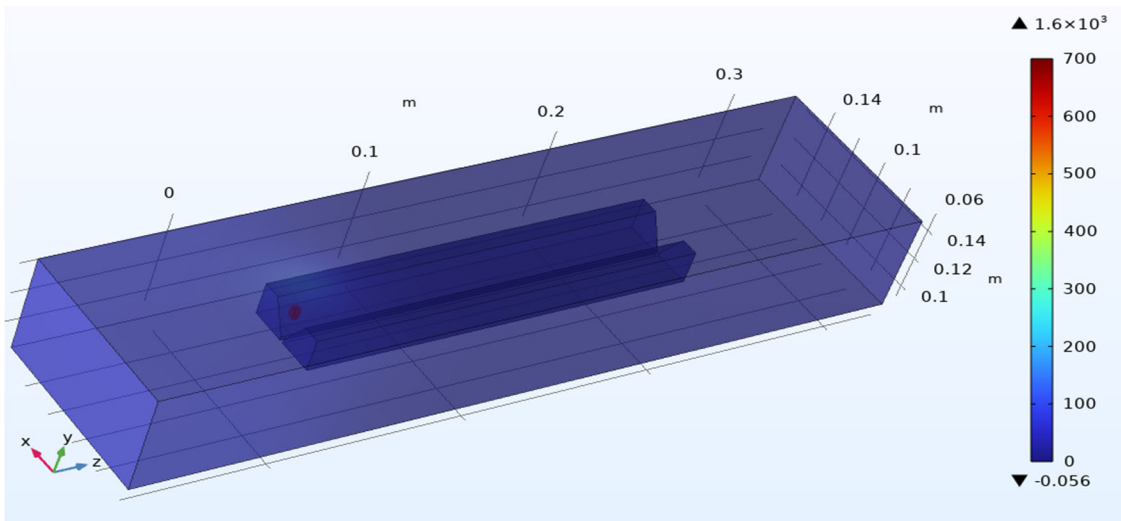
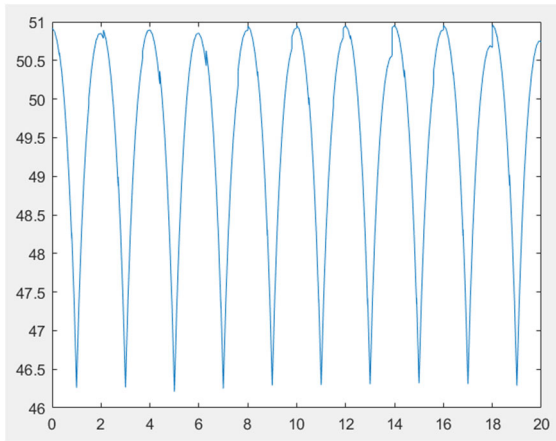

Figure 3. Schematic diagram of welding 3D model

The following is a schematic diagram of a 3D welding model. The dark color in the middle of the figure represents the fracture model, and the light color around it represents a carbon dioxide environment.

The following analysis shows the voltage results for welding groove angles of 60 ° -100 °. Here, every ten degrees are taken as a stage analysis, with a running time of 20 seconds. The results are as follows:



**Figure 4.** 60 degree voltage diagram

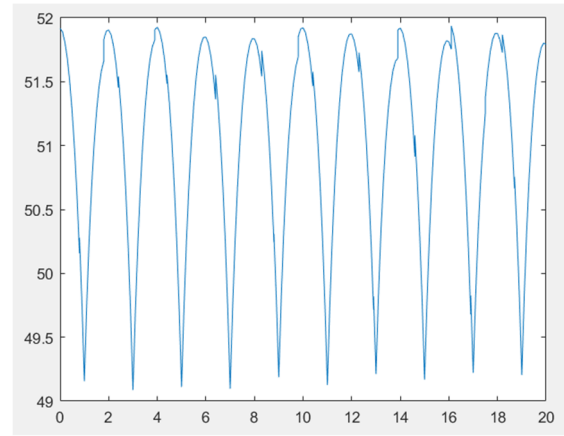

**Figure 5.** 70 degree voltage diagram

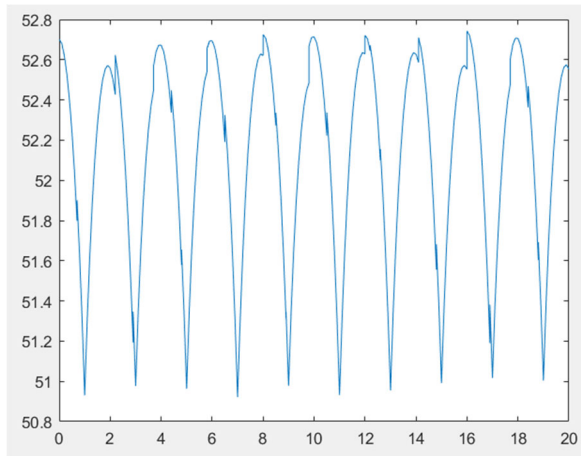

**Figure 6.** 80 degree voltage diagram

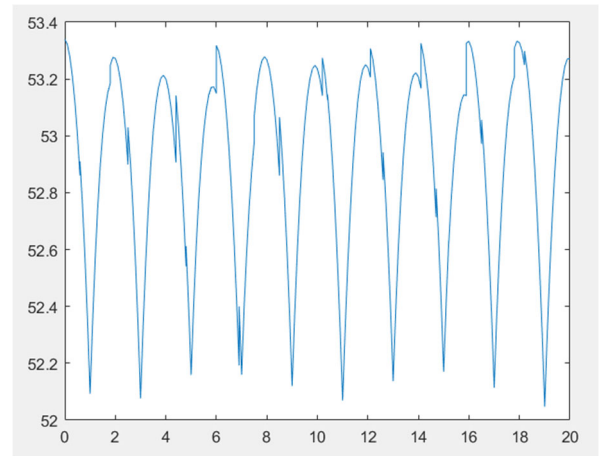

**Figure 7.** 90 degree voltage diagram

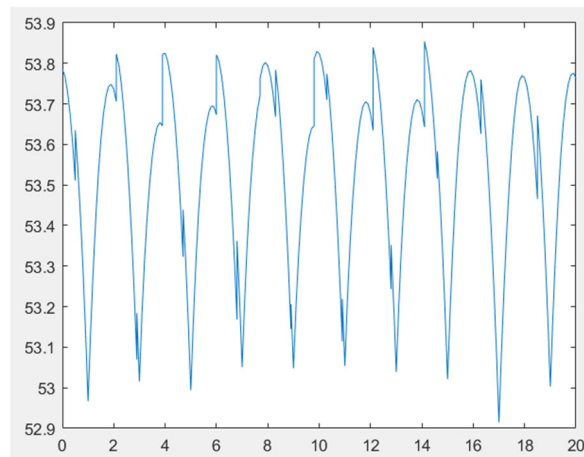

**Figure 8.** 100 degree voltage diagram

## 6. Conclusion Analysis

According to the simulation results, the carbon dioxide zigzag welding method changes with the angle of the weld groove, and the voltage also changes accordingly. The voltage is inversely proportional to the angle of the welding groove, and the voltage stability becomes poor. Moreover, when the welding groove angle is not known, the welding groove angle can also be classified based on the voltage value of the welding gun.

## References

- [1] Huo Houzhi, Huang Cheng, Zhang Yucai, et al. Research on the calculation method of welding process parameters for arc welding robots [J]. *Welding Pipe*, 2015 (8): 34-37.
- [2] Xu Jianning, Zhang Hua, Hu Jinhua, et al. The relationship between welding process parameters and weld geometry size in fusion welding rapid prototyping [J]. *Welding Technology*, 2008, 37 (4): 10-13.
- [3] Zhang Mingmin, Hu Yue, Wu Jiayun, et al. The effect of electron beam welding parameters on the morphology of small penetration welds in high-temperature alloys [J]. *Hot working process*, 2017 (1): 233-235.

- [4] Xie Qingsheng, Wang Yingjun Analysis of Factors Influencing the Quality of Welding Products by Welding Process Specification Parameters [J] Gansu Science and Technology, 2006, 22 (9): 85-86.
- [5] Zuo Shiwei, Yu Zhishui, Jing Nan Factors affecting welds [J] Journal of Shanghai University of Engineering and Technology, 2010, 24 (3): 272-274.
- [6] Chen Ying. Design and Development of an Experimental Device and Measurement and Control System for Adjusting the Height of a Coal Mining Machine [D]. Huainan: Anhui University of Science and Technology, 2019.
- [7] Su Qiang. Research on Leakage Control of the Hydraulic System of the MXG350 Coal Mining Machine Traction Part [D] Guiyang: Guizhou University, 2008.
- [8] Yang Ming. Carbon dioxide gas shielded welding construction technology [J]. Shanxi Architecture, 2012, 38 (19): 123-125.
- [9] Song Sijun. Discussion on CO<sub>2</sub> gas shielded welding operation technology for inclined 45 ° pipe to pipe butt joint with flux cored welding wire [J]. Education, 2014 (4): 59-60.