

# Structural Design and Analysis of Battery Cell Winding Machine

Weiguo Wu<sup>1, a</sup>, Guangbin Wang<sup>1</sup>, Xiaohui Wang<sup>1</sup>, Tuchao Pang<sup>1</sup>, Junnan Qiu<sup>1</sup> and Tanchang Guo<sup>2</sup>

<sup>1</sup>School of Mechanical and Electronic Engineering, Lingnan Normal University, Zhanjiang, Guangdong 524048, China

<sup>2</sup>Zhongshan JianBin vocational school, Zhongshan, Guangdong 528400, China

<sup>a</sup>3446411375@qq.com

**Abstract:** This article aims to address the issues currently faced by domestic battery cell winding machines, including small size, low production efficiency, poor winding accuracy, and low product yield. To overcome these challenges, we have taken a step further by optimizing the key structure and automatic control system of a small semi-automatic battery cell winding machine. As a result, we have successfully developed a fully automatic battery cell winding equipment capable of producing large-sized battery cells. By constructing a comprehensive machine experimental platform and conducting thorough experimental verification of battery winding, we have achieved full automation of the battery cell winding process. This significant progress has led to improvements in efficiency, accuracy, and product yield. Consequently, our study offers a practical solution for the optimization design of battery cell winding machines.

**Keywords:** Battery cell winding machine; Production efficiency; Key structures; Automatic control system; optimal design.

## 1. Introduction

With the rapid development of industrial modernization and the increasing demand for energy, lithium batteries have become a crucial component in energy storage. In the production and manufacturing process of lithium batteries, the winding of battery cells plays a critical role. The structure and level of automation of the battery cell winding machine directly impact the dimensions, yield, processing efficiency, and forming accuracy of the wound finished cell. Therefore, the battery cell winding machine equipment holds significant importance in cell winding and forming. Currently, China's research, development, and production capabilities in battery cell winding equipment are relatively weak. The country heavily relies on imported automatic cell winding machines or low automation, low stability manual, semi-automatic, and single-machine equipment. These imported automatic cell winding machines often encounter maintenance difficulties, while battery cell winding machines with lower automation levels suffer from drawbacks such as small size, low production efficiency, poor winding accuracy, and low product yield. In response to market demand, this article focuses on the design and optimization of battery cell winding machine equipment. By optimizing the key structure and control system, we have developed a fully automatic battery cell winding machine that exhibits high precision, stability, and the ability to produce larger sizes with higher product

yield. This innovative design solution offers a new approach for optimizing the battery cell winding machine.

## 2. Structural Composition and Process Analysis of The Winding Machine

### 2.1. Technical requirements for winding battery cells

Lithium batteries, as crucial energy storage devices, come in various types. They can be classified differently based on classification standards. The battery shapes determine the classification into square lithium batteries and cylindrical lithium batteries. Additionally, based on the production method of battery cells, they can be categorized as stacked lithium batteries and coiled lithium batteries. This article focuses on the design and study of a battery cell winding machine specifically tailored for producing wound cylindrical battery cells. To meet the demand for large-sized battery cells, we have optimized the key structure and control system of the winding machine. This optimization ensures that the machine can produce qualified large-sized battery cells. Table 1 presents the relevant parameters of the produced large-sized battery cells. Through the process of optimizing the design and enhancing the winding machine, our objective is to improve production efficiency, enhance the quality and stability of the finished battery cells, and meet the market demand for large-sized battery cells.

**Table 1.** Battery cell related parameters

Diameter(mm)	Height(mm)	winding speed(Pieces/min)	Winding accuracy
175	270	1~2	Ensure the alignment of the positive and negative electrode plates, the alignment of the diaphragm, and the alignment error of the diaphragm to the electrode plate is controlled within $\pm 1$ mm;

## 2.2. Structural composition of the winding machine

The present article focuses on the design of a battery cell winding machine, which is composed of various essential components as described below: 1. Unwinding Mechanism for Positive and Negative Electrode Plates and Diaphragms: This mechanism facilitates the placement and unfolding of positive and negative electrode plates as well as diaphragms, ensuring a continuous supply of materials. 2. Tension Control Device: The tension control device maintains a consistent tension throughout the winding process, thereby preventing material breakage or relaxation. 3. Deviation Correction Control Device: The deviation correction control device ensures the alignment and centering of the material during the winding process, effectively rectifying any potential deviations. 4. Material Belt Feeding Mechanism: The material belt feeding mechanism precisely feeds the positive and negative electrode plates as well as diaphragms into the winding mechanism, guaranteeing accurate positioning. 5. Winding Mechanism: The winding mechanism is responsible for winding the positive and negative electrode plates as well as diaphragms onto the core shaft, thereby forming the structure of the battery cell. 6. Automatic Cutting Belt Mechanism: Upon completion of the winding process, the automatic cutting belt mechanism severs the material belt, thereby separating individual battery cells. 7. Gluing Mechanism: The gluing mechanism is employed to apply adhesive and enhance the structural strength of the battery cell. 8. Cell Pressing Mechanism: The cell pressing mechanism firmly secures the completed cells, preventing any potential displacement or damage. 9. Automatic Winding and Needle Drawing Auxiliary Mechanism for Battery Cells: This auxiliary mechanism facilitates the needle drawing and connection of battery cells subsequent to the automated winding process.

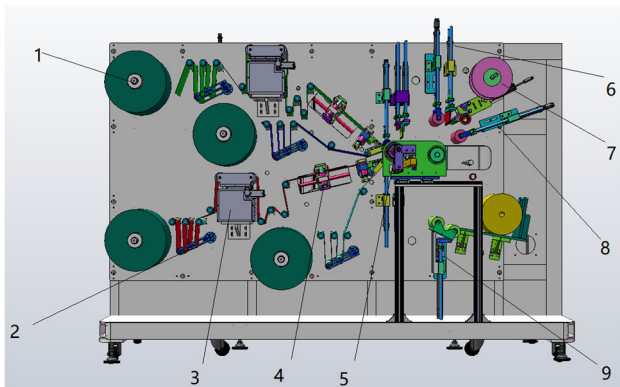

Figure 1. Structural diagram of battery cell winding machine

## 2.3. Process Analysis of Winding Machine

The control system of the winding machine enables the automatic, efficient, and precise winding production of battery cells through the coordinated movement of various mechanisms. The process flow of the battery cell winding machine is illustrated in Figure 2.

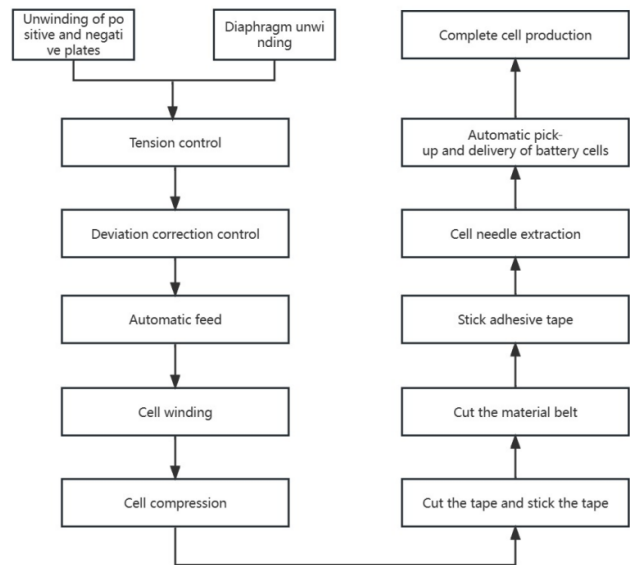

Figure 2. Process flow diagram of battery cell winding machine

When it comes to winding battery cells, the battery cell winding machine operates as follows: Firstly, the positive and negative electrode plates and diaphragm unwinding mechanism initiate automatic and balanced unwinding actions. The respective material belts pass through the tension mechanism and deviation correction mechanism, guided by the guide roller and material belt automatic feeding mechanism. This enables the transportation of positive and negative electrode plate material belts, as well as diaphragm material belts, to the winding position of the needle mechanism. The battery cells are then wound in the following sequence: positive electrode, separator, negative electrode, and separator. Once the winding process is completed according to the predetermined parameters, the cell pressing mechanism firmly presses the cell to prevent any loosening. Subsequently, the automatic cutting belt mechanism uses a cutting knife to sever the belt, while the adhesive mechanism ensures proper bonding of the battery cell. Finally, the auxiliary mechanism of automatic winding and needle picking facilitates the extraction and automatic retrieval of large battery cells.

## 3. Key Structural Design

With the increase in the winding diameter of battery cells, battery cell winding machines face several challenges during the winding process. The uni-directional drive is difficult to ensure a constant tension in the battery cell during the winding process. Additionally, after the winding is completed, due to the large size and weight of the battery cell, there is significant friction between the winding needle surface and the battery cell contact surface during the needle extraction process, making it difficult to separate the winding needle from the battery cell. A considerable force is required to extract the needle from the cell. Moreover, after needle extraction, it is difficult to ensure the surface flatness of the battery cell, and the flatness of the side surface is also poor, severely affecting the quality of battery cell winding. Therefore, to meet the requirements of large-scale energy storage battery cell winding, it is necessary to design its key structure. We have designed a battery cell automatic

winding and needle extraction auxiliary mechanism to address the challenges of tension fluctuation during the winding of large-diameter battery cells and the difficulties in needle extraction and the poor surface flatness of the cell after needle extraction. Through this mechanism, it is possible to achieve high-precision and automatic winding of large-diameter battery cells, as well as assist in automatic feeding and delivery of cells.

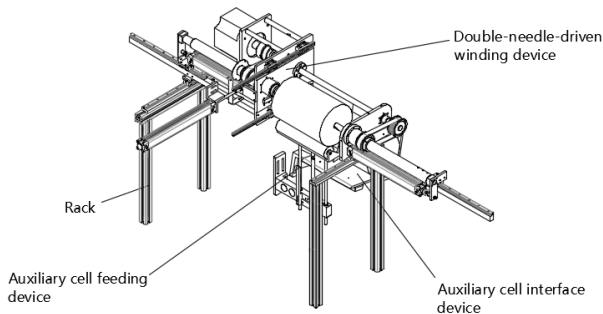

**Figure 3.** Automatic Winding and Needle Drawing Auxiliary Mechanism for Battery Cells

### 3.1. The structural design of the Double-needle-driven winding device

The structure of the double-needle-driven winding device mainly consists of an electric motor drive shaft, needle spool back plate, drive servo motor, needle retraction connecting plate, slide rail, synchronizing wheel, timing belt, square cylinder, needle spool front plate, sliding connecting block, and needle spool mechanism. During the winding process of the battery cell, the double-needle-driven winding device positions the positive and negative electrode sheets and separator material between the two needle spools of the winding mechanism. Initially, the servo motor is driven to rotate the motor drive shaft. Through the transmission of the synchronizing wheel and timing belt, the winding mechanism synchronously rotates, thereby driving the two needle spools to rotate in sync for the winding action, thus achieving the winding of the battery cell. Compared to traditional cell winding devices that use single-axis single-side driving for winding, the double-needle-driven winding device utilizes a set of drive components to achieve dual-drive winding with two needle spools. This ensures that the driving force for winding the cell is evenly distributed on both sides of the needle spools. As a result, during the winding process of the battery cell, especially for large-diameter cells, a uniform and constant tension can be maintained, ensuring better winding flatness and stability. Consequently, the quality of the battery cell winding can be effectively improved.

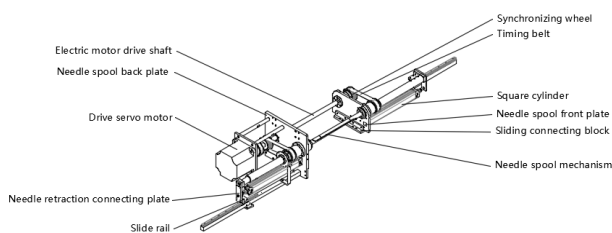

**Figure 4.** Double-needle-driven winding device

### 3.2. The structural design of Auxiliary cell feeding device

The structural design of the auxiliary cell retrieval device mainly consists of the following components: tail wheel, rotating shaft, cylinder guide plate, circular push rod cylinder, cylinder guide shaft, material feeding push rod, tail wheel base fixing plate, and tail wheel fixing seat. After the completion of battery cell winding, the drive servo motor stops rotating. The square-shaped vertical stroke cylinder drives the cylinder push plate and the needle hanging plate, which in turn moves the dual needle driving winding device as a whole to the right. The movement stops when it touches the limit switch. The cylinder guide plate acts as a fixed component. The push rod of the circular push rod cylinder is securely connected to the tail wheel base fixing plate through a connecting head. The tail wheel fixing plate can rotate as it is connected to the rotating shaft and the tail wheel fixing seat. The circular push rod cylinder of the cell retrieval and tail collection auxiliary mechanism starts to move. It pushes the tail wheel base fixing plate through the cylinder push rod and then drives the tail wheel fixing seat to move towards the direction of the wound large-size cell through the axial positioning of the rotating shaft. This causes the tail wheel on the tail wheel fixing seat to make contact with the cell core. When the tail wheel supports the large-size cell, the laser sensor and gravity sensor switch are triggered, causing the circular push rod cylinder to stop pushing. The auxiliary cell retrieval device holds the cell, transferring the weight from the needle to the tail wheel, thereby eliminating the friction between the needle and the cell caused by gravity. The needle withdrawal action is then performed. The square-shaped cylinders on the left and right sides move the needle withdrawal connection plate and the slide rail connection block in a linear guide by pushing the push rod. The needle withdrawal connection plate, connected to the needle withdrawal connection block, drives the main spindle of the needle to move in the opposite direction on both sides. The main spindles on both sides, along with the two side needles, perform the needle withdrawal motion. After the needle is fully withdrawn, the needle is completed, and the cell falls onto the auxiliary cell retrieval device.

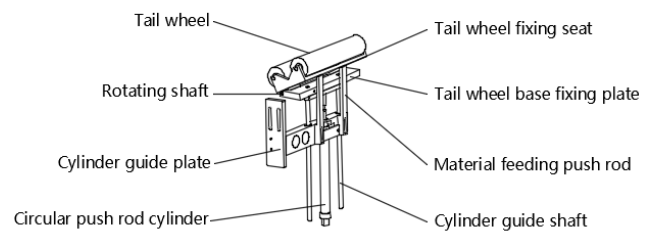

**Figure 5.** Auxiliary cell feeding device

### 3.3. The structural design of Auxiliary cell interface device

The auxiliary core connection device is mainly composed of a cell stopper board, cell receiving board, and core connection frame. After the battery cell winding machine completes the pin withdrawal action, the auxiliary core retrieval device moves downward with the lifting drive component, driving the lifting plate and support seat to move downward. The cell follows the downward movement and eventually moves to the unloading position. The unloading

push rod pushes the support seat to an appropriate inclined angle, allowing the auxiliary core retrieval device to come into close contact with the auxiliary core connection device, and automatically slide the cell into the auxiliary core connection device. The rolling friction between the tail wheel and the cell is small, ensuring that the cell slides smoothly without damaging its surface, achieving a smooth and automatic unloading process from the tail wheel into the auxiliary core connection device. In this way, the automatic unloading operation of the cell is effectively realized.

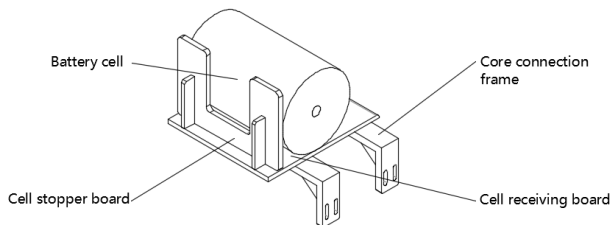

Figure 6. Auxiliary cell interface device

## 4. Control System Design

### 4.1. Hardware design

Due to its strong anti-interference capability, simple programming language, strong expandability, and good stability, two KV-N60AT PLCs from Keyence were chosen as the main controllers in this control system. One PLC serves as the master station controller, while the other one serves as the slave station controller. Since the I/O ports of the CPU are limited, the following additional units were selected for input and output expansion: KV-N8EXT input expansion unit, KV-N8EX output expansion unit, KV-N1 connection conversion unit, KV-NC4AD A/D analog conversion unit, and KV-N11L serial communication extension box. The hardware connections for these units are illustrated in Fig.7.



Figure 7. Relevant hardware wiring diagram

### 4.2. Program design

The program is primarily designed based on the process and functional requirements of battery cell winding on the winding machine. By setting relevant parameters, the control system achieves the fully automated process of battery cell winding. The automatic program design flow of this control system is shown in Figure 8. Upon startup, the system initiates parameter initialization and opens the main air source for all

pneumatic cylinders to initiate their reset. Once the cylinders have completed resetting, the positive and negative electrode sheets and separator material are loaded for the cell winding process, and the parameters for cell winding are set. In the control panel, the automatic mode is selected, and the large-scale battery cell winding machine automatically completes the entire cell winding process. Firstly, the feeding mechanism automatically feeds the positive and negative electrode sheets as well as the separator. Once the feeding is in place, the dual-needle drive winding device moves to the pre-winding position, and the left and right needles begin needle insertion. Then the pre-winding action is initiated. After the pre-winding is completed, the film alignment and mold reset are performed, followed by the continuation of the cell body winding. Once the winding is finished, the upper and lower film clamps and mold actions are performed, and the finishing wheel of the feeding mechanism presses the bottom of the battery cell. Subsequently, the cutting knife starts to cut off the positive and negative electrode sheets and separator tape, and right after that, the gluing mechanism initiates the gluing action. The gluing and tape applying actions are then carried out. After the glue application is completed, the cutting action is executed, followed by the finishing action of the feeding mechanism. Lastly, the left and right winding needles start to retract, and the feeding mechanism automatically retrieves the cell, completing the entire battery cell winding process.

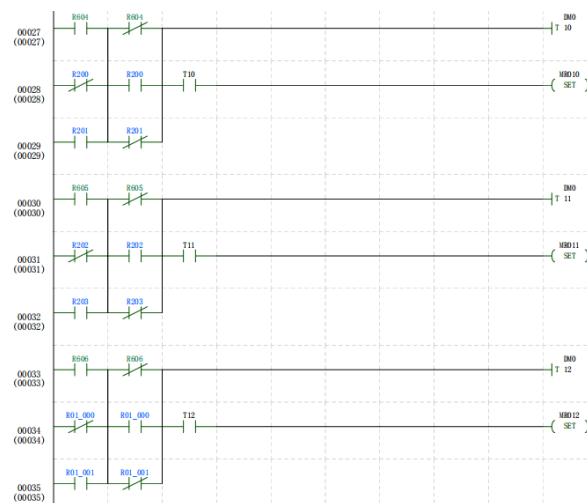

Figure 8. Partial control program ladder diagram

### 4.3. Human-machine interface design

The human-machine operation interface is the primary interface of the large battery cell winding machine. In this interface, real-time monitoring of the machine's operating status, selection of control modes, and parameter settings can be achieved. The main interface is shown in Figure 9. The overall air source switch on the page enables the control system to control the cylinders of the winding machine. By pressing the permission login button, users can enter the permission login interface and input the management account and password to set permission parameters. The middle device status display box allows monitoring and display of the real-time operating status of the winding machine. In the production capacity display box, operators can set the desired quantity of continuous battery cell production. The current production quantity shows the number of battery cell products produced by the equipment. When the preset production quantity is reached, the winding machine stops the winding

production process. The automatic mode button allows switching between manual and automatic modes. Pressing the reset button will reset all cylinders and motor-controlled mechanisms to their initial positions. The alarm clear button, when pressed after adjusting the equipment status following an abnormal alarm, can clear the alarm information. The linkage/manual button enables switching between linkage and jog modes. In linkage mode, the winding machine can achieve continuous battery cell winding production, while in jog mode, each press of the start button completes one motion of the winding machine. The bottom row allows switching between different interfaces, including manual page, recipe data, parameter settings, and historical data interfaces.

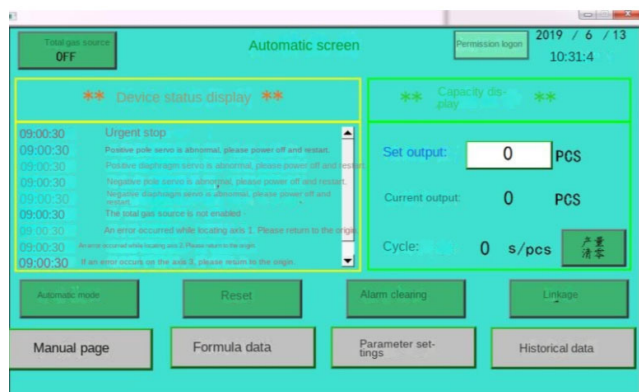

Figure 9. Operation main interface

## 5. Summary

In this study, we focused on the design and optimization of key structures and control systems for a small-scale semi-automatic battery cell winding machine. Through the construction of an optimized battery cell winding machine, we conducted battery cell winding tests and successfully manufactured individual battery units using the wound cells. The results demonstrated that the produced battery cells meet the required production standards. This study provides a valuable reference for the optimization design of battery cell winding machines, offering insights for future improvements in the field.

## 6. Research Funding

1. 2022 Guangdong Provincial Basic and Applied Basic Research Fund Enterprise Joint Fund (Offshore Wind Power) project "Intelligent Diagnosis Technology for Shaft Current Damage of Offshore Wind Turbine Generator Based on Multi-Domain Adaptive Approach" (2022A515240043);
2. Zhanjiang City Science and Technology Plan Project (2021B01190);
3. Guangdong Higher Education Society Laboratory Management Professional Committee Fund Project (GDJ20220272);
4. Lingnan Normal University Natural Science General Project (YB2112) ;

5. Zhanjiang Science and Technology Project (2021B01458)

## References

- [1] Suo Luomin, Li Hong. The past and future of lithium-ion batteries[J]. Physics, 2020, 49(01): 17-23.
- [2] Sun Yushu, Yang Min, Shi Zhangli, Jia Dongqiang, Pei Wei, Sun Lijing. Analysis of application status and development trend of energy storage[J]. High Voltage Engineering, 2020, 46(01): 80-89.
- [3] Wang Gaojun, Fu Lijun, Zhao Nahong, Yang Lichun, Wu Yuping, Wu Haoqing. An aqueous rechargeable lithium battery with good cycling performance.[J]. Angewandte Chemie (International ed. in English), 2007, 46(1-2).
- [4] Yan Jinding. Development status and prospect analysis of lithium-ion batteries[J]. Journal of Aeronautical Science, 2014, 35(10): 2767-2775.
- [5] Zhang Hongmei, Ming Wuyi, Peng Bi, Chen Zhong. Research on key technologies of fully automatic winding machine for lithium-ion power batteries[J]. Electromechanical Engineering & Technology, 2016, 45(05): 25-29.
- [6] Lü Shuhui. Research on software design and deviation control of lithium battery winding equipment[D]. Harbin Institute of Technology, 2010.
- [7] Dong Fengming. Analysis of China's lithium battery equipment industry[J]. Special Equipment for Electronic Industry, 2016, 45(04): 6-11+55.
- [8] Chen Zhenxing. Design and implementation of embedded control system for square lithium-ion battery winding machine based on DSC[D]. Guangdong University of Technology, 2015.
- [9] Xie Linfei, You Linru, Wang Lisong. Design of fully automatic winding machine controller for lithium-ion battery based on PC104 and PLC[J]. Combined Machine Tools & Automatic Processing Technology, 2009(10): 62-65.
- [10] Yang Sheng. Variable-speed motion control of battery winding machine based on PLC programming technology[J]. Electrician's Technology, 2011(02): 35-36.
- [11] Bi Xiuguo, Bu Fanling. Improvement design and experiment of key mechanism for high-speed polyester filament winding machine[J]. Journal of Dalian Polytechnic University, 2014, 33(03): 232-234.
- [12] Liu Yanjie, Wu Mingyue, Wang Gang, Cai Hegao. Optimization design method of silicon wafer transfer robot arm structure[J]. Journal of Mechanical Engineering, 2015, 51(01): 1-9.
- [13] An Fuqiang, Zhao Hongliang, Cheng Zhi, Qiu Jiyicheng, Zhou Weinan, Li Ping. Development status and research progress of lithium-ion batteries for pure electric vehicles[J]. Journal of Engineering Sciences, 2019, 41(01): 22-42.
- [14] Qu Nan, Ding Hongwei, Du Zhaocai, Zhang Rui. Design of control system for robot automatic riveting[J]. Machine Tool & Hydraulics, 2021, 49(09): 46-50.
- [15] Liu Yanhua, Qian Na. Design of slide rope protection system for friction hoist based on PLC[J]. Coal Mine Machinery, 2021, 42(05): 184-187.