

# Research on UAV Fixed-point Delivery Problem Based on Aerodynamics

Lulu Wang\*

School of Mechanical and Electrical Engineering, Sanjiang University, Nanjing, 210012, China

\*Corresponding author

**Abstract:** Aiming at the problem of UAV fixed-point delivery. In this paper, the air resistance model in the aerodynamic model is combined with Newton's second law to construct an efficient solution to the ball projection problem at low speed. Firstly, the motion of the ball is decomposed into two directions: horizontal and vertical. By simplifying the model, the horizontal flight distance of the ball under three wind directions is obtained, and then the delivery distance of the aircraft is obtained. Secondly, considering the function of UAV to perform the blasting task, the aircraft used a certain Angle of dive, and subject to the distance constraints, followed by the dynamic model. Finally, through numerical iteration, the dive Angle of the aircraft under the wind direction and the straight-line distance between the position of the aircraft when it is launched and the target were obtained. Under the influence of different wind direction and wind speed, the aerodynamic model that can calculate the position and dive Angle of the UAV when it is launched at fixed point is obtained according to the direction and size of the influencing factors.

**Keywords:** Aerodynamic Model, Air Resistance Model, Newton Second Law.

## 1. Introduction

With the continuous development of science and technology, many material delivery tasks are gradually carried out by Uavs instead of humans.

Uavs have also become important data acquisition equipment in anti-terrorism and disaster relief operations, and have shown unique potential and performance advantages[1] in fire protection, environmental investigation and earthquake rescue in deep forests. The most important function of unmanned aerial vehicles (Uavs) performing fixed-point delivery tasks in the air is nothing more than the delivery accuracy of stability in the execution of the task. The delivery accuracy not only depends on the operation and flight technology of the UAV, but also is related to the state and environment of the UAV during the execution of the task, such as the height and speed of the UAV when approaching the delivery point. The wind speed at the location of the UAV, the geographical environment around the delivery point and other factors are all decision variables for whether the UAV can hit the target stably and accurately. Its motion state is decomposed to analyze its speed in all directions, the dynamic model is established and the characteristics are analyzed, and the external disturbance and model structure uncertainty are considered to meet the performance requirements of the flight control system[2].

It is of great significance to further solve the flight time and distance of the ball for the UAV fixed-point delivery problem.

## 2. Materials and Methods

This paper adopted the May 2023 A topic mathematical contest in modeling (<https://51mcm.cumt.edu.cn/d8/19/c14143a645145/page.htm>) is analyzed and studied.

## 3. Model Establishment and Solution

### 3.1. Basic model of UAV flight attitude

#### 3.1.1. Establishment of model

It is assumed that the aircraft flies normally and is not restricted by the wind during the whole process of delivery. The spherical materials it places are affected by the air resistance and the wind during the falling process, and the materials have velocities  $v_n$  in three directions and displacements  $L_n$  in each direction.

According to the above assumptions, for this problem, only the conditions required for the spherical materials to fall to the specified position after throwing are analyzed. See Figure 1 for details.

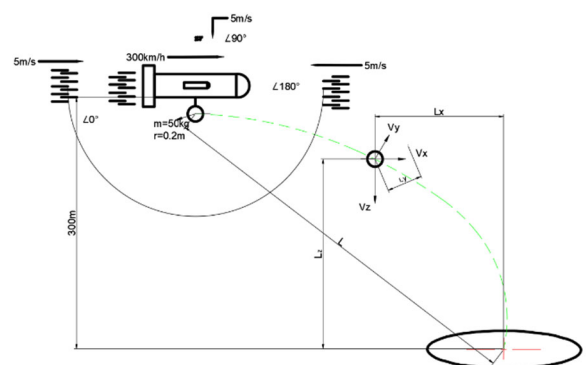
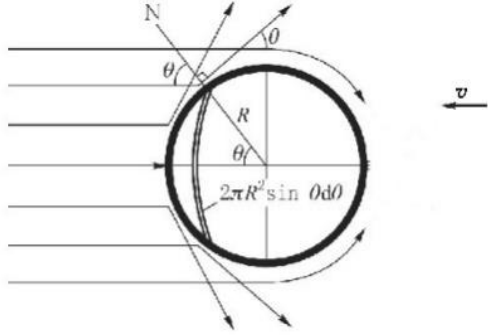

Figure 1. Motion analysis diagram of spherical materials placed horizontally

Under the conditions of three known wind directions and wind speeds, the additional speed of the wind will displacement the sphere in a corresponding direction, so the final delivery distance is synthesized by the displacement of the sphere in each direction.

Firstly, the air resistance [3] of the sphere in the air is calculated. The air resistance consists of two parts: one is the

resistance  $F_d$  of the windward side right in front of the sphere, and the other is the pull resistance caused by the vortex behind the sphere. In this problem, the influence of eddy current and turbulence on the motion of the small ball is ignored through problem simplification, and only the resistance in front of the ball is considered. See Figure 2 for details.



**Figure 2.** The wind resistance of the sphere in the air

Since the sphere is different from ordinary flat objects, the surface of the sphere is continuously changing, so in order to determine the resistance in front of it, the integral is used to calculate it.

The first step is to decompose the first half of the sphere in Figure 2 into a combination of many rings. Set on each ring with central Angle  $\alpha$  and opening Angle  $d\alpha$ , and the area of the rings is  $2\pi r^2 \sin \alpha d\alpha$ .

According to the literature, when the air flow on the upwind surface encounters the ring with the center Angle  $\alpha$  as the position, the velocity of the air flow is  $v \sin \alpha$ . According to the kinetic energy theorem, the following formula can be obtained:

$$\begin{cases} A = \pi r^2 \\ F = \frac{1}{2} A \rho v^2 \sin^2 \alpha \\ Fv\Delta t = \frac{1}{2} \int_0^{\frac{\pi}{2}} \rho \cdot 2\pi r^2 \sin \alpha d\alpha \cdot \cos \alpha \cdot v\Delta t \cdot (v \sin \alpha)^2 \Rightarrow F_f = \frac{1}{4} \rho v^2 A \quad (1) \\ F = \rho \pi r^2 v^2 \int_0^{\frac{\pi}{2}} \sin^3 \alpha \cos \alpha d\alpha \end{cases}$$

$F_f$  is the air resistance of a spherical object of radius  $r$  when its velocity is  $v$ .

Next, the influence of wind  $v$  on the delivery process of spherical materials under different wind directions is analyzed separately:

① In the case of downwind, that is, the direction of the wind speed is consistent with the direction of the aircraft projecting the sphere, because the wind speed is slow. In the above simplified model, the initial wind speed at the moment and the initial speed of the ball have been superimposed, and the resistance of the ball is mainly calculated by the relative speed of the ball and the air.

Next, we just need to figure out  $t$  how long it takes for the ball to reach the ground if it is in free fall and under the influence of wind resistance.

According to the influence of wind speed on the sphere under different wind direction, the model is established respectively, and the projection distance in three cases is solved.

$$\begin{cases} v_x = v_0 \pm v_{wind} \text{ (Tailwind, Headwind)} \\ mg - ma - F_f = 0 \\ a = g - \frac{F_f}{m} \\ H = \frac{1}{2} at^2 \\ L_x = v_x t - \frac{1}{2} a_x t^2 \\ a_x = \frac{F_f}{m} \\ \begin{cases} v = v_0 \\ v_y = v_{wind} \\ L_x = v_x t \end{cases} \text{ (Vertical Wind)} \end{cases} \Rightarrow \begin{cases} t = \sqrt{\frac{2H}{a}} \\ L = \sqrt{H^2 + L_x^2} \text{ (Tailwind, Headwind)} \\ L = \sqrt{H^2 + L_x^2 + L_y^2} \text{ (Vertical Wind)} \end{cases} \quad (2)$$

### 3.1.2. Solution of the model

The relationship between air resistance coefficient, gravity acceleration and velocity was determined by the cross-sectional area of the ball, and then the dynamic model and Newton's second law were used to iterate.

Finally, it is concluded that the landing time of the ball is  $t = 8.129$  seconds. At this point, the movement of the ball stops, and the horizontal movement distance of the ball under the influence of the wind speed can be calculated by the determined dynamic model.

① In the case of downwind, the initial velocity of the projection of the sphere is known as:

$$v_x = \frac{v_0}{3.6} m/s = 83.3 m/s \quad (3)$$

The wind speed  $v_w = 5m/s$  is known, so it is superimposed on the velocity of the sphere in the same direction:

$$v'_x = v_x + v_w = 88.3 m/s \quad (4)$$

The synthetic original velocity  $v'_x$  and air resistance model are iterated under the constraint of time  $t = 8.129s$ . The final result is obtained  $L_x = 571.3011m$ .

According to the distance synthesis calculation formula  $L = \sqrt{H^2 + L_x^2}$  when the wind is downwind, the delivery distance of the aircraft is obtained  $L = 645.279m$ .

② In the case of upwind, the initial velocity and the upwind wind speed of the sphere are known. The original velocity of the sphere is obtained as follows.

$$v''_x = v_x - v_w = 78.3 m/s \quad (5)$$

The synthetic velocity  $v''_x$  and air resistance model are iterated under the constraints of time  $t$ . The final result is obtained  $L_x = 517.8954m$ .

According to the distance synthesis calculation formula  $L = \sqrt{H^2 + L_x^2}$  when the wind is upwind, the aircraft's delivery distance when the wind is upwind is obtained  $L = 598.5112m$ .

③ In the case of vertical wind, the initial velocity and vertical wind speed of the sphere are known. The original velocity of the sphere is obtained as follows.

$$\begin{cases} v'''_x = 83.3 m/s \\ v_y = 5 m/s \end{cases} \quad (6)$$

The same can be obtained  $L_x = 544.8736m$ ;  $L_y = 40.645m$ ;

According to the distance synthesis formula  $L = \sqrt{H^2 + L_x^2 + L_y^2}$  in vertical wind, the landing distance of the aircraft in vertical wind is obtained  $L = 623.3294m$ .

### 3.2. Basic model adjustment of UAV flight attitude considering blasting delivery function

#### 3.2.1. Establishment of model

In order to achieve higher accuracy than the horizontal airdrop method, the dive airdrop method is proposed: firstly, the fixed-wing aircraft approaches the target from a large height, and then dives to it at a certain Angle while aiming. After releasing the projectile, the fixed-wing aircraft pulls up its fuselage and flies away, and the projectile falls to the target[5] in a nearly straight trajectory.

It is assumed that the final launch position and dive Angle of the UAV are determined under the precondition that the explosives finally hit the target. In addition, the effects of gravity acceleration, wind speed and air resistance on the aircraft and explosives are ignored in the process of UAV diving. Only the effects[6][7] of gravity acceleration, wind speed and air resistance after the launch of explosives are considered.

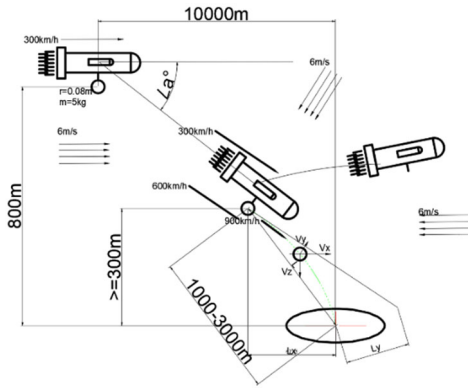

Figure 3. UAV bombing motion model diagram

Analyze the conditions required for a spherical explosive to fall to a specified location after launch. See Figure 3 for details.

In Question II, we continue to use the influence of the three wind directions in Question I. According to the air resistance model in problem 1, the horizontal delivery is changed to the target delivery at a certain inclination Angle  $\theta$ . At this time, the speed of the projectile  $v$  is the sum of the speed of the UAV  $v_1$  and the launching speed  $v_2$ .

To study the whole process from the time the explosive is launched to the time it hits the target, we need to decompose this velocity  $v$  at a certain Angle  $\theta$  into a horizontal velocity  $v_x$  and a vertical velocity  $v_z$ . The relationship between the two and the total velocity  $v$  is as follows:

$$\begin{cases} v_x = v \cos \theta \\ v_z = v \sin \theta \end{cases} \quad (7)$$

The initial values of the movement state of the spherical explosive in all directions at the moment of launching are obtained.

With the help of the air resistance model in Question 1, the following conclusions are drawn:

$$F_f = \frac{1}{4} \rho v^2 A \quad (8)$$

The aircraft starts to land from the cruising altitude and always maintains a constant speed, that is, it always maintains a force balance at this stage. Because the parameters of some factors that affect the lift and drag of the aircraft change constantly during the descent process, this paper fits the change curve and takes the optimal value to change it into a fixed value for building the model[8].

First of all, we assume that the plane has dived to the altitude  $H_{bow}$  when dropping the bomb, and the ball explosive reaches the hit point after a horizontal distance  $L_{level}$  after launching. Secondly, in order to determine the final forward distance of the explosive in the horizontal direction, it is necessary to obtain the time  $t_{down}$  consumed by the explosive to fall on the ground in advance, and decompose the entire process of projecting the explosive into a vertical linear motion with variable acceleration and a horizontal linear motion with variable deceleration. These two motions are solved separately, and the distances of the two motions are finally synthesized. The specific relationship is as follows:

$$\begin{cases} mg - ma - F_f \\ a = g - \frac{F_f}{m} \Rightarrow t_{down} = \frac{-v_z + \sqrt{v_z^2 + 2aH_{bow}}}{a} \\ H_{bow} = v_z t_{down} + \frac{1}{2} a t_{down}^2 \\ L_{level} = v_x t_{down} - \frac{1}{2} a_1 t_{down}^2 \\ a_1 = \frac{F_f}{m} \\ v_x' = v_x + v_{wind} \text{ (Tailwind)} \Rightarrow L = \sqrt{H_{bow}^2 + L_{level}^2} \\ v_x'' = v_x - v_{wind} \text{ (Headwind)} \\ \begin{cases} v_y = v_{wind} \text{ (Vertical Wind)} \\ v_x = v_x \end{cases} \Rightarrow L_{level} = v_x'' t_{down} - \frac{1}{2} a_1 t_{down}^2 + v_y t_{down} \end{cases} \quad (9)$$

With the final fall time of the spherical explosive, we can figure out how far the explosive will eventually travel in the horizontal direction. The horizontal motion of the spherical explosive has three different states of motion according to three wind directions. In the case of vertical wind, the wind speed is perpendicular to the horizontal direction of the explosive and provides a lateral offset speed. At this moment, the motion trajectory of the spherical explosive is changed from two-dimensional to three-dimensional. It is assumed that the horizontal displacement of the spherical explosive driven by the wind speed is not affected by the air resistance.

#### 3.2.2. Solution of the model

Within the computational framework of the above model, the constraints and decision variables given in the title have been replaced into the model, and the lift coefficient and air density have been regarded as unchanged[9] at the moment, and the launch strategy [10] that the UAV needs to execute under the constraints has been obtained.

The radius  $r = 0.08m$  and mass  $m = 5kg$  of the spherical explosive are known. And the flying speed of the UAV is  $v_1 = 300km/h$ , the launching speed is  $v_2 = 600km/h$ , and the total speed is  $v = v_1 + v_2 = 900km/h$ .

It is known that the position of the aircraft before starting

the dive motion is the vertical distance  $H_{original} = 800m$  from the ground and the horizontal distance  $L_{original} = 10000m$  from the target. And there are constraints:

$$\begin{cases} H_{bow} \geq 300m \\ 1000m \leq L \leq 3000m \\ v_{wind} = 6m/s \end{cases} \quad (10)$$

To satisfy this constraint, the maximum descent height  $H_{max} = H_{original} - H_{bow} = 500m$  of the UAV during the dive; The diving Angle of UAV in the process of diving is expressed as follows:

$$\theta = \arcsin \frac{H_{max}}{\sqrt{H_{max}^2 + L_{original}^2} - L} \quad (11)$$

The flight time of the ball explosive in the air:

$$t_{down} = \frac{-v_z + \sqrt{v_z^2 + 2aH_{bow}}}{a} \quad (12)$$

Given the time it takes for a ball explosive to hit the ground for the two dive angles, you only need to find the horizontal distance it travels for the three wind directions.

① In the case of downwind, the horizontal velocity of the explosive is:

$$v_x' = v_{wind} + v_x \quad (13)$$

Therefore, according to the above model substitution operation:

$$L_{level} = v_x' t_{down} - \frac{1}{2} a_1 t_{down}^2 \quad (14)$$

And finally obtain the distance between the UAV and the target point when the explosives are launched:

$$L = \sqrt[2]{H_{bow}^2 + L_{level}^2} \quad (15)$$

In order to make the explosive hit the target, the launch position of the aircraft  $1000m \leq L \leq 3000m$  and  $H_{bow} \geq 300m$ . Then the matlab numerical simulation solution is used to finally determine the UAV in the wind at the height from

the ground  $500.001138m$ , at the horizontal distance  $1000.726019m$  from the target, as the dive Angle  $\theta = 26.548474^\circ$  of the launch strategy. At this time, the straight-line distance  $L = 1118.6834m$  between the UAV and the target point meets the constraints.

② In the case of headwind, the horizontal velocity of the explosive is:

$$v_x'' = v_x - v_{wind} \quad (16)$$

Substitute the model in ① as follows.

$$\begin{cases} L_{level} = v_x'' t_{down} - \frac{1}{2} a_1 t_{down}^2 \\ L = \sqrt[2]{H_{bow}^2 + L_{level}^2} \end{cases} \quad (17)$$

Similarly, it can be obtained that the height  $500.001138m$  of the UAV from the ground and the distance  $1000.686864m$  from the target horizontal plane under the headwind condition are considered  $26.549370^\circ$  as the launching strategy of the dive Angle. At this time, the straight-line distance  $L = 1118.6484m$  between the UAV and the target point meets the constraints.

③ In the case of vertical wind, the horizontal speed of the explosive is:

$$\begin{cases} v_x''' = v_z \\ v_y = v_{wind} \end{cases} \quad (18)$$

According to the above model, the trajectory of the spherical explosive at this time is a three-dimensional graph.

$$\begin{cases} L_{level} = \sqrt[2]{\left(v_x' t_{down} - \frac{1}{2} a_1 t_{down}^2\right)^2 + \left(v_y t_{down}\right)^2} \\ L = \sqrt[2]{H_{bow}^2 + L_{level}^2} \end{cases} \quad (19)$$

Similarly, it can be obtained that the height of the UAV from the ground under the condition of vertical wind is  $500.001138m$ , and the distance from the horizontal plane of the target is  $1001.3134m$ , which is the launching strategy of the dive Angle  $\theta = 26.548922^\circ$ . At this time, the straight-line distance  $L = 1119.2089m$  between the UAV and the target point meets the constraint conditions. The details are shown in Table 2.

**Table 2.** UAV launch strategies for three wind directions

	H	L	Dive Angle $\theta$	Linear distance L
Tailwind	500.001138m	1000.726019m	26.548474°	1118.6834m
Headwind	500.001138m	1000.686864m	26.549370°	1118.6484m
Vertical wind	500.001138m	1001.3134m	26.548922°	1119.2089m

## 4. Conclusion

By combining the air resistance model in the aerodynamic model with Newton's second law, an efficient solution to the ball projection problem at low speed is constructed.

When the aircraft is thrown horizontally, the sphere motion is decomposed into horizontal and vertical directions, and the velocity is  $v_x, v_z$ . The horizontal initial velocity of the ball is

the cruise speed of the aircraft  $83.3m/s$ . In the vertical direction, the ball moves in a linear motion with variable acceleration under the action of air resistance and universal gravitation, and the air resistance increases with the falling speed of the ball. The landing time of the sphere is  $t=8.129$  seconds. After that, no matter the direction of the wind, the movement time of the ball is constant. By simplifying the model, the horizontal wind speed in the horizontal direction

is directly superimposed on the sphere, and the horizontal speed of the sphere under the three wind directions is determined as:  $v_x = 88.3m/s$ ,  $v_x'' = 83.3m/s$ ,  $v_x''' = 78.3m/s$ . By solving the dynamic model, the horizontal flight distance of the sphere under the three wind directions is obtained:  $571.3011m$ ,  $517.8954m$ ,  $544.8736m$ . The delivery distance of the aircraft is calculated by the Euclidean distance:  $717.7907m$ ,  $636.5007m$ ,  $677.1457m$ .

And through numerical iteration, the dive angles of the aircraft under the three wind directions are respectively  $26.5485^\circ$ ,  $26.5494^\circ$ ,  $26.5489^\circ$ , and the position of the aircraft when launching is  $(500,1000.726)$ ,  $(500,1000.687)$  and  $(500,1001.313)$ , and the straight-line distance to the target is:  $1118.6834m$ ,  $1118.6484m$ ,  $1119.2089m$ . Considering the accuracy of the above model for solving the specified constraints, the model can be extended to obtain the UAV fixed-point delivery model suitable for complex and changeable situations.

This model is extended as a core special case, which can be extended after the introduction of other factors, and has good compatibility and universality.

## References

- [1] Zang Qian. Research and Implementation of UAV precise Point Control Based on Multi-information Fusion [D]. Shenyang University of Aeronautics and Astronautics, 2022.
- [2] Ning Xin. Research on Control Method of Quad-rotor UAV [D]. Harbin Institute of Technology, 2018.
- [3] Wu Qingchun, Qian Yangde. [3] WU Q C, QIAN Y D. Research on the cause and Quantitative Analysis of Air Resistance of moving Objects by Air resistance Coefficient measuring instrument [J]. College Physics, 2017, 4 (5) : 27-32.
- [4] Zhao Bingyan, Liu Weijun, Chen Zonghua. Wind speed cases swash cast ball flight trajectory analysis [J]. Journal of Yulin Normal University, 2020, 9 (3) : 36-42.
- [5] Gong Yongshou, Shen Yijun, Li Chunxu. Uav precision and toss life buoy scheme research [J]. Journal of Pearl River Water, 2020 (22) : 38-40.
- [6] Wang Zhenxin, Su Wenbin, Shi Yanpeng. To explore the influence of the air resistance of sphere stant cast movement [J]. Science and Technology, the Wind, 2023, No. 520 (8) : 163-165.
- [7] Liu Hao. Exploring the real motion process of falling objects from high altitude [J]. Hunan Middle School Physics, 2020, 35(06): 31-32+49.
- [8] Huang Heji, Chen Shijie, Ma Junling et al. Research on Mathematical model of aircraft landing process [J]. Science Consulting (Science and Technology Management), 2022, No.781 (04):35-37.
- [9] Wang Xiaolei, Zhong Yuming. Analysis of drifting and Landing process Based on aerodynamic Parameters [J]. Journal of Civil Aviation, 2022, 6(01):73-76+84.
- [10] Si Shoukui, Sun Xijing, Mathematical Modeling Algorithm and Application, Beijing: National Defense Industry Press, 2021.4. page416.