

# Optimization of Endurance Performance for Quadrotor Unmanned Aerial Vehicles Driven by a Hybrid System of Solar Photovoltaic Cells and Energy Storage Batteries

Zhenpeng Lai \*

Maynooth International Engineering College, Fuzhou University, Fuzhou, Fujian, 350100, China

\* Corresponding author Email: Zhenpeng.LAI@outlook.com

**Abstract:** The potential applications of unmanned aerial vehicles (UAVs) are vast and exciting, yet their scope could be significantly expanded if their flight endurance could be extended. The primary objective of this study is to design a hybrid power system combining solar energy and lithium batteries to enhance the endurance and energy management efficiency of unmanned aerial vehicles (UAVs). Through comparative analysis of series, parallel, and hybrid power systems, a parallel hybrid power system was chosen as the power solution for UAVs. In this paper, we detail the selection process for solar panels and lithium batteries and elucidate the design of a solar endurance enhancement system, including the application of anti-backflow and voltage stabilization modules. Additionally, we propose an energy management strategy based on finite state machines, which ensures efficient and stable operation of the system through real-time monitoring and dynamic adjustment. The methodology of this study provides an innovative and practical framework for the design and implementation of solar and energy storage battery hybrid energy management systems for UAVs.

**Keywords:** UAVs; Hybrid Power Systems; Solar Energy; Lithium Batteries; Energy.

## 1. Introduction

With the rapid development of UAV technology, its applications in military, commercial, and scientific research fields are becoming increasingly widespread. Yet, to further broaden their scope, it's essential to extend the flight endurance of unmanned aerial vehicles (UAVs) [1]. Research has revealed that both electric- and fossil fuel-powered UAVs lack sufficient flying endurance for diverse tasks. Endurance and energy management efficiency of UAVs are critical factors limiting their performance. Traditional power systems, due to limitations in energy density and conversion efficiency, struggle to meet the demands of long-duration, high-efficiency flights. Consequently, there has been a growing emphasis on the development of efficient hybrid power systems for UAVs, particularly those integrating solar energy with battery-powered systems. Such developments are crucial for the future advancement of UAV technology [2].

This paper proposes a design for a hybrid power system combining solar energy and lithium batteries to enhance the endurance and energy management efficiency of UAVs. Through comparative analysis of different hybrid power systems, a parallel hybrid power system was selected as the power solution for UAVs. Leveraging the advantages of solar panels and lithium batteries, the system achieves efficient energy utilization and flexible power regulation through a parallel structure. Additionally, we designed a solar endurance enhancement system, further improving the endurance and stability of the system through the application of voltage stabilization and anti-backflow modules.

Furthermore, we propose an energy management strategy based on finite state machines to ensure efficient and stable operation of the system. By defining clear states, state transition rules, and real-time monitoring and adjustment, we effectively manage the energy flow of the system, ensuring efficient and stable operation of UAVs under various flight

conditions. This research provides an innovative and practical framework for the design and implementation of solar and energy storage battery hybrid energy management systems for UAVs, and serves as a reference for the design of hybrid power systems in other fields.

## 2. System Design

### 2.1. Hybrid Power System Selection

When selecting the power system for unmanned aerial vehicles (UAVs), hybrid power systems can be categorized into series, parallel, and series-parallel hybrid systems based on their connection methods.

#### 2.1.1. Series Hybrid Power System:

In a series hybrid power system, the solar panels, generator, and drive motor are connected in series. Solar panels convert solar energy into electricity, which is then converted into mechanical energy by the generator for the drive motor. This system offers high flexibility and is suitable for low-speed, high-torque environments. However, the efficiency is relatively low due to multiple energy conversions, and the large power requirements of the generator and drive motor increase system weight and volume.

#### 2.1.2. Parallel Hybrid Power System:

In a parallel hybrid power system, the solar panels are directly coupled with the engine/generator. The engine/generator is mechanically coupled with the drive motor, but maintaining the engine in its optimal operating range can be challenging. This system offers advantages such as smaller size and power requirements for the engine and drive motor, as well as higher energy conversion efficiency. However, controlling the engine within its optimal operating range poses difficulties.

#### 2.1.3. Series-Parallel Hybrid Power System:

This system combines the advantages of series and parallel systems, including solar panels, energy storage batteries,

engine/generator, and drive motor. The system can operate the engine and drive motor simultaneously or separately based on requirements. However, the system's structure is complex, requires significant space, and necessitates sophisticated control strategies [3].

Considering weight and space constraints, the series-parallel hybrid power system is initially excluded. For UAV power system selection, the parallel hybrid power system is preferred. The series hybrid power system faces challenges such as multiple energy conversions, increased weight and volume, and limited power control, which are not suitable for UAV power requirements. In contrast, the parallel hybrid power system simplifies energy conversion paths, improves energy utilization efficiency, and offers flexible power control, making it more suitable to meet the performance and operational needs of UAVs [3].

## 2.2. Design and Implementation of Solar and Lithium Battery Hybrid Power System

### 2.2.1. Solar Panel Selection

The working principle of solar panels is based on the photovoltaic effect, where incident light on semiconductor materials generates electron-hole pairs. By applying electrodes to both ends of the semiconductor, a closed circuit is formed, resulting in electric current flow. When the PN junction is illuminated, it generates photogenerated current and voltage, thereby forming the output characteristics of solar panels. The key to solar power generation lies in solar panels, with one important indicator being the photovoltaic conversion efficiency. Currently, monocrystalline silicon solar panels have a photovoltaic conversion efficiency of

around 15% [4]. This paper selects the Sunpower C60 monocrystalline silicon solar panel for power supply. Sunpower solar panels have the following characteristics and advantages:

- Lightweight and versatile, suitable for various applications such as solar backpacks, solar chargers, and foldable solar panels, making them easy to carry and use.
- Sunpower solar panels have a power range from 1W to 300W, making them convenient for design and OEM use.
- The use of Sunpower solar cells can achieve a conversion efficiency of up to 23%, with a back-contact design ensuring stability and durability of power output.
- Sunpower solar cells are encapsulated with high-performance scratch-resistant PET/EVA polyester film, characterized by high gloss, UV resistance, and aesthetics.
- Efficient PET and corrosion-resistant EVA materials effectively protect Sunpower solar panels, ensuring stable performance and efficient charging effects.
- Sunpower solar panels exhibit excellent low-light performance, with high conversion efficiency, outperforming other monocrystalline silicon panels under similar conditions [5].

In summary, Sunpower solar panels provide a reliable energy source for solar power systems with their efficient performance and stable characteristics.

### 2.2.2. Parallel Hybrid Power System:

As a power source that can both store energy as an energy storage unit and release energy outward as an energy output unit, batteries come in multiple types, with their performance compared in Table 1.

**Table 1.** Performance Comparison of Different Types of Batteries

performance metrics	Number of cycles	Energy density (Wh/kg)	power density(W/kg)
(Lead-Acid)	500-2000	20-50	150-300
(Ni-Cd)	600-3000	40-60	80-350
(Ni-MH)	600-2000	50-80	80-300
(Ni-Zn)	600-1200	55-75	150-300
(Li-Ion)	>1000	90-200	200-400

According to Table 1, it is evident that lithium-ion batteries have an energy density upper limit that is more than twice that of other types of batteries. Additionally, lithium-ion batteries also exhibit a greater power density. Therefore, compared to other types of batteries, they are highly suitable for providing the necessary electrical energy for unmanned aerial vehicles (UAVs) during flight [6].

### 2.3. Solar Endurance Enhancement System

The solar endurance enhancement system mainly consists

of solar panels, lithium batteries, voltage regulation modules, and anti-backflow modules, as illustrated in Figure 2. The lithium battery provides the necessary electrical energy for the UAV to operate normally during flight, while the solar panels convert solar radiation into electricity when sunlight is sufficient to supply a portion of the energy required by the UAV [7].

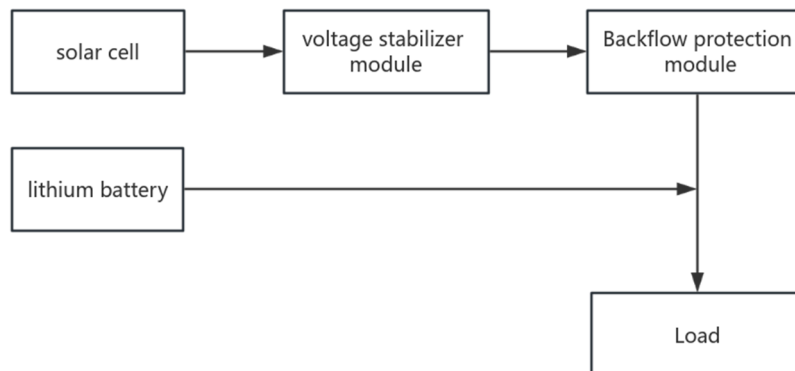

**Figure 1.** Solar Endurance Enhancement System

### 2.3.1. Anti-Backflow Module

The anti-backflow module (rectifier module) is designed to prevent unequal voltages at the terminals of the parallel-connected batteries from causing circuit backflow, thus avoiding battery internal consumption and waste of battery energy.

### 2.3.2. Voltage Regulation Module

Due to the principle and characteristics of solar panel power generation, the output voltage at the solar panel's output terminal varies with the intensity of sunlight radiation. Therefore, voltage regulation is necessary. The role of the voltage regulation module is to stabilize the voltage output at the output terminal of the solar panel, ensuring that the output voltage remains stable at the set value regardless of fluctuations in the input voltage within the specified range. The voltage regulation circuit adopts the LTC3780 chip to stabilize the input voltage. The output voltage can remain stable regardless of whether the input voltage is higher than, equal to, or lower than the output voltage [4].

Twelve solar panels are connected in a series of four sets, each set comprising three panels in parallel. These panels, along with the voltage regulation module and anti-backflow module, are connected in series with lithium batteries, supplying power to the UAV system together in parallel. This configuration aims to reduce the consumption of lithium battery power. The solar panels are connected in series with the voltage regulation module and rectifier diodes, then in parallel with the lithium batteries, jointly providing power to the UAV. The electrical system circuit is depicted in Figure 3 [7]. The series-parallel connection of four sets of panels, along with the voltage regulation module, supplies power to the UAV system in parallel with the lithium batteries, aiming to reduce lithium battery consumption [4].

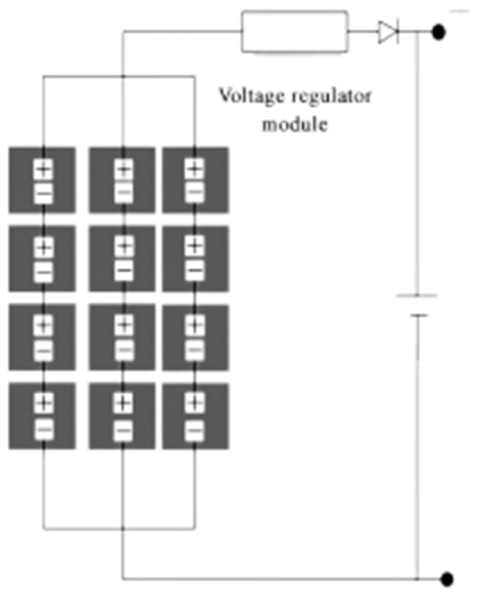

Figure 2. Electrical System Circuit

## 3. Energy Management Strategy

Finite state machine is one of the widely adopted control strategies, which utilizes pre-defined conditions (if-then statements) to manage state transitions of controlled objects in a simple and reliable manner. This method requires minimal computation for managing complex systems,

supports online implementation, and has been successfully applied in fields such as solar-hybrid power systems [3].

For the hybrid power system of unmanned aerial vehicles (UAVs), its operational states can typically be classified into several modes including engine-only propulsion, hybrid propulsion, and energy battery charging. In this system, this paper elaborately designs a hybrid energy management system integrating solar and energy storage batteries, including state definitions, state transition rules, and energy management strategies, aiming to achieve efficient and stable system operation.

The system states are defined as follows: solar charging state (State 0), energy storage battery discharge state (State 1), energy storage battery charging state (State 2), and normal operating state (State 3).

In State 0, the system utilizes solar photovoltaic panels to directly charge the energy storage battery. The system continuously monitors solar power generation and charging rates to ensure effective charging processes.

When solar power generation is insufficient to meet the power demand, the system transitions to State 1, extracting energy from the energy storage battery to supply the demand. In State 1, the system continuously monitors the battery's state of charge and discharge rate to prevent over-discharge and battery damage.

In State 2, the system charges the energy storage battery based on solar power generation or the availability of an external power source. If solar power generation is insufficient to meet the demand or an external power source is available, the system initiates the charging process. The system dynamically adjusts the charging power to fully utilize available resources while ensuring stability. During the charging process, the system continuously monitors solar power generation, the availability of an external power source, and the charging status of the energy storage battery to promptly adjust the charging strategy and ensure sufficient energy supply when needed.

Once solar power generation is adequate or the power demand is low, the system switches to State 3, entering the normal operating state. In this state, the system utilizes both solar power and energy storage batteries to supply the demand. The system continuously monitors solar power generation, the state of the energy storage battery, and the power demand, dynamically adjusting the energy supply to ensure stable system operation and meet the UAV's requirements.

By defining clear state definitions and transition rules, as well as implementing real-time monitoring and adjustment in the energy management strategy, the proposed method offers a feasible solution for the design and implementation of a hybrid energy management system integrating solar and energy storage batteries, with promising prospects for practical application.

## 4. Conclusion

This study has designed a hybrid power system integrating solar and lithium batteries aimed at enhancing the endurance and energy management efficiency of unmanned aerial vehicles (UAVs). Through comparative analysis of series, parallel, and series-parallel hybrid power systems, we selected the parallel hybrid power system as the power solution for UAVs. This system leverages the advantages of solar panels and lithium batteries to achieve efficient energy utilization and flexible power regulation through a parallel

structure.

In terms of the selection of solar panels and lithium batteries, we chose the Sunpower C60 monocrystalline silicon solar panels and lithium-ion batteries with high conversion efficiency and stability to ensure the reliability and durability of the system performance.

To further improve the endurance and stability of the system, we designed a solar endurance enhancement system, including the application of anti-backflow modules and voltage regulation modules. These modules effectively manage energy flow, ensuring efficient and stable operation of the system under various flight conditions.

Finally, we proposed an energy management strategy based on finite state machines. By defining clear state definitions, state transition rules, and real-time monitoring and adjustment, we effectively managed the energy flow of the system, ensuring efficient and stable operation of the UAV under various flight conditions.

In conclusion, this study provides an innovative and practical framework for the design and implementation of a hybrid energy management system integrating solar and energy storage batteries for UAVs. It is expected to bring new ideas and solutions to energy management in the field of UAVs.

## References

- [1] Chu, Y., Ho, C., Lee, Y., & Li, B. (2021). Development of a Solar-Powered Unmanned Aerial Vehicle for Extended Flight Endurance. *Drones*, 5(2): 44.
- [2] Rajendran, P., & Smith, H. (2018). Development of design methodology for a small solar-powered unmanned aerial vehicle. *International Journal of Aerospace Engineering*, 2018.
- [3] Chen, Z. (2022). Energy management of parallel hybrid power unmanned aerial vehicle. Thesis of South China University of Technology, 72.
- [4] Xu, P. (2017). Design and implementation of solar-powered endurance system for unmanned aerial vehicles. *Digital Design*, 06: 90-91.
- [5] Kan, W. (2023). Research on control strategy of multi-power source switching in unmanned aerial vehicle power system. Thesis of Dalian Jiaotong University, 110.
- [6] Cheng, Z. (2022). Research on hybrid power system of quadrotor unmanned aerial vehicle with fuel cells. Thesis of Jilin University, 102.
- [7] Xu, W., Chen, K., Zhang, M., et al. (2018). Enhancement scheme of endurance for solar-powered agricultural unmanned aerial vehicles. *China Agricultural Science and Technology Herald*, 11: 62-68.