

VR/AR-based Wind Turbine Gearbox Maintenance Training System

Qiancheng Tang^{1, a}, Yang Tang^{1, b}

¹Department of Mechanical Engineering, Southwest Petroleum University, Chengdu 610500, China

^asugarlion1018@163.com, ^b1101540210@qq.com

Abstract: In view of the remote geographical location of wind farms, complex environmental conditions, especially the complex structure of gearboxes in wind turbines, which leads to the difficulty of equipment maintenance and troubleshooting, combined with the rapidly developing virtual reality technology (VR) and augmented reality technology (AR), a VR/AR wind power gearbox maintenance training system is designed to solve the above problems. The system includes a maintenance training system for gearbox maintenance, disassembly and assembly learning, exercises, working principle display, detailed data query of parts and AR model auxiliary inspection, to help maintenance personnel better complete the maintenance work of gearbox.

Keywords: Wind turbine gearbox, virtual reality technology, augmented reality technology, Unity3D.

1. Introduction

As a key area for the development of global renewable energy, wind power has made remarkable technological progress in recent years, and its installed capacity has been growing, making it occupy an increasingly important position in the global energy structure. However, because wind turbines are often installed in harsh environments, they often face a series of failure challenges. In particular, the gearbox is a complex and vital mechanical component in wind turbines. The gears and bearings inside the gearbox are subject to high loads and high speeds, which can lead to wear and tear[1]. In addition, although control system and electrical system failures are common and quick to recover from, the complex structure of the gearbox makes the troubleshooting and repair process time-consuming and expensive.

The application of virtual reality technology originated in the 1990s. NASA utilized VR technology to create virtual astronauts for scientific exploration at NASA's Planetary Data System (PDS) Earth Science Node[2], aiding the study of Mars' environment and evolution. Since then, it has gradually been applied in the industrial sector. Currently, in the industrial field, many scholars have designed related training systems using the immersive experience provided by virtual reality technology. Renowned German automotive brands such as Volkswagen, BMW, and Mercedes-Benz have established maintenance training systems using virtual reality technology for car repairs[3]. To address the limitations of on-site mechanical component maintenance training due to spatial and temporal factors, Li Jirui and others designed a virtual maintenance training system for transmissions, significantly improving the proficiency of maintenance personnel in disassembly and assembly processes[4].

In recent years, with the rise of augmented reality (AR) technology, it has also been widely applied in the industrial field. Augmented reality technology can combine virtual information with real-world scenes, simulating and integrating virtual data into the real world so that both sets of information complement each other. This results in an "enhanced" perception of the real world[5]. Currently, Liu Shichan has utilized HoloLens devices to design an

automotive maintenance assistance system, providing guidance and support for car repairs[6]. Sun Guichuan and others have designed and developed a feature-based assembly prototype system within a networked AR environment to facilitate applications in the field of mechanical assembly[7]. Li Dayong and his team have addressed the issues of insufficient experience among substation equipment inspectors and low efficiency in handling on-site defects by using AR technology to enable expert remote assistance and access to knowledge databases. This significantly reduces the likelihood of safety incidents[8].

At present, virtual reality technology and augmented reality technology are developing rapidly in the industrial field. The maintenance of machinery and equipment in the industrial field has realized a variety of applications such as remote operation and maintenance, virtual disassembly and assembly, data analysis and prediction. At the same time, the development of virtual reality technology and augmented reality technology also promotes the intelligence and digitalization of mechanical products, serving human production and life in a more efficient, safe and accurate way.

In this paper, a maintenance training system for wind turbine gearbox maintenance and model-assisted inspection is designed, which combines VR and AR technology, as well as Internet instant messaging and database technology, to help staff master the repair, disassembly and maintenance of wind turbine gearbox, and improve the quality and efficiency of maintenance work.

2. Structure and Principle of Wind Power Gearbox

The main functions of a wind turbine gearbox are reflected in power transmission and speed regulation. The gearbox transfers the power generated by the wind turbine rotor to the generator and increases the rotational speed to meet the generator's input speed requirements. Since the rotational speed of the rotor is typically low, the gearbox adjusts the speed increase ratio to convert the rotor's low-speed, high-torque motion into a high-speed, low-torque output to ensure the system operates smoothly.

Taking a gearbox composed of a two-stage planetary gear system and a parallel shaft system as an example, as shown in

Figure 1.

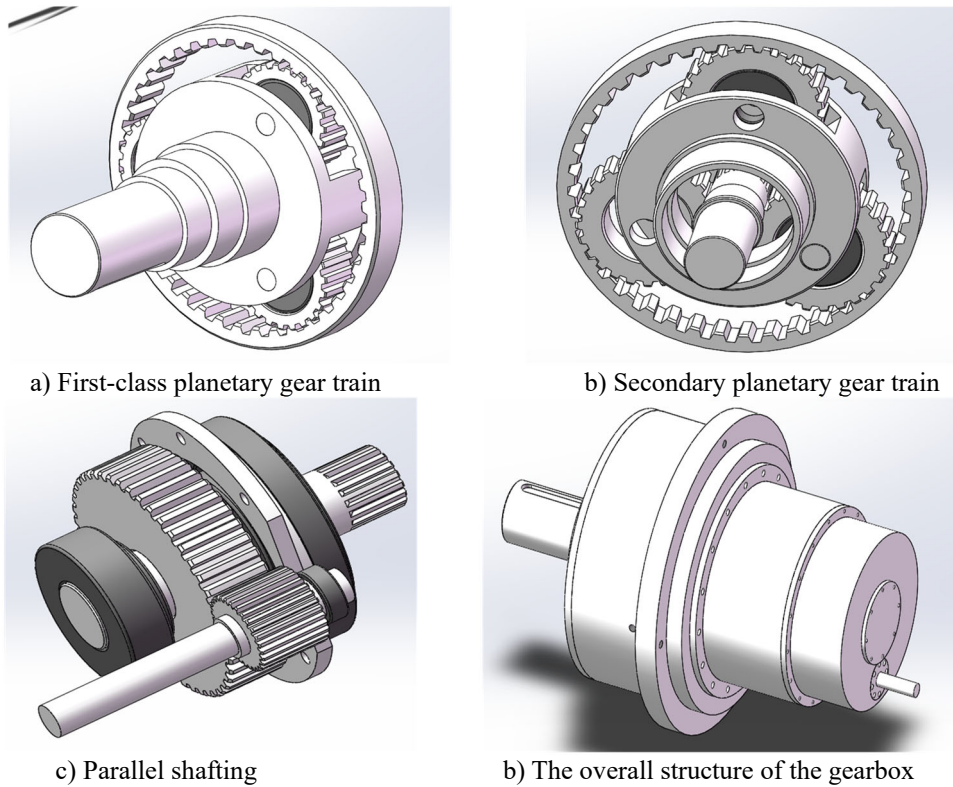

Figure 1. Schematic diagram of wind power gearbox structure

3. System Design Scheme

3.1. System framework design

The overall architecture of the system is illustrated in Figure 2. It is broadly divided into the client side, application layer, model layer, service layer, and data storage.

The client side is mainly divided into PC and mobile platforms, which respectively host the VR assembly and disassembly training program and the AR maintenance training program, both developed using Unity3D.

The application layer consists of various functional modules implemented by the system, primarily categorized into VR assembly and disassembly training and AR maintenance training. The VR assembly and disassembly training part includes document and video introductions, simulation operation, manual assembly and disassembly, automatic assembly and disassembly with parts display, maintenance manuals, and a remote assistance receiver. The AR maintenance training part includes a wind turbine gearbox information management module and a maintenance steps module.

The model layer comprises the interactive logic between the model and data, as well as dynamic presentation rules for other scene function interactions. This includes simulation of wind turbine gearbox operation, logic for free assembly and disassembly, automatic assembly and disassembly paths, video playback, collision detection logic for models, disassembly animation design, and model-assisted detection logic. Models utilize data services from the service layer to call and update data to complete the display of various dynamic logics.

The service layer is primarily responsible for network

services and data transmission necessary for remote assistance, as well as data services for calling, inserting, updating, and deleting relevant data from the database.

Data storage consists of an SQL Server database for storing equipment data.

3.2. System Development Process

The development process for the wind turbine gearbox maintenance training system is outlined in Table 1. The first step involves precise modeling of gearbox components in SolidWorks, taking into account actual working relationships. Once the modeling is complete, the models are exported in STEP format to 3ds Max for optimization. This step involves simplifying the models and exporting them as FBX files to facilitate rendering and interactive design in Unity3D.

In Unity3D, the system uses components and C# programming to implement human-computer interaction and control of component movements within the VR training system. The Dotween plugin is utilized for managing animation logic.

For the AR training system, Vuforia is employed to achieve augmented reality by combining virtual elements with the real world. Animator is used for creating assembly and disassembly animations. C# programming is further used to achieve database interactions with SQL Server, and WebRTC technology is employed to provide remote assistance capabilities.

The user interface for the human-computer interaction is designed using Unity3D's UGUI system. Finally, the application is compiled and deployed to both PC and mobile platforms, ensuring a comprehensive and platform-compatible wind turbine gearbox training system.

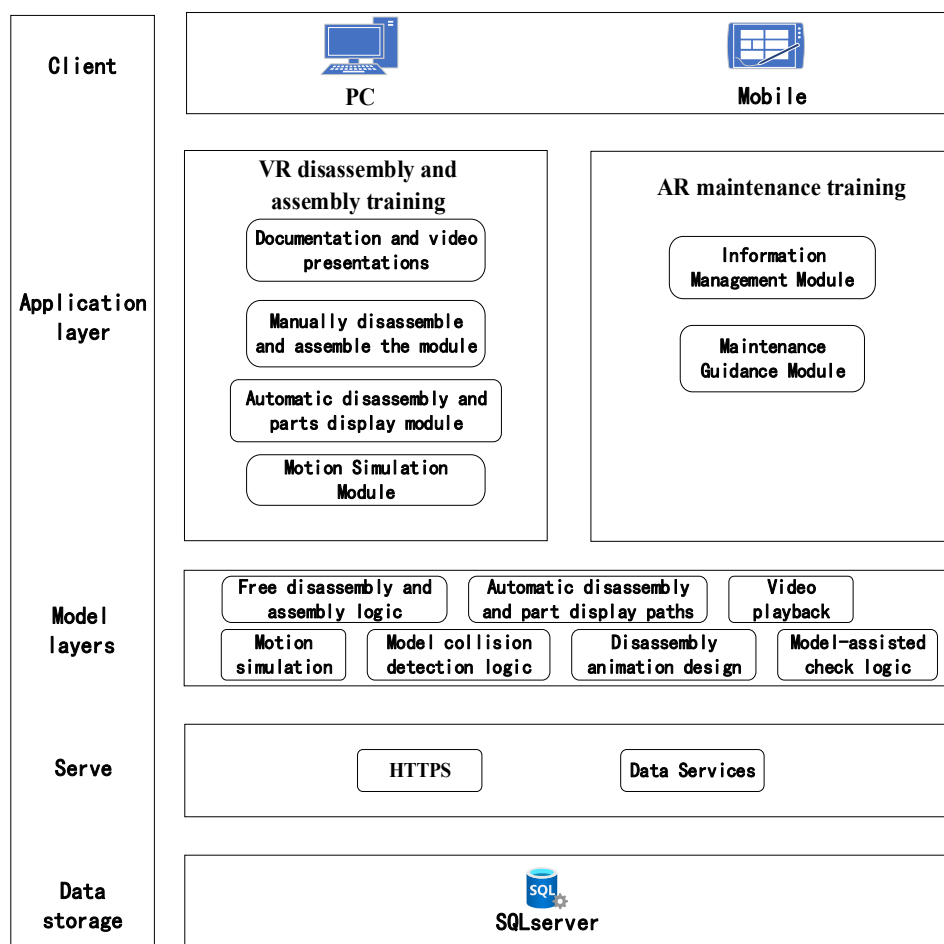

Figure 2. Overall system architecture

Table 1. Training system development flowchart

Development sequence	Software	Task fulfillment	format
1	SolidWorks	Build a 3D model	Step
2	3DMAX	Model optimization	fbx
3	Visual Studio	Write C# control scripts	.c
4	SQLserver	Build a database of part information	.db
5	Unity3D	Create the UI interface of the training system, add simulation materials, build virtual scenes, make animations to show the principle, publish, etc	.apk/exe

4. System Function Development and Design

The wind turbine gearbox maintenance training system includes several functional modules, such as disassembly and assembly learning, practice sessions, maintenance manual lookup, operational principle understanding and maintenance guidance, as well as a remote assistance module. After importing the gearbox 3D models, materials, and component information database into the development platform, the development process involves establishing the navigation links between various functional modules, designing the UI display formats, implementing the disassembly and assembly operation methods, and writing control statements in C#.

4.1. Running the Simulation

The simulation module operates based on the transmission relationships within the gearbox's internal gear systems. By inputting the blade speed and the transmission ratio of each gear stage, the module calculates the speed increase for each gear stage, thereby completing the gearbox transmission simulation. Figure 3 illustrates the gearbox operation simulation scene. On the left side is the parameter input interface, which is used for entering the relevant parameters. On the right side, you can see the gearbox model and the speed display box. The upper section shows the speed of each gear stage once the relevant parameters have been entered. The lower section presents the operational status of the gearbox.

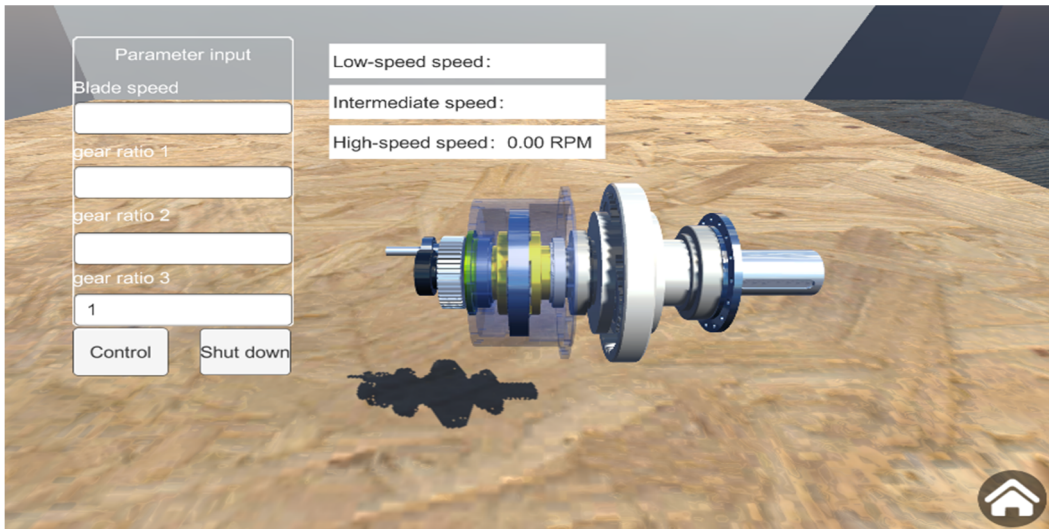

Figure 3. Running the simulation

4.2. Disassembly and assembly function

The assembly and disassembly function consists of two parts: manual assembly and disassembly, and automatic assembly and disassembly along with component information display. Through guided steps for assembling and disassembling the gearbox, users can engage in interactive practice and learning, conduct inquiries about key component information, and view principle demonstration videos. This function provides a detailed presentation of the assembly relationships between various components of the gearbox, as well as the assembly process and techniques involved.

4.2.1. Manual disassembly and assembly

The manual assembly and disassembly module is implemented using the principles of ray detection and a

hybrid bounding box collision detection algorithm. The gearbox model is equipped with bounding boxes, which are mainly divided into two types: Axis-Aligned Bounding Boxes (AABB) and capsule bounding boxes. The gearbox model is divided into three parts based on spatial regions: the first-stage planetary gear system, the second-stage planetary gear system, and the parallel shaft system. Each part is externally surrounded by an AABB box, and the internal gears and shafts are enclosed separately by AABB boxes and capsule bodies. When collisions occur between bounding boxes, the system first performs bounding detection between the upper-level AABB boxes and then detects the internal AABB boxes and capsule bounding boxes. As shown in Figure 4, this forms a hierarchical hybrid bounding box tree.

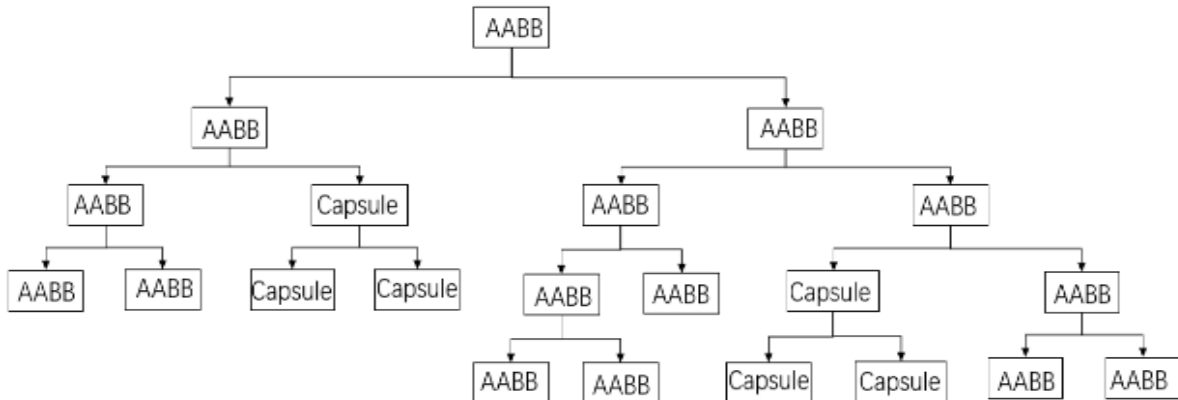

Figure 4. Hierarchy encloses the box tree

Figure 5 shows the manual disassembly and assembly function, and the user can use the keyboard and mouse to interact with the model in real time, and disassemble and assemble the part model in sequence according to the disassembly sequence.

4.2.2. Automatic disassembly and assembly and parts information display

The automatic assembly and disassembly and parts

information display scene is shown in Figure 6. The components of the gearbox are displayed in the assembly and disassembly order set by the algorithm. Users can control the method of assembly and disassembly of the gearbox components using the assembly and disassembly buttons located in the lower part of the scene interface, allowing for distributed or complete assembly and disassembly.

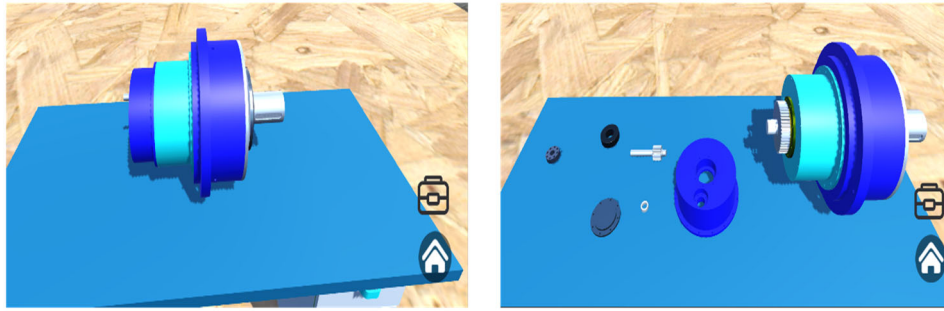

a. Before and after manual disassembly

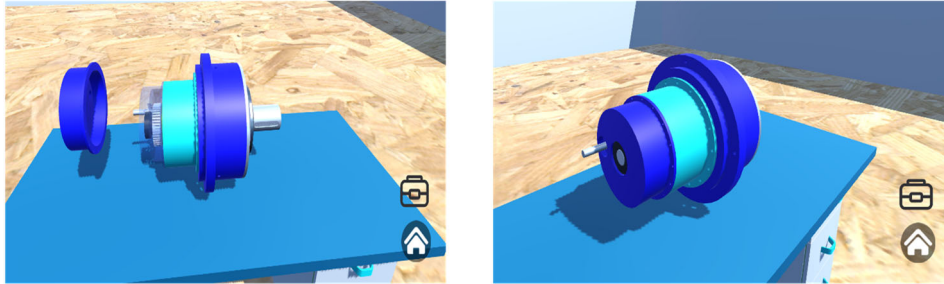

b. Before and after manual assembly

Figure 5. Manual disassembly and assembly

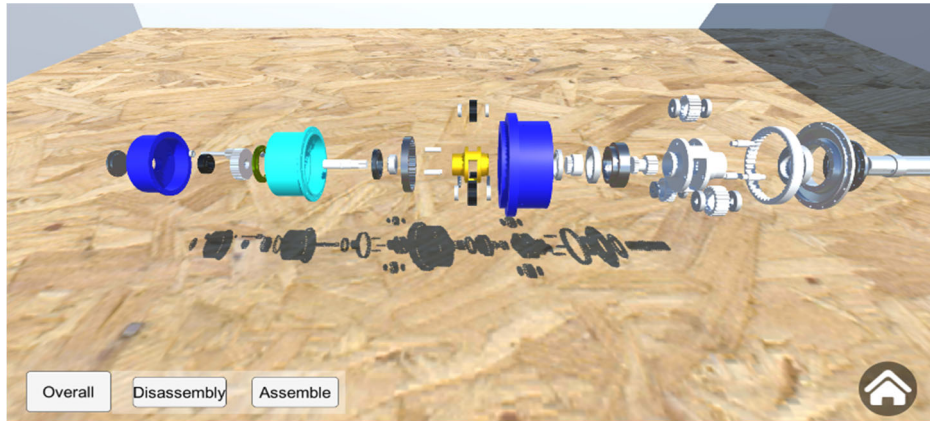

Figure 6. Automatic disassembly and assembly

The parts information display function is designed to present the data of the components. When a user clicks on a specific component, a UI interface pops up to display the

information data related to that part. Figure 7 shows the information data for the second-stage internal ring gear.

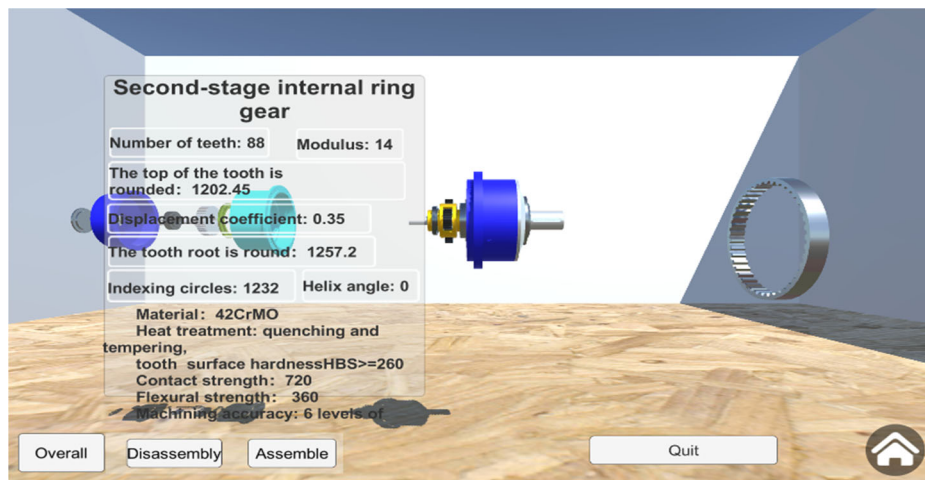

Figure 7. The second stage of the inner ring gear information display

4.3. Information Management

The maintenance of wind turbine gearboxes is a complex task that requires the collection and analysis of various data

to ensure long-term operation and efficiency. The information data related to the gearbox includes basic information about the gearbox, its operational status, temperature, and more. Multiple data tables are created in the SQL Server database to

separately store this information. Relevant C# code is written to connect to SQL Server and perform operations such as deletion, updating, and insertion of data. This approach

facilitates the management of gearbox information data. Figure 8 illustrates the information data processing workflow.

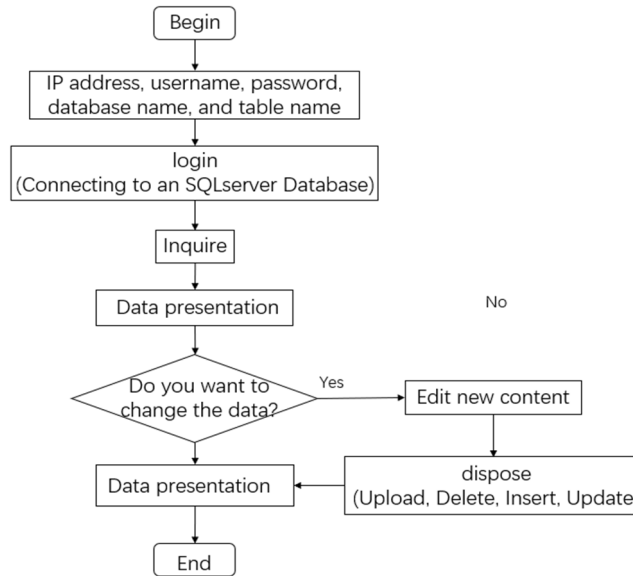

Figure 8. Information data processing processes

Figure 9 presents the information retrieval interface using gearbox basic information as an example. The upper section displays the basic information of the gearbox, while the lower

section includes the information processing methods and content editing fields.

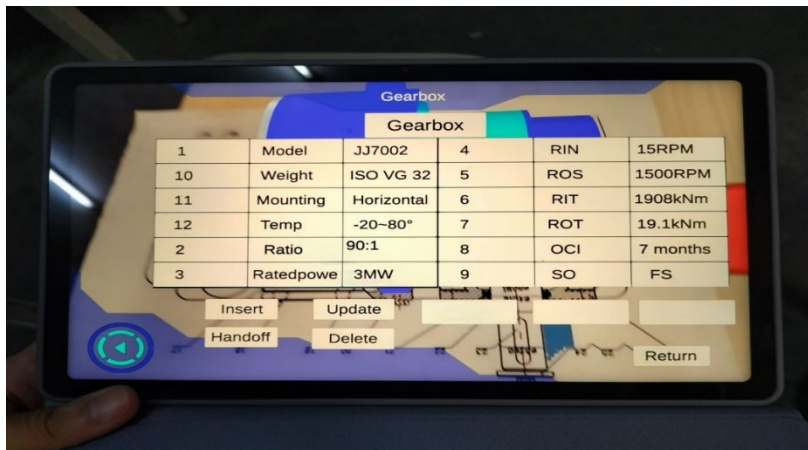

Figure 9. Basic information interface of gearbox

4.4. Maintenance Guidance

The maintenance guidance module is designed based on the maintenance process of the gearbox. It handles the maintenance process step by step, with each step displaying

maintenance methods through text content and showing the processing location using model animations. Additionally, the module employs models to simulate faults, as illustrated in Figure 10.

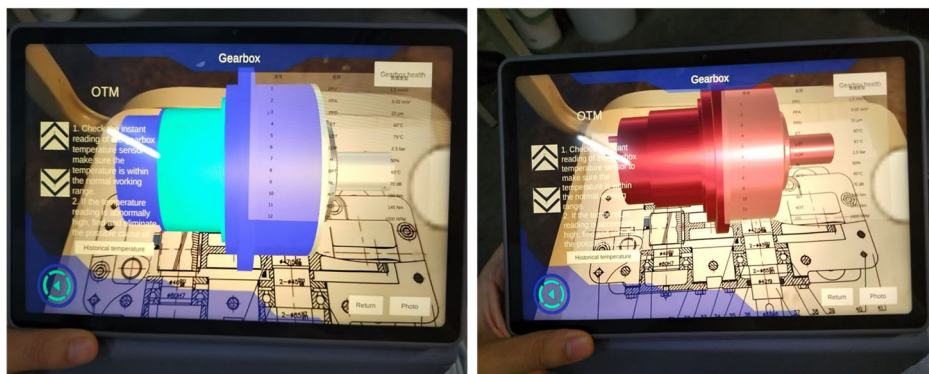

Figure 10. Simulation of over-temperature faults

4.5. System Deployment

Unity 3D supports deploying the developed system on various display platforms. To facilitate system promotion and meet users' learning needs, the designed and developed maintenance training system is deployed on Android mobile devices and PC platforms, as shown in Figure 11. This

provides users with convenient and flexible opportunities for learning maintenance knowledge. The wind turbine gearbox maintenance training system offers different learning experiences through various display methods, enabling users to quickly acquire the skills necessary for gearbox maintenance.

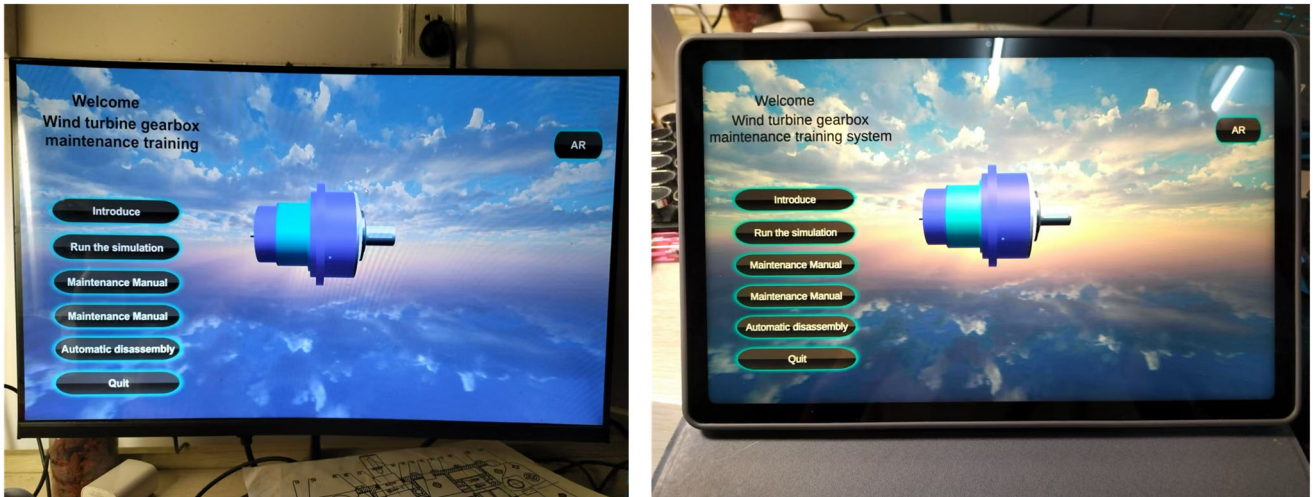

Figure 11. Wind turbine gearbox maintenance training system multi-port presentation

5. Conclusion

This article designs and develops a VR/AR-based wind turbine gearbox maintenance training system. It involves introducing the working principles of wind turbine gearboxes, motion simulation, assembly and disassembly training, maintenance training, and fault simulation training using database technology. By providing an immersive and interactive learning environment, the system significantly enhances training efficiency and safety compared to traditional methods. This not only shortens the learning curve but also brings higher operational standards and safety assurances to the industry.

References

- [1] AVIC Hi-Tech Intelligent Measurement and Control Co., Ltd. Current Status and Solutions for Offshore Wind Turbine Gearbox Maintenance [EB/OL].
- [2] Wang J, Bennett K J. A Virtual Reality Study on Santa Maria Crater on Mars[C]. 2013 IEEE Virtual Reality (VR), Lake Buena Vista, FL, USA, 2013: 105-106.
- [3] ZHOU J T, WANG H G, REN G Q, et al. Vehicle Design and Realization of Virtual Maintenance Training System[J]. *Advanced Materials Research*, 2013,94 (69):2449-2453.
- [4] Li Jirui, Zhao Yuejing. Research on Virtual Maintenance Training System for Gearboxes Based on VR[J]. *Print and Digital Media Technology Research*, 2024, (1): 129-136.
- [5] Hu Tianyu, Zhang Quanfeng, Shen Yongjie, et al. A Review of Augmented Reality Technology [J]. *Computer Knowledge and Technology*, 2017, 13 (34): 194-196.
- [6] Liu Shichan. Design of an Automobile Maintenance Assistance System Based on Augmented Reality Technology[J]. *Scientific and Technological Innovation*, 2022, (34): 58-61.
- [7] Sun Guichuan. Research on Feature-Based Network Augmented Reality Assembly System[D]. Beijing: Beijing University of Posts and Telecommunications, 2013.
- [8] Li Dayong, Yang Chang, Zhang Yongwu, et al. Design and Implementation of a Substation Intelligent Inspection System Based on AR Technology[J]. *Microcomputer Applications*, 2020, 36(08): 92-94+121.