

Study on the Optimal Allocation of Supercapacitor Capacity for Oil Drilling Winch Energy Recovery Microgrid System

You Yang*, Xiang Zhang, Kangyou Dou, Xudong Zhang, Yaru Dang, Pengfei Zang

School of Mechanical Engineering, Xi'an shiyou University, Xi'an 710000, China

*Corresponding author: You Yang (Email: 17502900869@163.com)

Abstract: The application of supercapacitor energy storage device in the microgrid system of ultra-deep well oil drilling rig can effectively recover the regenerative energy generated when the winch lowers the drilling tools. Firstly, a microgrid system model of super capacitor energy recovery for ultra-deep well oil drilling rigs was established; the theoretical recoverable energy during a complete operation of ultra-deep well drilling rigs was calculated; the economic efficiency of energy recovery was calculated by taking into consideration of a variety of economic factors, such as storage cost, pollutant emission reduction benefit, and storage loss, etc. was taken into account as the objective function of energy management and capacity allocation optimisation of super capacitor energy storage devices. Using genetic algorithm to solve the supercapacitor capacity configuration, when the well depth is 9000 m, the economic efficiency can reach 26.4% by using 5×377 supercapacitor combination; when the well depth is 12000 m, the economic efficiency can reach 32.7% by using 5×650 supercapacitor combination. It provides a corresponding reference to help improve the economic efficiency of the microgrid system for energy recovery of oil drilling rigs in ultra-deep wells.

Keywords: Ultra-deep well drilling rig; energy recovery; supercapacitor; economic efficiency; genetic algorithm.

1. Introduction

With the global energy shortage year by year, the exploitation of oil and gas resources develops to a deeper level, and the ultra-deep well oil drilling rig is an important equipment for the exploitation of deep oil and gas. In ultra-deep well oil drilling operations, the winch assumes a crucial function, which involves the lifting and lowering of drill columns and casing deployment operations. When the winch performs the lowering operation, the motor reverses under the positive effect of gravitational potential energy [1,2], generating regenerative electrical energy. In view of the huge energy-saving potential of this phenomenon, academia and industry have jointly explored and proposed an energy recovery microgrid system for oil rigs. This system can efficiently recover and recycle the large amount of regenerative power released during the reversal process of the winch motor, thus significantly improving the energy use efficiency and promoting the green and sustainable development of oil drilling operations [3].

Compared with other energy storage devices, the supercapacitor energy storage device has the advantages of high charging and discharging power, long cycle life, etc., which matches with the characteristics of the ultra-deep well oil drilling rig winch motor with high working power and frequent starting and stopping. This paper focuses on the optimisation of the capacity configuration of the super capacitor energy storage device for the oil rig energy recovery microgrid system. Regarding the optimal configuration of microgrid energy storage capacity, domestic experts have carried out a lot of research on this, for example, Li Shengqing [4] et al. researched a method of optimal configuration of photovoltaic storage microgrid capacity based on the improved ant colony dynamic planning algorithm, and verified the practicability and superiority of this algorithm by

simulating and analysing the actual data of a district in Haining; Yuan Haozhe [5] et al. combined with the structure and photovoltaic characteristics of rural microgrid, to determine the charging and discharging characteristics of energy storage. characteristics, determine the charging and discharging strategies of energy storage, and comprehensively consider the load, tariff, and environmental benefits, and establish the optimal storage capacity allocation model based on the improved genetic algorithm with the goal of maximising the utilisation rate of photovoltaic and economic optimisation; Yuan Haishan ([6]) et al. constructed an optimisation model of the storage capacity containing the optimal economy for the scenario of wind-scenic coupled hydrogen microgrids, and used the storage regulation to achieve the energy balance, and improve the operational reliability; Chen Huaixin ([5]) et al. reliability; Chen Huaixin [7] et al. used genetic algorithm to optimize the control parameters and capacity configuration of the energy storage device to achieve the maximum economic efficiency of the supercapacitor energy storage device in the power supply system of the urban rail transit; Zhou Chengwei [8] et al. used the grey wolf algorithm to optimize the capacity configuration of the energy storage of the microgrid system based on the characteristics of the wind-scenic power generation and the energy storage microgrid, which makes the whole system's economy, energy utilisation rate is improved and the revenue from power sales is increased.

To address the rationality of the capacity configuration of the supercapacitor energy storage device of the oil rig energy recovery microgrid system, this paper formulates the charging and discharging strategy of the energy storage system based on the study of the structure of the oil rig microgrid system, and takes into account a variety of economic factors such as the cost of energy storage cost, pollutant emission reduction benefits, energy storage losses, etc., with the lowest total cost

of the energy storage system as the optimisation objective, and comprehensively researches the optimal configuration of energy storage capacity for the energy storage system of the oil rig microgrid, and uses a genetic algorithm for model optimisation. The optimal allocation of energy storage capacity is studied, and the model is optimised using genetic algorithm.

2. Structure and Modelling of Microgrid System for Ultra-deep Well Oil Drilling Rigs

2.1. Microgrid system structure for ultra-deep well oil rigs

Figure 1 shows the schematic structure of the energy recovery microgrid system of the ultra-deep well oil drilling rig, in which the diesel generator set serves as the power source, continuously injecting electrical energy into the public AC bus of the microgrid to ensure the stable operation and power balance of the whole microgrid system. During the lifting phase of the drill column, the winch motor is in electric

state, turning the input electric energy into mechanical energy to lift the drill column. And when the drill column or casing lowering operation is executed, the lowering speed is adjusted through the motor control strategy. At this time, the actual rotational speed of the motor is greater than the synchronous speed, resulting in an inverse relationship between the direction of the electromagnetic torque and the direction of the rotational speed, prompting the motor to enter the power generation state. In this power generation mode, the power generated by the motor is directly fed back to the DC bus [9]. A supercapacitor is installed on the DC bus to recover and store this power. When lifting the drilling tools, the supercapacitor storage device discharges the DC bus to replenish the power, and when lowering the drilling tools, the supercapacitor storage device is recharged, and a braking resistor is connected in parallel to the DC bus, so that the braking resistor will consume this part of the energy when the returned power exceeds the rated capacity of the energy storage device. This can effectively curb the phenomenon of excessive rise in DC bus voltage, and thus ensure that the drilling winch inverter can maintain its stable operation without being affected by abnormal voltage fluctuations.

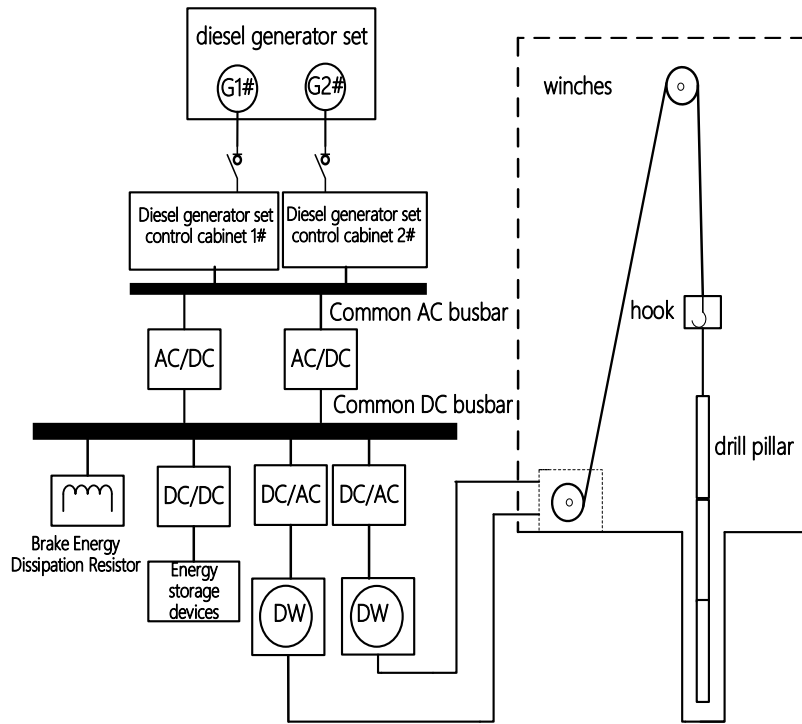

Figure 1. Schematic structure of energy recovery microgrid system for ultra-deep well oil rigs

2.2. Operational strategy

The control logic of the supercapacitor energy storage system is shown in Fig. 4, where the charging process and the discharging process are controlled separately. The logic judgement is based on the magnitude of the voltage parameter to determine whether the supercapacitor is charged or discharged. When the DC bus voltage V_{dc} is greater than the upper limit of the set reference value and the supercapacitor storage capacity, i.e., SOC, is less than the maximum capacity of the set reference, the transmission signal passes through the

logic regulation link to judge it as a charging mode, and then the supercapacitor is charged; when the V_{dc} is less than the lower limit of the set reference value and the SOC is greater than the minimum capacity of the set reference is satisfied, the transmission signal passes through the logic control link to judge it to be the discharging state, then the supercapacitor is discharged. In addition, in order to avoid the DC bus voltage is too high, and when the supercapacitor is fully charged, the braking energy-consuming resistor will intervene to ensure that the DC bus voltage is stable.

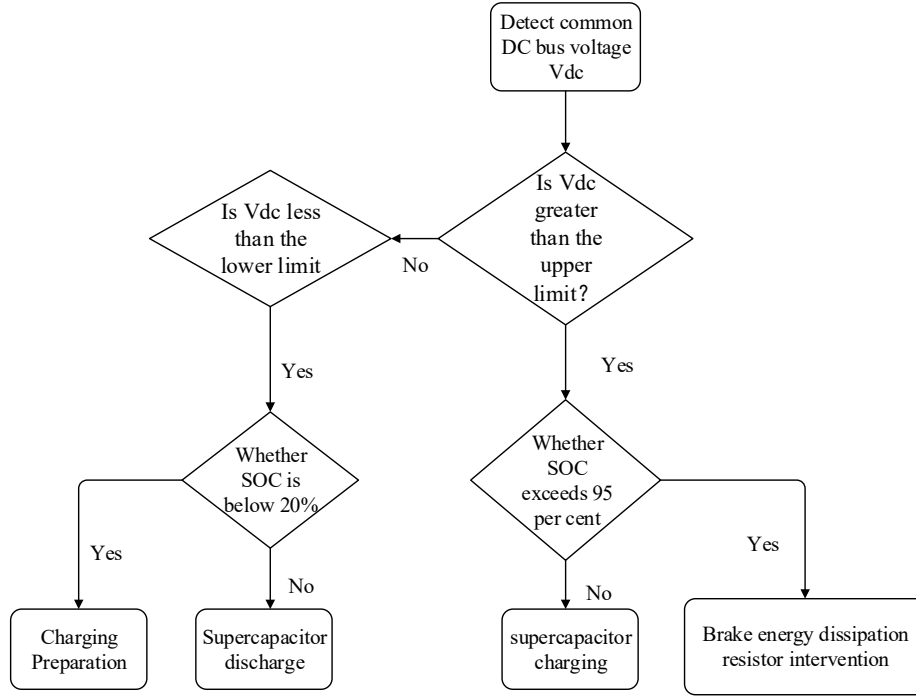

Figure 2. Control logic diagram of supercapacitor energy storage system

2.3. Calculation of recoverable energy for ultra-deep well oil rigs

Drilling rig winch in the process of lifting and lowering the drill, there are often four processes: lifting the drill column, lowering the empty hook, lowering the drill column, and lifting the empty hook. The kinetic and potential energies of the four phases will be analysed, and the energy consumed by the lifting of the drill column and empty hook and the energy recoverable by the lowering of the drill column and the empty hook will be calculated. The simplified force of the rig operation process system is shown in Fig. 2, the drilling column is mainly subjected to the tension of the wire rope, the gravity of the drilling column itself, Q is the average weight of the drilling column per metre in the air, M is the mass of the drilling column, h is the height of the drilling column, H is the depth of the well, k_1 is the static load modification coefficient for lifting up the drilling column, and k_2 is the static load modification coefficient for lowering down the drilling column.

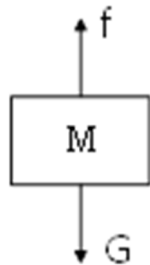

Figure 3. Simplified force diagram of the system

The weight of the weight drilling column during lifting and lowering operations:

$$M = Qhk \quad (1)$$

where k is a correction factor, k_1 when in lifting operation and k_2 when in lowering operation.

In lifting and lowering the drilling column, the energy is analysed into potential energy E_p and kinetic energy E_k , and the calculation of kinetic energy is divided into acceleration and deceleration parts for calculation.

(1) Kinetic energy

During the acceleration phase, the gravity is greater than the resistance, and the drilling column (casing) starts to accelerate. The acceleration is solved by the force at each stage, and then the height of the drilling column falling is derived from the initial and final velocities, and then the kinetic energy at each stage is calculated and summed to derive the total kinetic energy of the acceleration phase.

$$G - f = Ma \quad (2)$$

$$h_n = \frac{v_t^2 - v_{t-1}^2}{2a} \quad (3)$$

$$\Delta E_{1kn} = Gh_n - fh_n \quad (4)$$

During the deceleration phase, the drag force is greater than the gravity force, the drill column (casing) starts to decelerate, the acceleration and the height of descent can be obtained in the same way, and finally the total kinetic energy in the deceleration phase is obtained.

$$f - G = Ma \quad (5)$$

$$h_n = \frac{v_t^2 - v_{t-1}^2}{2a} \quad (6)$$

$$\Delta E_{2kn} = fh_n - Gh_n \quad (7)$$

The kinetic energy during the lifting or lowering of the drill column can be summed up from the kinetic energy of the acceleration phase and the deceleration, and then the total kinetic energy during the lifting or lowering of the drill

column can be obtained through the efficiency conversion.

$$\Delta E_k = \sum_1^n (\Delta E_{1kn} + \Delta E_{2kn}) \times \sigma \quad (8)$$

For uplift operations $\sigma = \frac{1}{\sigma_1}$, for downlift operations $\sigma = \sigma_1$, σ_1 generally take 0.72 [10].

(2) Potential energy

The potential energy during the lifting or lowering of the drill column can be calculated based on the potential energy at each stage of lifting or lowering height, and then summed and converted to efficiency to obtain the total potential energy during the lifting or lowering of the drill column.

$$\Delta E_{pn} = Mgh_n \quad (9)$$

$$\Delta E_p = \sum_1^n \Delta E_{pn} \times \sigma \quad (10)$$

Select a multi-model drilling rig as an example, under different conditions of well depth, calculate the energy consumed by lifting up the drilling column and the empty hook and the energy recoverable by lowering down the drilling column and the empty hook, of which the well depth interval is 1000~12000m, and select nine kinds of well depth working conditions. The weight of 5.5-inch drill pipe is calculated, the height of drill pipe $h=27m$; the average weight of drill pipe in air per metre $Q=36kg/m$; the weight of empty hook is as follows: Table 1; the static load correction coefficients of drill pipe lifting and lowering are as shown in Table 2 [11], and the magnitude of the velocity of drill pipe is as shown in Table 3 when the pipe is accelerating and then moving at uniform speed during the lifting and lowering.

Table 1. Empty hook weight

Well depth km	1	2	3	4	5	7	9	12
Weight t	4	6	8	10	15	18	20	25

Table 2. Correction factors

Well depth km	1	2	3	4	5	7	9	12
k1	0.94	0.98	1.04	1.09	1.16	1.29	1.50	1.81
k2	0.75	0.73	0.69	0.67	0.65	0.61	0.59	0.57

Table 3. Drilling speed

Speed m/s Weight t	Lifting of drilling tools	Unhooking	lowering of drilling tools	take up with an empty hook
0-120	0.65	0.50	1.00	0.55
130-180	0.25	0.45	0.30	0.60
190-260	0.10	0.40	0.10	0.65

After calculation, the energy characteristics of the four processes of drill column uplift (A), empty hook downlift (B),

drill column downlift (C), and empty hook uplift (D) were obtained, Total energy recovered (E), as shown in Table 4.

Table 4. Operational process energy characteristics

Well depth km Code name MJ	1	2	3	4	5	7	9	12
A	240	992	2399	4442	7356	15956	30587	61476
B	29	86	174	290	542	910	1299	2162
C	100	383	852	1414	2137	3911	6231	10822
D	55	167	336	558	1046	1755	2505	4172
E	129	469	1026	1704	2679	4821	7530	12984

The total energy consumed by lifting up the drill column, the total energy recovered by lowering the empty hook, the total energy recovered by lowering the drill column and the total energy consumed by lifting up the empty hook in Table 4 are described in a more intuitive form by Figure 3. The total amount of energy recovered by adding the energy recovered from empty hook lowering and drill pipe lowering to the total amount of energy recovered from the rig operation is visually depicted in Figure 4 as follows.

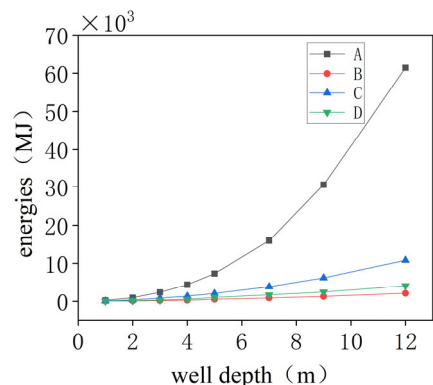

Figure 3. Energy consumption vs. recover

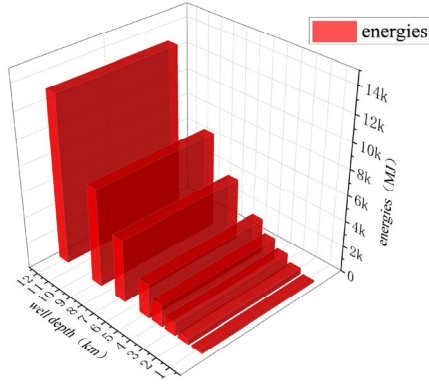

Figure 4. Total energy recovered graph

From Fig. 3, we can see that the energy characteristics of drilling column lifting or lowering and the energy characteristics of empty hook lifting or lowering both increase linearly with the increase of the well depth, in the well depth of 12,000m, the energy consumed by the drilling column lifting is 61,476MJ, and the recoverable energy of the drilling column lowering can reach 10,822MJ, which can be seen that the recoverable energy of the drilling column lowering is comparable to that consumed by the drilling column lifting, the total energy consumed by empty hook lifting is 4,172MJ, and the recoverable energy of empty hook lowering can reach 2,162MJ. The total energy consumed by lifting up the empty hook reaches 4172MJ, and the recoverable energy of lowering the empty hook reaches 2162MJ. The energy recovered by lowering the empty hook is comparable to the energy required by lifting up the empty hook, and if the energy recovered by the empty hook is utilised, the drilling cost can be effectively reduced.

2.4. Capacity Configuration of Supercapacitors

The safe and reliable operation of the oil rig winch supercapacitor energy storage system has a great relationship with the selection of suitable supercapacitors. Determining the specific parameters of the supercapacitor used in the energy storage system is the main research objective, and the energy generated during regenerative braking of the winch is recovered with high efficiency, so as to achieve the purpose of energy saving and emission reduction.

In the oil rig winch supercapacitor energy storage system, the number of supercapacitors is calculated according to the actual needs, and then the supercapacitor modules are formed according to the series-parallel connection to meet the voltage and current requirements of the energy storage system, and the total energy stored or released by the supercapacitor modules can be expressed as ([12]).

$$E = \frac{1}{2}C(V_{max}^2 - V_{min}^2) \quad (11)$$

Where C is the capacity of the supercapacitor in F; V_{max} and V_{min} are the maximum and minimum values of the supercapacitor terminal voltage in V, respectively.

In order to meet the requirements of practical applications, n supercapacitors of the same model are selected to be connected in series, and then connected in parallel to form m branches, forming an $n \times m$ supercapacitor module, whose

voltage relationship can be expressed as ([13]):

$$U = nU_m \quad (12)$$

The total capacity of the capacitor can be expressed as:

$$C = \frac{m}{n}C_m \quad (13)$$

Where U_m is the rated voltage of the capacitor unit; C_m is the capacity of the supercapacitor unit.

3. Super Capacitor Capacity Location Optimisation with Modelling

3.1. Objective function

In order to simultaneously consider the cost of energy storage, pollutant emission reduction benefits, energy storage losses and other economic factors, this paper proposes to establish the highest economic efficiency of supercapacitor energy storage system as the objective function of the optimisation of supercapacitor energy storage device capacity allocation scheme, defined as follows.

$$F = \max\left(\frac{P_{NOSC} - P_{SC}}{P_{NOSC}}\right) \quad (14)$$

Where P_{NOSC} is the cost of electricity required to operate the rig without supercapacitors and P_{SC} is the cost of electricity required to operate the rig with supercapacitors installed.

(1) Electricity costs for rig operations without supercapacitors.

$$P_{NOSC} = (A + B + C + D) * \eta * p \quad (15)$$

Where A, B, C, D are the energy characteristics of the four processes of drilling column lifting, empty hook lowering, drilling column lowering and empty hook lifting respectively, η is the energy conversion efficiency, and p is the electricity price.

(2) Electricity required for drilling rig operations when supercapacitors are installed

$$P_{SC} = (A - B - C + D) * \eta * p + C_i \quad (16)$$

Where C_i is the purchase cost of installing supercapacitors, mainly the purchase cost of supercapacitors, energy conversion devices, and auxiliary equipment, which can be expressed as follows.

$$C_i = C_{sc} + C_{PC} + C_{aid} \quad (17)$$

Where the first part C_{sc} is the purchase cost of the supercapacitor can be expressed as:

$$C_{sc} = (C_p P_{sc} + C_e E_{sc})R \quad (18)$$

Where: C_p and C_e are the cost per unit power and cost per unit capacity; P_{sc} and E_{sc} are the rated power and capacity, respectively, where $E_{sc} = P_{sc}T$, T is the discharge time; R is the equivalent annuity parameter of the system can

be expressed as ([14]) :

$$R = \frac{r(1+r)^n}{(1+r)^n - 1} \quad (19)$$

Where: r is the interest rate; n is the ultra-deep well winch supercapacitor energy storage microgrid operation cycle, generally n takes 30.

The second part C_{PC} can be expressed as

$$C_{PC} = C_z E_T \varphi \quad (20)$$

Where: E_T is the total energy recovered by the supercapacitor energy storage microgrid system of ultra-deep well winch, C_z is the unit power price of the energy conversion device, and φ is the conversion efficiency, which is usually 0.92.

The third part C_{aid} can be expressed as:

$$C_{aid} = \lambda_{aid} E_{sc} \quad (21)$$

Where: λ_{aid} is the price coefficient per unit capacity of auxiliary equipment.

3.2. Constraints

(1) Supercapacitor charge (SOC) constraints

In order to maximise the utilisation of the supercapacitor capacity, prolong the service life of the supercapacitor and prevent damage to the supercapacitor from over saturation, an upper and lower limit should be set for the residual capacity of the supercapacitor, which is expressed as.

$$SOC_{min} \leq SOC(t) \leq SOC_{max} \quad (22)$$

Where: SOC_{min} and SOC_{max} are the lower and upper limits of the SOC of the energy storage battery, which take the values of 0.1 and 0.9, respectively.

(2) Supercapacitor charging and discharging power constraints

$$\begin{cases} P_{cha_min} \leq P_{cha}(t) \leq P_{cha_max} \\ P_{disc_min} \leq P_{disc}(t) \leq P_{disc_max} \end{cases} \quad (23)$$

Where: $P_{cha}(t)$, $P_{disc}(t)$ are the charging and discharging power of supercapacitor at time t ; P_{cha_min} , P_{cha_max} are the charging lower limit power and upper limit power; P_{disc_min} , P_{disc_max} are the discharging lower limit power and upper limit power.

(3) Supercapacitor power rating and capacity constraints

$$\begin{cases} P_r \leq P_{max} \\ E_r \leq E_{max} \end{cases} \quad (24)$$

Where: P_{max} is the maximum limit power of supercapacitor; E_{max} is the maximum limit capacity of supercapacitor.

4. Research on Optimising the Capacity Allocation of Supercapacitor Energy Storage Device Based on Genetic Algorithm

4.1. Genetic algorithm model solving process

In order to get the maximum economic benefit of the supercapacitor energy storage device, this paper into the genetic algorithm in order to simultaneously optimise the supercapacitor energy storage device specific capacity configuration scheme. Genetic Algorithm (GA) is an adaptive probabilistic theory built on the basis of natural evolution theory and genetics mechanism. Its main features are that it operates directly on structural objects without the qualification of derivation and continuity; it has intrinsic hidden parallelism and better global optimisation search capability; it adopts probabilistic optimisation search method, which can automatically obtain and guide the optimised search space and adaptively adjust the search direction without the need of deterministic rules [16,17].

The flow of the genetic algorithm is shown in Fig. 5, and the basic steps are as follows.

(1) N initial individuals were randomly generated to form the initial population;

(2) The value of the fitness function was calculated for each individual;

(3) Based on the value of the fitness function, selection, crossover, and mutation are used to generate a new generation of populations;

(4) Judge whether the population meets the stopping condition, if not, return to step (2), if so, execute the next step;

(5) The optimal individual from the contemporary population is selected as the optimal solution to the optimisation problem.

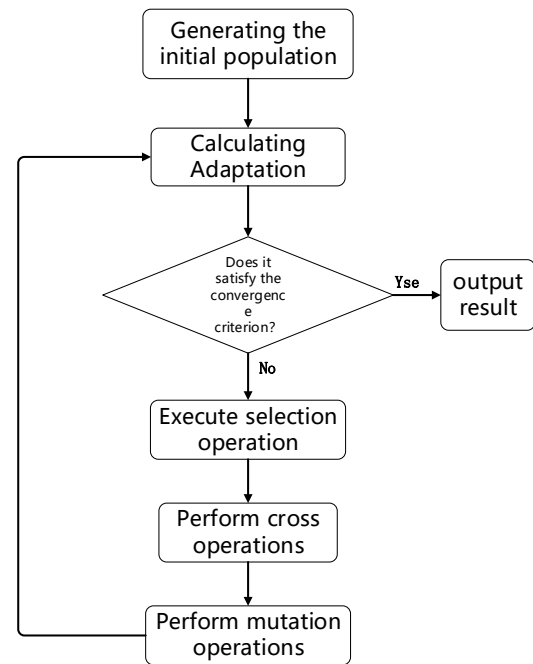

Figure 5. Flowchart of basic genetic algorithm

4.2. Analysis of examples

This paper takes different deep well oil drilling winch energy recovery microgrid system as an example, and the energy obtained when the maximum weight is recovered during the following drilling is used as the basis for

calculating the effective energy storage of supercapacitor, with the voltage range of 600V-800V, and the capacitor of 125V and 63F of a certain company is selected, and the supercapacitor is connected with several modules in series and parallel in order to increase the terminal voltage and the total storage capacity. The maximum terminal voltage of the supercapacitor module is designed to be 800V, the number of series connection of supercapacitor module is selected to be 5, and the total capacity of supercapacitor is determined by

the number of parallel connection m . The maximum terminal voltage of supercapacitor module is designed to be 800V. With the help of Matlab software to optimise the capacity of supercapacitors installed in the energy recovery microgrid system of the ultra-deep well oil rig, with the economic efficiency of the installed supercapacitor storage system as the optimisation objective, using into the genetic algorithm to solve the problem, the specific parameters of the example are as follows:

Table 5. Basic Parameters of the Arithmetic Example

name (of a thing)	numerical value	name (of a thing)	numerical value
Price per unit of power for energy conversion devices C_z (\$/W)	10	Capacitor Unit Power Cost C_p (\$/W)	900
Auxiliary Equipment Unit Capacity Price Factor λ_{aid} (\$/F)	600	Capacitor Unit Capacity Cost C_e (\$/F)	50
System operation and maintenance factor μ_{osc}	0.73	Electricity price p (\$/W)	10
Capacitor operating cycle life t (years)	12	Interest rate r	5%

Table 6 Corresponding parameters of the genetic algorithm

parametric	population size	genetic algorithm algebra	crossover probability	probability of mutation
numerical value	100	200	0.7	0.015

In MATLAB platform, through genetic algorithm, the result of solving 12000 metres well depth is shown in Fig. 6, and the result of 9000 metres well depth is shown in Fig. 7.

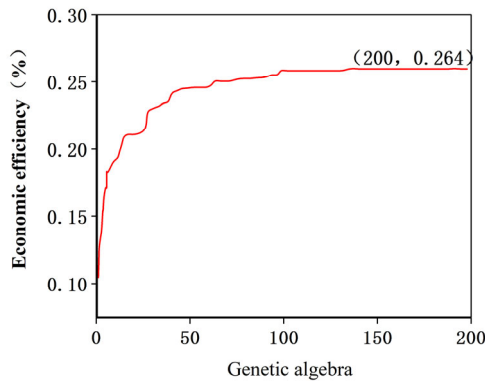

Figure 6. 9000 m well depth model solution results

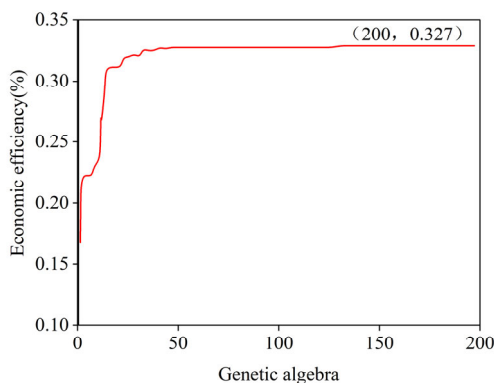

Figure 7. 12000 m well depth model solution results

As can be seen from Fig. 6 and Fig. 7, the objective function value (economic efficiency) gradually increases and tends to be stable as the number of genetic generations

increases, and the objective function (economic efficiency) is stable at about 26.4% when the depth of the well is 9,000 metres; and the objective function (economic efficiency) is stable at about 32.7% when the depth of the well is 12,000 metres. It can be seen that as the depth of the well becomes larger, the higher the economic efficiency of the oil drilling winch microgrid system recovery.

The capacity configuration with the highest economic efficiency for establishing an ultra-deep well oil drilling winch energy recovery microgrid system is obtained by genetic algorithm solution as shown in Table 7.

Table 7. Capacity Configuration Table

Well depth (m)	Capacitor combinations (n x m)	efficiency
9000	5 x 377	26.4 per cent
12000	5 x 650	32.7 per cent

5. Conclusion

In this paper, firstly, the super capacitor energy recovery microgrid system for ultra-deep well oil drilling rigs is modelled, and the system operation strategy is designed, and then the recoverable energy of the microgrid system is mathematically modelled and calculated, and the economic efficiency of the system's energy recovery is taken as the optimization goal, and the genetic algorithm is used to optimize the capacity allocation of the super capacitor. The following conclusions can be obtained:

(1) When the drilling rig operates, the recoverable energy is large. The energy characteristics of drill column uplift or downlift and the energy characteristics of empty hook uplift or downlift both show a linear growth relationship with the increase of well depth, and in the well depth of 12,000m, the energy consumed by the drill column uplift is 61,476MJ, and the recoverable energy of the drill column downlift can reach 10,822MJ.

(2) Through the genetic algorithm, when the well depth is

12,000m, the economic efficiency of energy recovery can reach 26.4%; when the well depth is 9,000m, the economic efficiency of energy recovery can reach 32.7%; with the increase of the well depth, although the economic efficiency of energy recovery decreases, it is more than 25%, which is more considerable.

(3) The optimised supercapacitor energy storage capacity configuration scheme and the achieved economic efficiency of energy recovery in this paper can provide corresponding reference help for the establishment of energy recovery microgrid system for oil drilling winch in super-lift wells.

References

- [1] LIU Peng, DING Bin, LI Lei, et al. Research on energy storage technology of oil rig winch[J]. *Modern Manufacturing Technology and Equipment*, 2021, 57(4): 38-39, 44.
- [2] LI Jianwen, LI Yunfeng, LU Tao, et al. Simulation study of super capacitor energy storage system for drilling winch[J]. *Petroleum Machinery*, 2022, 50(2): 39-45.
- [3] Liu Yibing. Design and analysis of super capacitor energy storage system for drilling rig winch [D/OL]. Xi'an Petroleum University, 2019[2024-11-19].
- [4] Optimal Capacity Allocation of Optical Storage Microgrids Based on Improved Ant Colony Dynamic Planning_Shengqing Li [M].
- [5] Research on Optimal Allocation of Optical Storage Capacity for Rural Microgrid_Yuan Haozhe [M].
- [6] Research on the optimal allocation method of microgrid energy storage capacity for wind-solar coupled hydrogen production_Yuan Haisan [M].
- [7] CHEN Huaixin, YANG Zhongping, LIN Fei, et al. Optimisation of energy management and capacity allocation of supercapacitor energy storage device for urban rail transportation based on genetic algorithm[J]. *Journal of Railway*, 2019, 41(9): 59-66.
- [8] ZHOU Chengwei, LI Peng, YU Bin, et al. Optimal allocation of energy storage system capacity for wind-solar-storage microgrid[J]. *Integrated Intelligent Energy*, 2022, 44(12): 56-61.
- [9] Zhenzhong Zhang, Pengxiao Wang, Xinhua Yang. Coordinated control strategy of hybrid energy storage system for oil rig microgrid[J]. *Electrical Drives*, 2020, 50(2): 82-87.
- [10] TAI Mingshi, LIU Jiarong, WANG Yuchao. Application and analysis of permanent magnet synchronous motor in winch hoisting system of deep well drilling rig[J]. *Drilling Engineering*, 2023, 50(S1): 465-470.
- [11] CUI Xuezheng, GUAN Zhichuan, HAN Zhiyong, CHEN Yibao, SUN Chengtang. Mechanical structure design and manufacture of drilling column measuring joint[J]. *Mechanical design*, 2002(3): 30-32.
- [12] WU Jing, ZHANG Le. Capacity allocation and energy optimisation of energy storage systems in rail transportation[J]. *Energy Storage Science and Technology*, 2024, 13(11): 4053-4055.
- [13] SUN Yang, ZHAO Shiyu, ZHANG Xiaomei, et al. Progress of electrode materials for biochar-based supercapacitors[J]. *Renewable Energy*, 2024, 42(11): 1440-1448.
- [14] Zhou Chengwei. Research on optimal allocation of energy storage capacity based on wind-solar storage microgrid [D/OL]. Nanjing University of Information Engineering, 2024[2024-10-12].
- [15] Guo Guizhi. Research on energy storage capacity allocation and cooperative optimal operation of community microgrid [D/OL]. Guangxi University, 2023 [2024-11-16].
- [16] Wang XD, Liu XM. Research on optimal capacity allocation of microgrid hybrid energy storage system based on genetic algorithm[C/OL]//Twelfth Shenyang Science Academic Annual Conference. Shenyang, Liaoning, China, 2015: 192-196 [2024-11-28].
- [17] YANG Guohua, ZHU Xiangfen, ZHOU Xin, et al. Optimal allocation of hybrid energy storage capacity for wind power based on genetic algorithm[J]. *Electrical Drives*, 2015, 45(2): 50-53.