

Influence of Different Supporting Structures on Supporting Deformation of Long and Deep Foundation Pit of Railway

Boshuo Cao

College of Civil Engineering, Lanzhou Jiaotong University, Lanzhou 730070, China

Abstract: In this study, the influence of different pile diameters and supporting materials on deformation characteristics of long and deep foundation pit supporting structure of railway is systematically analyzed by finite element simulation method. The research results show that the lateral displacement of diaphragm wall exceeds the safety limit of 20mm due to the lack of cross-sectional stiffness of 800mm diameter protective piles, while the displacement control effects of 1000mm and 1200mm diameter protective piles are similar, but the latter has poor economic benefits. In the selection of supporting materials, the influence of concrete bracing or steel bracing on lateral displacement of protective piles is not significant, but steel bracing has more advantages in controlling vertical displacement of deep bracing. It is also found that the diagonal brace and corner reinforcement structure can effectively restrain the corner displacement of foundation pit, and increasing the pile diameter to 1000mm can significantly enhance the restraint of soil around the pile and improve the internal force distribution of the structure. Comprehensive technical and economic analysis shows that the composite supporting scheme with 1000mm diameter protective pile and steel support can not only meet the requirements of deformation control, but also have good engineering economy, which can be used as the optimal supporting scheme for similar long and deep foundation pit projects.

Keywords: Deep foundation pit; Supporting structure; Pile diameter effect; Finite element analysis; Deformation control.

1. Introduction

Deep foundation pit bracing as a deep foundation pit stress structure-researchers at home and abroad have carried out research on deep foundation pit bracing, for the deep foundation pit bracing structure of the mechanical properties of the exploration and optimization, there have been some theoretical analysis and experimental research results.

Scholars at home and abroad have studied earth pressure for more than 200 years. Early studies include Rankine W J[1]As an important achievement based on limit equilibrium theory, Rankine earth pressure theory is still widely used in engineering practice. Peck[2]By analyzing the measured data of axial force of sheet pile and occlusal pile, the distribution law of excavated pressure is deduced. Finn[3]The failure mechanism of Coulomb line is studied by limit analysis method. Nakai[4]Then the elastic-plastic connection element is used to analyze the earth pressure distribution of retaining wall under different displacement modes. Li Yongsheng[5]Based on the study of the retaining structure of Shanghai Museum, it is found that the static earth pressure acts on the retaining structure at the initial stage, and with the increase of excavation depth, the displacement gradually decreases and finally tends to the active earth pressure state. Lu Tinghao[6]Based on Coulomb's earth pressure theory, a formula for calculating active earth pressure of clayey soil is proposed, which considers the cohesive force of clayey soil and the cohesive force of soil to the back of wall. Li Feng[7]Based on the generalized Coulomb earth pressure theory, combined with analytical method, analytical method and numerical analysis method, the earth pressure calculation method of cohesive soil is derived and applied to practical engineering. Mana[8]The new fabricated steel slanting bracing structure is designed to systematically study the deformation characteristics of foundation pit support system

by finite element theory, which shows the advantages of low layout density, fast construction speed and strong deformation control ability. These research results jointly promote the development of deep foundation pit support theory and the optimization of engineering practice. 2. Establishment of finite element model

2. Model

2.1. Establishment of foundation pit model

In mesh generation, hybrid mesh generator is used to balance calculation accuracy and efficiency. The excavation area of the foundation pit adopts a grid of 2~3 meters, the surrounding soil is 3~4 meters, and the size of the far area is appropriately increased. A total of 209,749 units are generated in the final model, which not only ensures the calculation accuracy, but also reduces the calculation time. The grid division is shown.

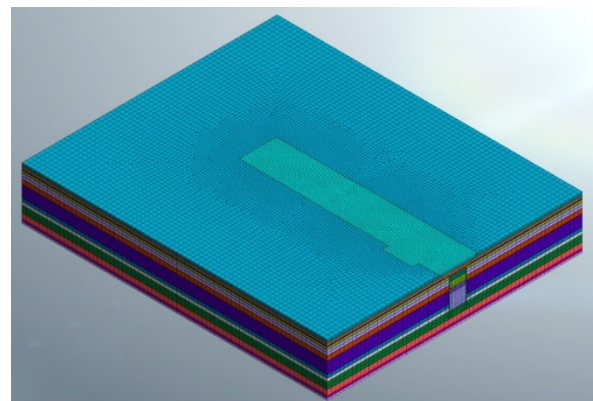

Figure 2.1. Three-dimensional model diagram of mesh division

The displacement nephogram of supporting structure under different excavation conditions is shown in the following figure:

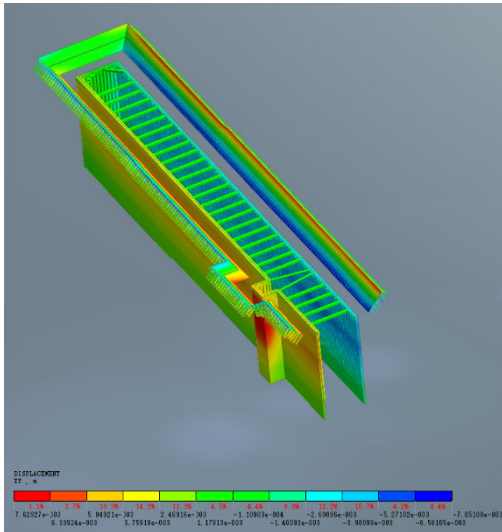

Figure 2.2. Longitudinal Displacement of Supporting Structure in the First Excavation

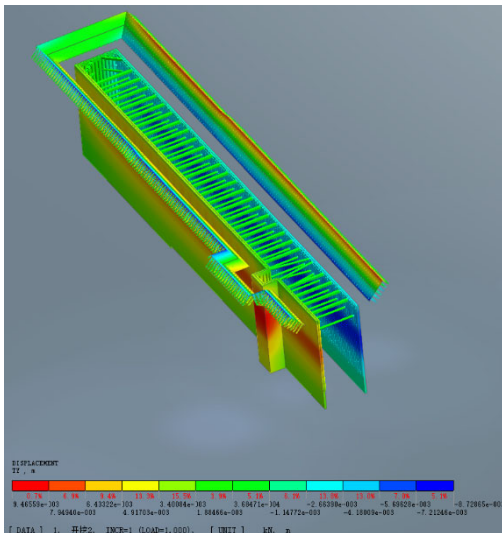

Figure 2.3 Longitudinal Displacement of Supporting Structure in the Second Excavation

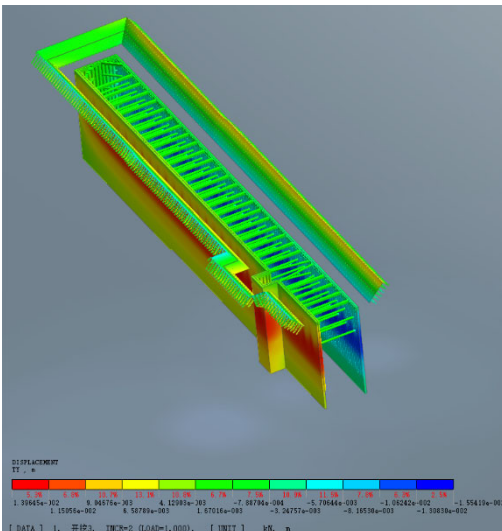

Figure 2.4 Longitudinal displacement diagram of supporting structure during the third excavation

With the increase of the depth of the foundation pit, the soil around the foundation pit gradually undergoes stress release, which leads to the gradual increase of its deformation, which will intensify the influence on the lateral pressure and vertical load of the supporting structure.

2.2. Selection of finite element support scheme

Different support schemes are shown in Table 1.

Table 2.1 Support Scheme

Support scheme	Support type
Option 1	Soil nailing + shotcrete + 1000mm retaining pile + crown beam + diaphragm wall + steel purlin + concrete support + \varnothing 800 steel support
Option 2	Soil nailing + shotcrete + 1000mm retaining pile + crown beam + diaphragm wall + steel purlin + three-story \varnothing 800 steel support
Option 3	Soil nailing + shotcrete + 800mm retaining pile + crown beam + diaphragm wall + steel purlin + concrete support + \varnothing 800 steel support
Option 4	Soil nailing + shotcrete + 1200mm retaining pile + crown beam + diaphragm wall + steel purlin + concrete support + \varnothing 800 steel support

According to the above schemes, the finite element simulation and comparison are carried out, and the supporting scheme suitable for long and deep foundation pit of railway is selected.

3. Finite Element Analysis of Long and Deep Foundation Pit

3.1. Influence of different pile diameters on peripheral settlement

Analysis of structural displacement at different pile diameters is shown in Figure 3.1 below

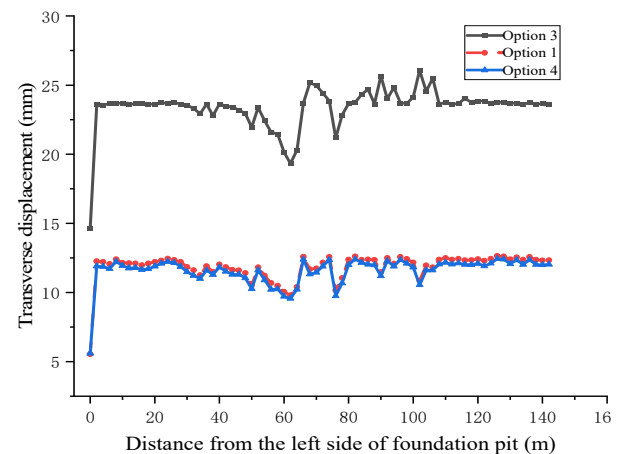

Figure 3.1. Transverse displacement of diaphragm wall with different pile diameters

The horizontal displacement of diaphragm wall is the smallest in the corner of foundation pit due to the restraint of diagonal brace, concrete corner brace and steel foot brace. Compared with different diameters of protective piles, the displacement of diaphragm wall with 800mm pile diameter

exceeds 20mm, which does not meet the safety standard; The displacement of 1000mm and 1200mm pile diameters is close, but the increase of pile diameter has limited effect on supporting effect. Comprehensive analysis of supporting deformation shows that 1000mm protective pile has better performance in displacement control and stability, which is an ideal choice for railway deep foundation pit support and can effectively balance safety and economy.

3.2. Vertical displacement analysis of steel (concrete) bracing structure

(1) The influence of different materials on the vertical displacement of the support structure is shown in Figure 3.2 below:

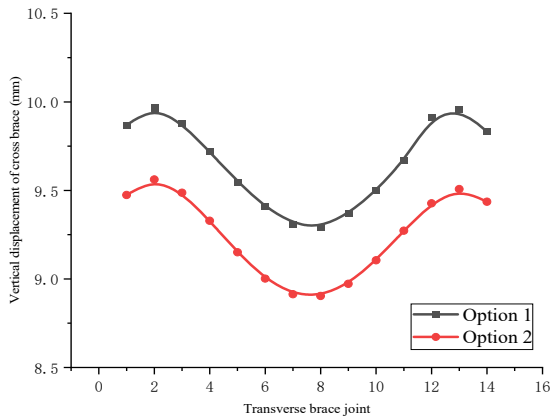

(a) Deformation of the first layer of cross brace

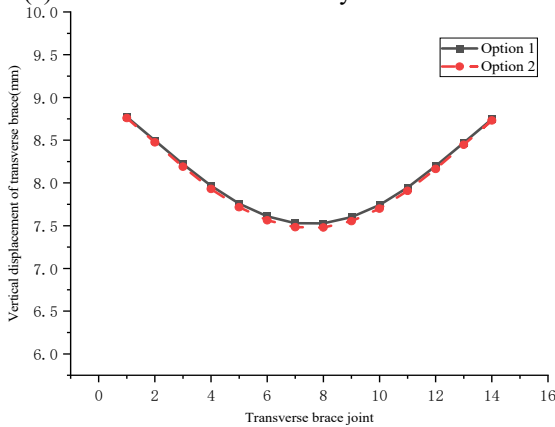

(b) Deformation of the second layer of cross brace

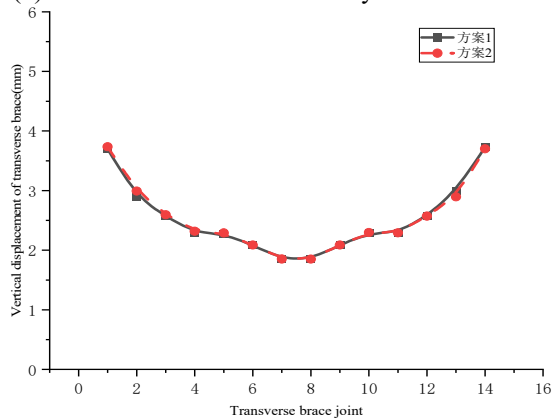

(c) Deformation of the third layer transverse brace

Figure 3.2. Transverse brace deformation diagram of different materials

increases from 9mm to 9.41 mm (+4.56%), the second bracing increases from 7.56 mm to 7.61 mm (+0.66%), and the third bracing increases from 2.28 mm to 2.29 mm (+0.43%). Compared with concrete bracing, steel bracing can restrain deformation more effectively by virtue of its higher rigidity, especially in the second and third floors, and has stronger overall displacement resistance.

(2) Influence of different pile diameters on vertical displacement of bracing structure

During construction, the transverse brace will be deformed due to earth pressure, and the deformed brace will affect the safety of subsequent construction. The deformation of the brace is shown in Figure 3.3 below

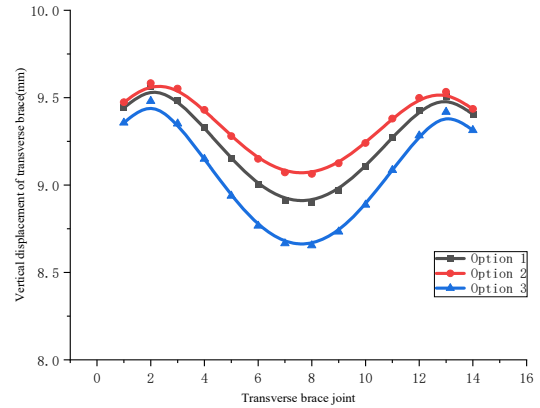

(a) Displacement diagram of the first floor supporting structure

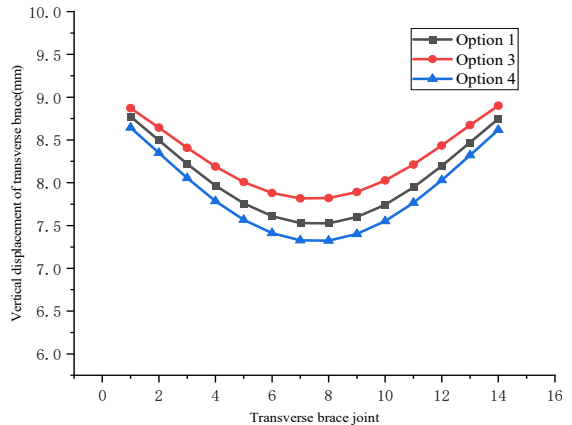

(b) Deformation diagram of the second floor supporting structure

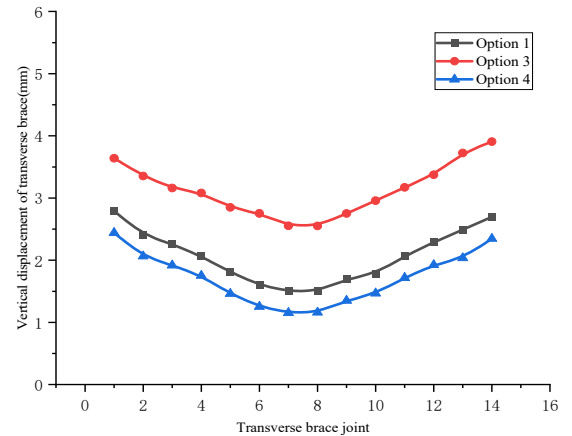

(c) Deformation diagram of the third layer of cross brace

After replacing the first concrete bracing with steel bracing, the vertical displacement increases slightly: the first bracing

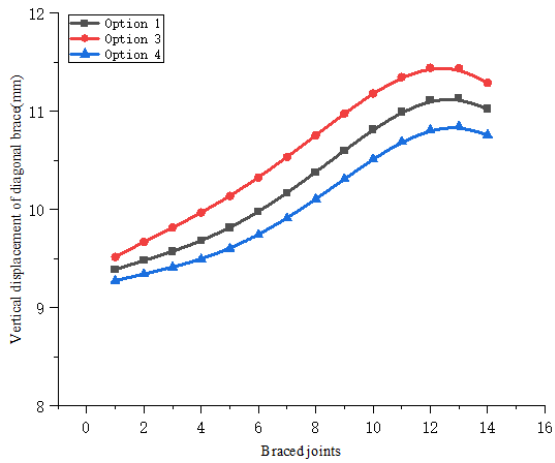

(e) Deformation diagram of the first layer of diagonal brace

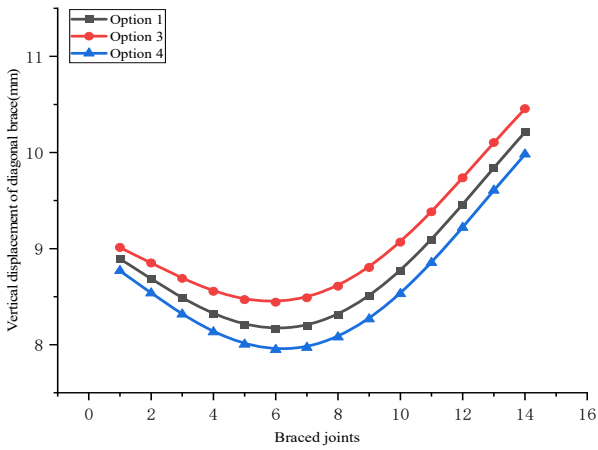

(f) Deformation diagram of the second layer of steel support

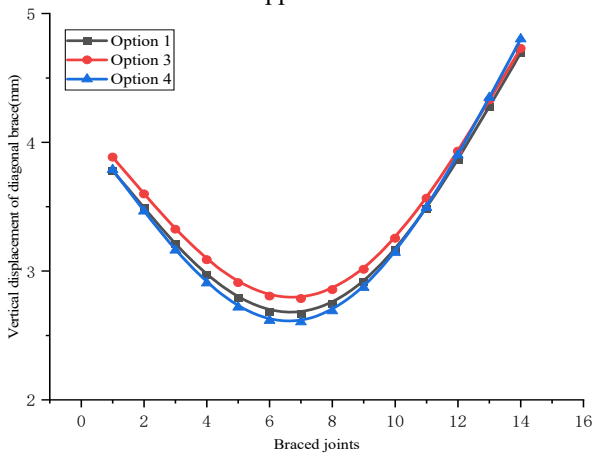

(g) Deformation diagram of the third layer of steel support
Figure 3.3. Deformation diagram of support structure with the same pile diameter

Comparing the data of support scheme, it can be seen that the displacement of transverse brace in scheme 3 (800mm pile diameter) is 9.07 mm (the first layer) and 7.82 mm (the second layer), and the displacement of diagonal brace is 10.76 mm and 8.61 mm, with the largest deformation; The displacement of scheme 1 (1000mm) and scheme 4 (1200mm) is similar (for example, the first layer of cross brace 8.91 mm > 8.67 mm). When the pile diameter increased to 1000mm, the displacement decreased significantly, but the improvement was limited when the pile diameter increased to 1200mm (the decrease was less than 3%). Comprehensive cost performance,

1000mm pile diameter is the best, which can not only control the displacement (meet the requirement of < 9mm), but also save the cost.

3.3. Lateral displacement analysis of protective pile

The influence of different bracing materials on the bending moment of bracing structure

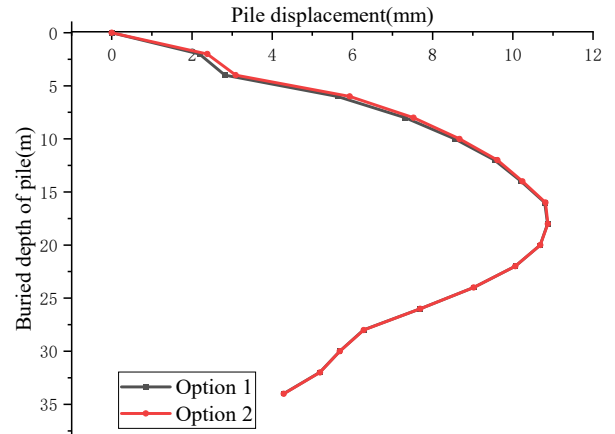

(a) Displacement diagram of protective pile at corner of foundation pit

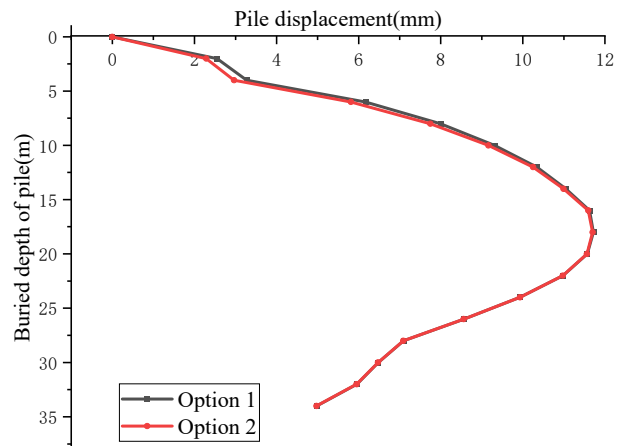

(b) Displacement diagram of protective pile at middle of foundation pit

Figure 3.4. Displacement diagram of protective piles with different pile diameters

When concrete bracing and steel bracing are used as the first layer bracing, the influence on the displacement of protective pile is similar. Concrete braces provide stiffness with large cross-section, while steel braces rely on high elastic modulus, and their overall stiffness is equivalent. Under the same load distribution and boundary conditions, because the force is uniformly transferred to the protective pile through the purlin, the pile reaction force and lateral displacement produced by the two kinds of braces have little difference. Simple replacement of supporting materials can not significantly change the displacement of pile.

Influence of different pile diameters on axial force of bracing.

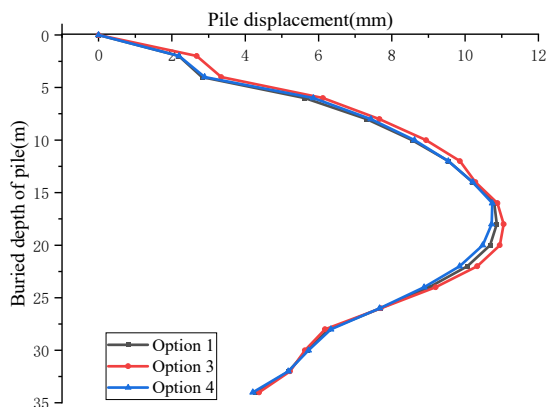

(a) Displacement diagram of protective pile at corner of foundation pit

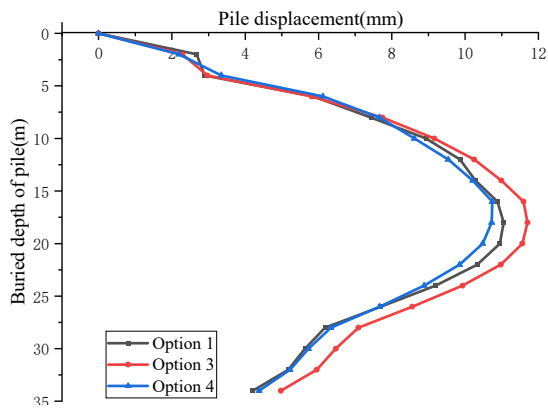

(b) Displacement diagram of protective pile at middle of foundation pit

Figure 3.5. Displacement diagram of protective piles with different pile diameters

Under the same load, the lateral displacement of 800mm piles is obviously larger than that of 1000mm and 1200mm piles because of the small moment of inertia. Larger pile diameter (1000/1200 mm) can drive more soil around the pile, enhance the constraint of soil, and increase the modulus of flexural section significantly reduces the stress level, so the displacement difference between them is small. However, 800mm pile has poor displacement control ability due to

insufficient stiffness and weak soil constraint.

4. Conclusion

Through finite element simulation, the supporting system of long and deep foundation pit of railway is systematically analyzed, and the results show that the combination scheme of 1000mm diameter protective pile and steel support is the best in terms of technical and economic performance. This scheme can not only effectively control the horizontal displacement of diaphragm wall within the safety limit of 20mm, but also significantly reduce the project cost compared with the scheme of 1200mm pile diameter. It is found that when the pile diameter increases to 1000mm, the soil restraint effect around the pile is obviously enhanced, but the improvement effect of displacement control by continuing to increase the pile diameter is limited. In the aspect of support system, steel bracing shows better displacement control ability than concrete bracing in deep bracing, but there is little difference between them in the effect of first-floor bracing.

References

- [1] Rankine W J M. On the stability of loose earth[J]. Philosophical transactions of the Royal Society of London, 1857 (147):9-27.
- [2] Peck B B. Deep excavation and tunnelling in soft ground, State of the art volume[C].7th ICSMFE.1969, 4:225-290.
- [3] Finn W D L. Creep and creep rupture of undisturbed sensitive clay [C]. Proceedings of the 8th ICSMFE. 1973, 1:135-142.
- [4] Nakai T. Analysis of earth pressure problems considering the influence of wall friction and wall deflection[C].International conference on numerical methods in geomechanics. 1985:765-772.
- [5] Li Yongsheng. Stress and deformation of retaining structure of foundation pit of Shanghai Museum [J]. Journal of Geotechnical Engineering, 1996 (03): 55-61.
- [6] Lu Tinghao. Active earth pressure formula considering cohesion and wall back adhesion [J]. Rock and Soil Mechanics, 2002 (04): 470-473.
- [7] Li Feng, Guo Yuancheng. Calculation and analysis of active earth pressure of finite soil in foundation pit engineering [J]. Building Science, 2008 (01): 15-18.