

# Structural Finite Element Analysis of A Novel Lifting Formwork for Thin-walled High Piers with Variable Cross-section

Weidong Zhao<sup>1, a, \*</sup>, Changqiong Yang<sup>1, b, \*</sup>, Yongxing Wang<sup>1, c, \*</sup>, Feiyue Li<sup>1, d, \*</sup>

<sup>1</sup>Yunling construction Co, ltd of YCIC group, Kunming, Yunnan Province 6500041, PR China

<sup>a</sup>562598783@qq.com, <sup>b</sup>664147995@qq.com, <sup>c</sup>83158301@qq.com, <sup>d</sup>438093812@qq.com

\* Corresponding Author Email

**Abstract.** According to the background of the construction project, a new type of formwork structure for thin-walled high piers with variable cross-section is proposed, which realizes safe and efficient reversal of the formwork by lifting the outer frame as a whole and introduces the construction technology of the formwork structure system. Through the finite element software modeling of the overturning structure, the corresponding load conditions are established according to the actual working conditions of the project, and the force and deformation of the overturning structure are thus calculated, which ensures the quality of the project very well.

**Keywords:** Variable section structures, high bridge pier, formwork construction, mechanical analysis.

## 1. Introduction

In order to meet the urgent development of ground transportation in mountainous areas and other complex landscapes, high-level highway construction will appear high-altitude large-scale pier structure, often higher than 50 meters, which brings certain difficulties to the main structure construction safety, structural construction technology programs need to meet the requirements of safety, economy, practicality and so on [1-4]. The key to the construction of the template system innovation and technology iteration, combined with the characteristics of the project, the use of a new type of thin-walled high piers for variable cross-section of the new template structure, the template system through the overall lifting of the outer frame to achieve the template of the safety and efficiency of the inversion, compared to other technical solutions [5-8], has a very high safety and breakthrough construction efficiency, to ensure that the construction of high and large-scale piers structure is completed successfully.

## 2. Project Overview and Formwork Solution Selection

Located in Huize County, Yunnan Province, China, this project is a key construction node and a major difficult construction task for the highest grade highway. This project in order to ensure safety, improve quality, quality assurance in the construction of high piers, so the project department to carry out technical attacks put forward high piers as a whole to enhance the outer frame to realize the safety of the template and efficient inversion of the construction process. In the construction formwork solution selection, the program should meet the following requirements: (1) to ensure construction safety; (2) to solve the problem of variable slope, variable diameter, variable cross-section construction; (3) a better solution to the problem of vertical transportation; (4) to solve the problem of multi-point control and communication of electrical equipment; (5) affordable.

On the basis of traditional climbing mold, we have developed the overall frame lifting and in the gap between the frame and the outer wall of the pier to carry out efficient and safe formwork inversion system, the formwork to increase the horizontal long openings and articulated rods to achieve the high piers of the variable slope, the requirements of the variable cross-section. The fixed angle steel ring is changed to adjustable truss ring to meet the requirements of different curvatures of the tower body, and avoid the use of through the hall tensile screw, significantly improve the quality of the outer surface of the pier construction and aesthetics, and improve the durability of high piers in mountainous areas in complex climatic conditions.

### 3. Principles of Formwork Construction

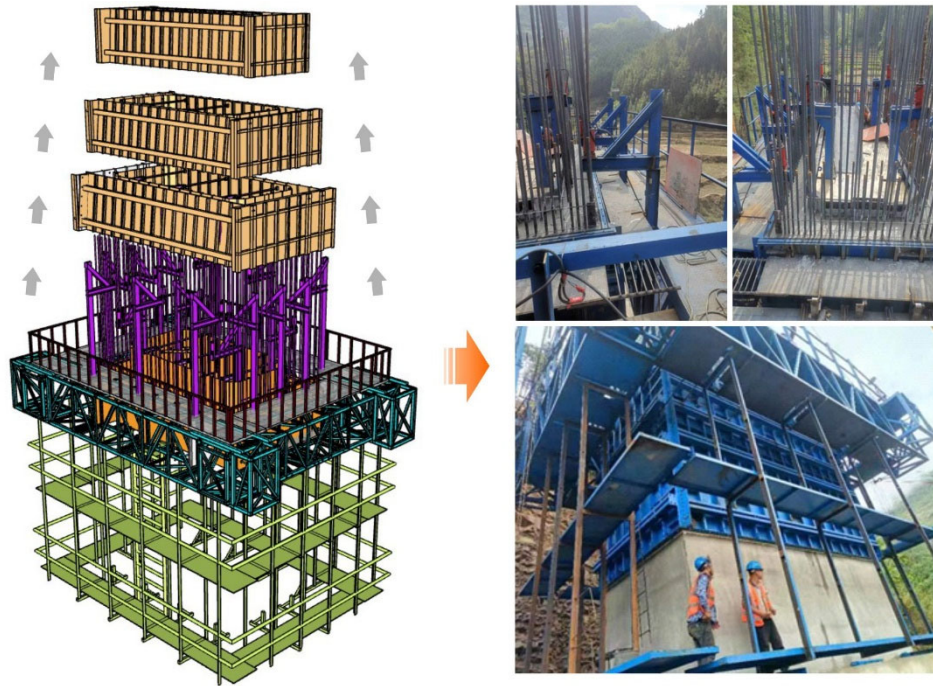

**Figure 1.** Variable-section thin-walled pier lifting form inverted molding system elevation and site construction drawings

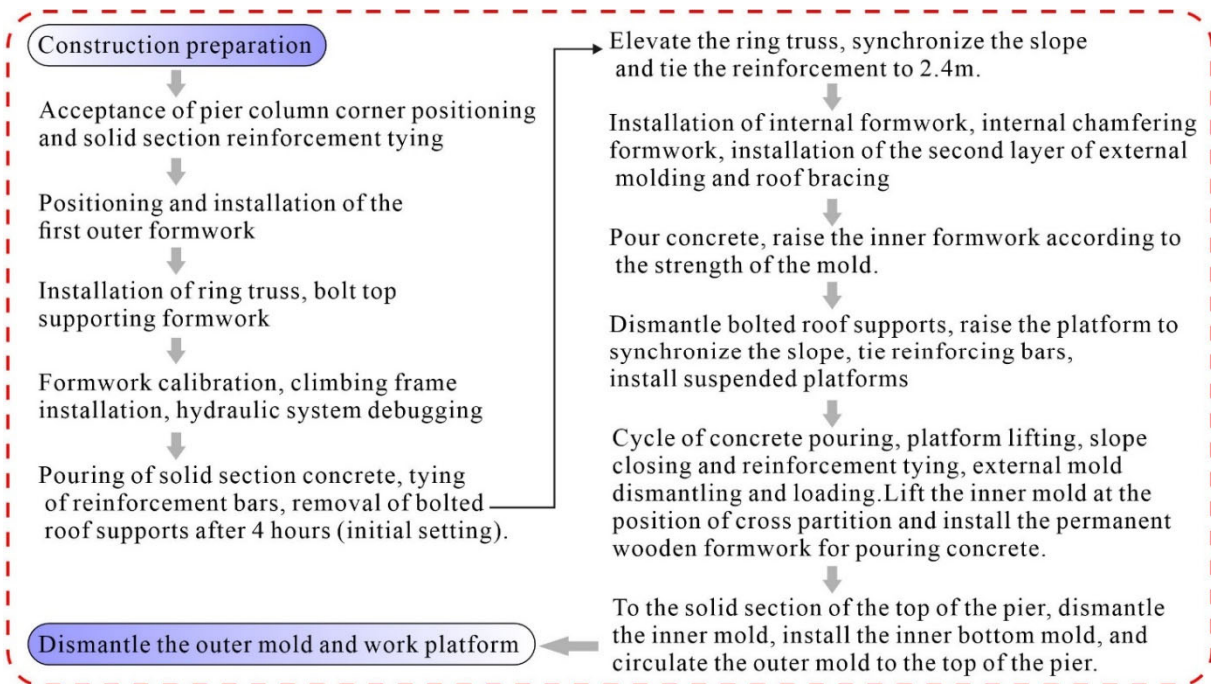

**Figure 2.** Variable cross-section thin-walled pier lifting frame inverted mode double-layer formwork construction flowchart

Variable cross-section thin-walled pier lifting frame inverted mold technology for Yunnan Jiaotou Group Yunling Construction Co., Ltd. science and technology research and development project (YLJS-KF-2024-01) of the patented template technology. The outer frame of the stress system is mainly composed of crawler frame fixed 10T wedge jack and supported on 6 48\*3.5 steel pipe crawler bars. The constant load of truss, climbing frame, suspension platform and hydraulic equipment is 14.5

tons. Variable load is calculated according to the area all uniform load is not allowed to exceed 4 tons. Constant load of 5 tons for internal mold and its support as well as hydraulic equipment, etc. Variable load is allowed not to exceed 3 tons, as showing in Fig 1.

The construction process is divided from the pier column part mainly has the pier bottom solid section construction, standard thin wall section construction, cross partition construction and pier top solid section construction, the corresponding template system is completed in the pier bottom section of the first layer of template installation, circle truss installation, the second template installation, operation platform installation, internal mold installation, the pier top is gradually complete the removal of the internal mold, the demolition of the two layers of templates, the removal of the circle trusses and platforms, the flowchart is shown in Fig. 2. After pouring the bearing platform, the outer edge line of the pier column should be measured and placed, and the first layer of outer formwork can be assembled after the reinforcement is finished, because the technology has canceled the tie bar, the formwork can't withstand the lateral pressure of the concrete pouring, and it is necessary to install the ring truss to support the formwork laterally. The main point of this stage is that temporary support (steel bench) is needed under the hoop truss to support the hoop truss, the installation position of the formwork should be accurate and accurate, and it is necessary to ensure that the formwork is installed vertically by using a wire hammer, and the bolt top support is fixed firmly. Crawling pole, wedge jack, lifting frame can be poured concrete after installation and debugging. The slope between the templates through the small-surface template “clamped” large-surface template way to close the break, which in the large-surface template end of the flange and oblong holes, the corresponding small-surface template plane perpendicular to the large-surface template and open the spacing of 120-140mm bolt holes through the high-strength bolts and the large-surface bolted to the oblong holes. The first cycle of the external formwork, i.e. the cumulative lifting of the operating platform to a height of 4.8m and the completion of the remaining reinforcement binding of the second mold, meanwhile, the installation of the internal formwork system and debugging of the hydraulic system for slope closing and lifting of the internal mold.

#### 4. Model Analytics

In this case, variable cross-section thin-walled hollow pier lifting frame inverted mold is divided into outer truss and outer double-layer template, as well as the inner mold and the corresponding slope adjustment cylinder hydraulic system, template system main parameters are as follows.

**Table 1.** Main structural parameters of the formwork system

Structures	Material/Specifications	Amount	Note
1 Long side trusses	Q235, H-W-D m: 11*1.16*1.7	2	Chord L100*10, web L63*5
2 Short side trusses	Q235, H-W-D m: 7.6*1.16*1.45	2	Chord L100*10, web L63*5
3 Exterior Climbing Frame	Q235, 4.8m/3.72m	4/2	18a# double channel welded with inverted triangle diagonal bracing, rigidity control
4 Internal Mold Crawler	Q235, 3m	4	18a# Channel Welded 10mm Steel Plate with Triangle Tie Rods
5 Outer Form / Adjustment Form	Q235, THK 5mm	4	10# channel steel reinforcement plate spacing 0.4m, peripheral L100*10 angle steel flange. 14 tons.
6 Internal Form	Q235, THK 5mm		80# channel steel reinforcement plate spacing 0.35-0.37m, peripheral L80*8 angle steel flange, 4 tons
7 Operating platforms	2.5mm patterned steel plate		Load shall not be greater than 3KN/m <sup>2</sup>
8 Suspension platforms	2.5mm patterned steel plate		Load shall not be greater than 2KN/m <sup>2</sup>

According to the “safety technical specification for formwork of building construction” (JGJ162-2008), when internal vibrator is used, the standard value of lateral pressure of the newly poured concrete acting on the formwork can be calculated according to the following formula, and take the lesser of these values:

$$F=0.22\gamma_{ct}\beta_1\beta_2V^{1/2}$$

$$F=\gamma_cH$$

Concrete lateral pressure calculations:

$$F=0.22\gamma_{ct}\beta_1\beta_2V^{1/2}=0.22\times 25\times 200/35\times 1.2\times 1.15\times 2^{1/2}=61.34\text{KN/m}^2$$

$$F=\gamma_cH=25\times 2.4=60\text{KN/m}^2$$

Take the smaller value between the two, so the standard value of lateral pressure of freshly poured concrete on the formwork  $F = 60\text{KN/m}^2$ . The standard value of the load generated when dumping concrete is  $2\text{kN/m}^2$  for vertical face formwork.

According to “building construction template safety technical specification” (JGJ162-2008) and stent load effect combination of the standard value of the load combination:

Strength checking:  $F_{\text{max}}=1.2\times F+1.4\times Q_{3k}=1.2\times 60+1.4\times 2=74.8\text{kN/m}^2$

Stiffness checking:  $F_{\text{max}}=F=60\text{kN/m}^2$ .

Hollow thin-walled pier formwork panel adopts 5mm thick steel plate, after the panel set [10 channel steel, channel steel maximum spacing of 1264mm. panel according to three equal span continuous beam calculation, calculation span diameter take 493mm, 1264mm, 493mm, take the width of the plate 1m. 5mm thick panel calculation parameter: unit weight  $19.65\text{KN/m}^3$ ,  $f = 215\text{MPa}$ ,  $f_v = 125\text{MPa}$ , modulus of elasticity  $E = 2.06\times 10^5\text{MPa}$ ,  $W = 6.0\times 10^3\text{mm}^3$ ,  $I = 1.8\times 10^4\text{mm}^4$ ,  $A = 6\times 10^3\text{mm}^2$ . Modulus of elasticity  $E=2.06\times 10^5\text{MPa}$ ,  $W=6.0\times 10^3\text{mm}^3$ ,  $I=1.8\times 10^4\text{mm}^4$ ,  $A=6\times 10^3\text{mm}^2$ . Take the width of the panel as 1m, the panel is subjected to the homogeneous load  $q=F_{\text{max}}\times 1=74.8\text{kN/m}$ , the panel is a multi-span continuous beam, the net span is 0.35m, and the calculation is in accordance with the 3 equal spanning check. The result of internal force calculation is shown in Fig. 3- 5.

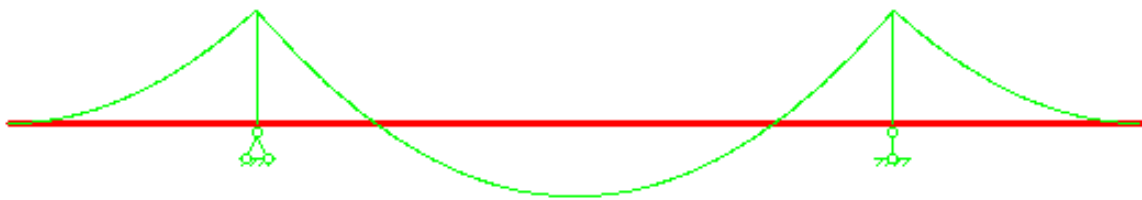

Figure 3. Bending moment envelope diagram.

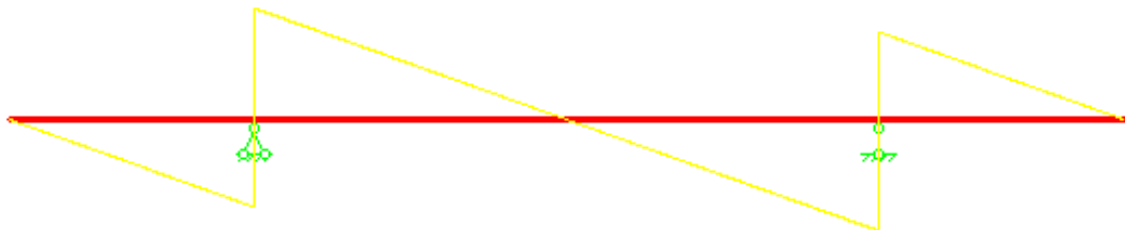

Figure 4. Shear force envelope diagram.

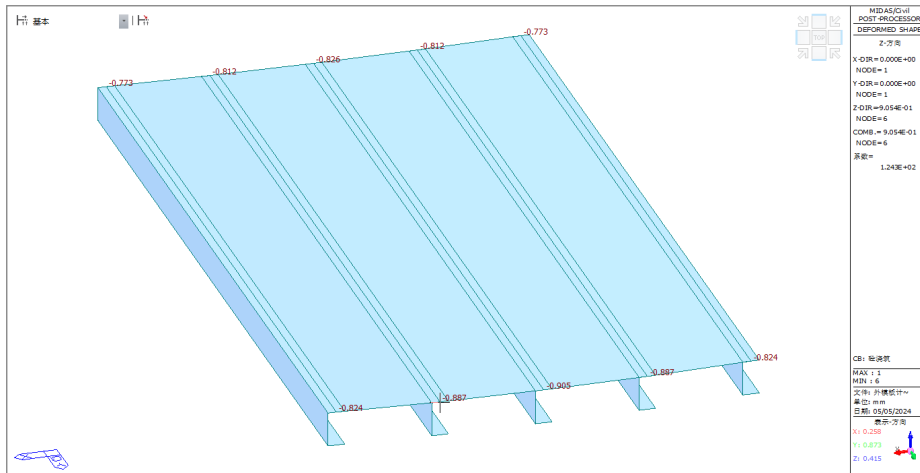

Figure 5. Panel deflection resultant diagram.

Besides, the vertical ribs of the formwork are made of [10 channel steel, the maximum spacing of channel steel is 371mm. after the channel steel, double splicing [14 channel steel back flute is set up, the spacing of back flute is 300mm. the calculation of vertical ribs is carried out by MIDAS CIVIL, and modeling is carried out in accordance with the actual support situation, and the vertical ribs calculation model is made of 273mm +371mm +331mm +301mm + 331mm + 371mm + 273mm double cantilever beam, the calculation model is shown in Figure 3.3. 273mm double cantilever beam, the calculation model is shown in Figure 6 and 7.

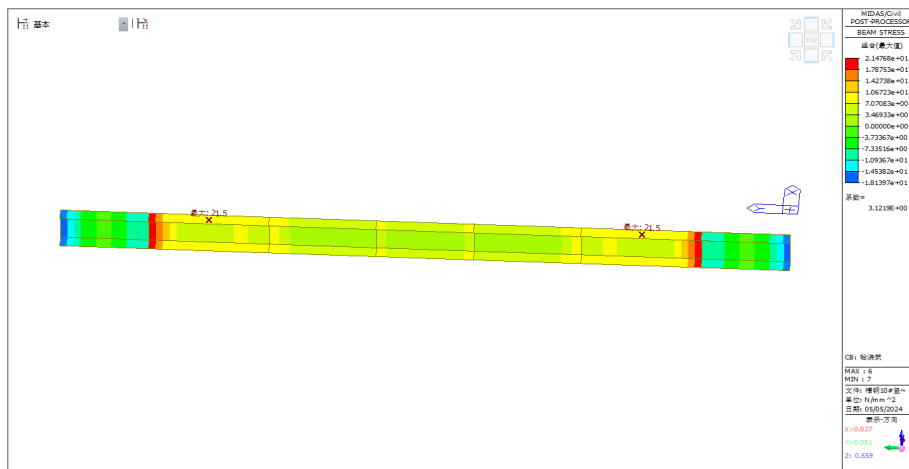

Figure 6. Bending stress diagram of vertical rib

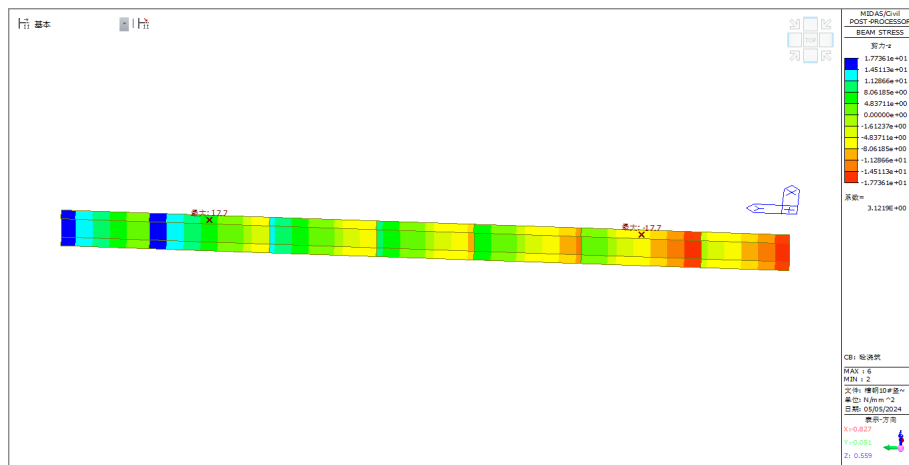
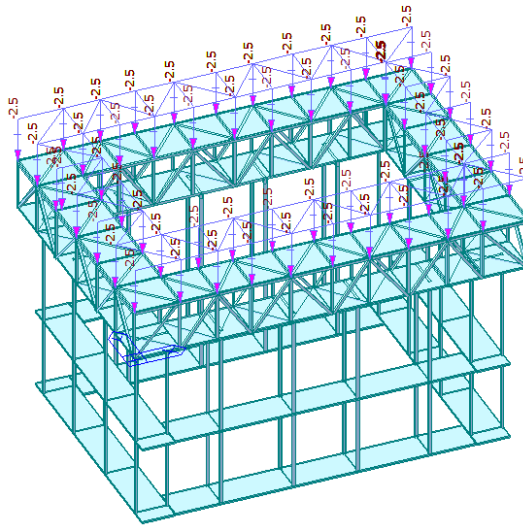

Figure 7. Shear stress diagram of vertical rib

From Figs. 6 and 7, the maximum value of bending stress of vertical rib is  $21.5\text{MPa} < f = 215\text{MPa}$ , which meets the requirement; the maximum value of shear stress is  $17.7\text{MPa} < f_v = 125\text{MPa}$ , which meets the requirement.

1. Standard value of the self-weight of the formwork system (G1K): the standard value of the self-weight of the formwork system is taken according to the actual weight, and the load when the formwork is lifted is borne by the crossbeam of the lifting frame. The standard value of the self-weight of the formwork system (G1K): the standard value of the self-weight of the formwork system is taken according to the actual weight; when the formwork is lifted, the load is borne by the crossbeam of the lifting frame. 2. standard value of self-weight of rack system (G2k): standard value of self-weight of rack system is taken according to the actual weight, and the self-weight of rack system is  $G2k = 100\text{kN}$  (automatically generated by the system when calculating). 3. Standard value of load for construction personnel and equipment (Q1k): the standard value of load for construction personnel and equipment is  $2.5\text{kN/m}^2$ , which is applied to the construction platform panel. 4. Standard value of temporary stacking materials on construction platform (Q2k): the standard value of temporary stacking materials on construction platform is  $2.0\text{kN/m}^2$ , acting on the construction platform panel. Load combination: The load combination when checking the strength of the frame is  $1.2 \times (G1K + G2k) + 1.4 \times (Q1k + Q2k)$ . The load combination for calculating the stiffness of the frame is:  $G1K + G2k$ . The calculation model of the frame system is shown in Fig. 8. Calculate the construction platform as a whole, and the result of its stress is shown in Figs. 9 and 10.



**Figure 8.** Calculation model of the system at the widest part of the rack.

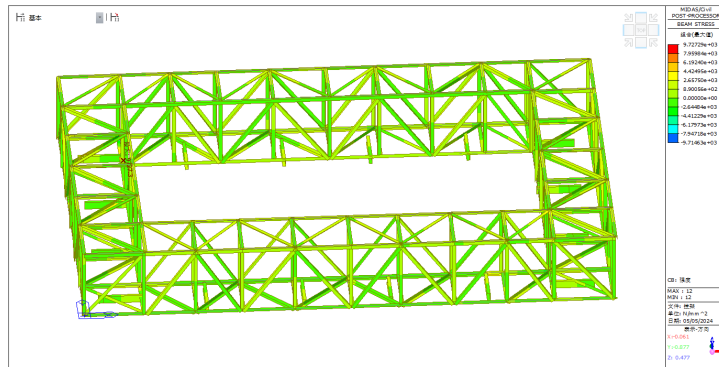

**Figure 9.** Bending stress diagram of construction platform

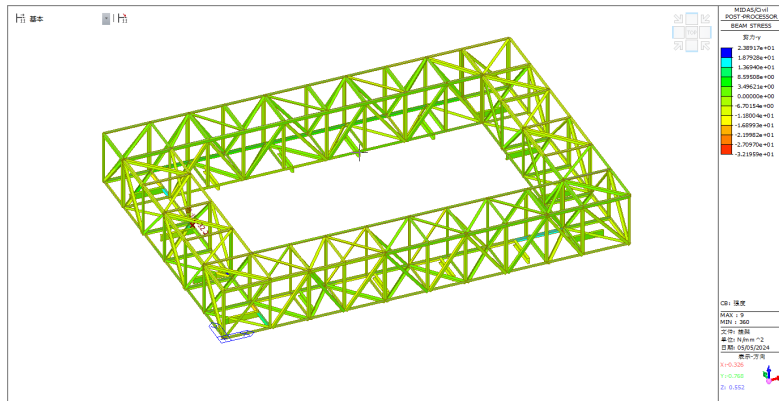

Figure 10. Shear stress diagram of construction platform

Self-weight of the shelf body of the health maintenance platform:  $q_1$  generated by Midas system. Nourishing platform on the construction personnel and equipment load: Nourishing platform on the construction personnel and equipment load  $q_2$  according to the actual situation for the value, each side of the nourishing platform limited to 2 people to carry out construction, a single person's body weight according to the value of 75kg, the equipment to take the value of 50kg, the total weight of the 2 people and the construction equipment is 200kg (2kN). According to the most unfavorable principle, the personnel and equipment loads act in the middle of the perishing platform. The stress results are shown in Figures 11 and 12.

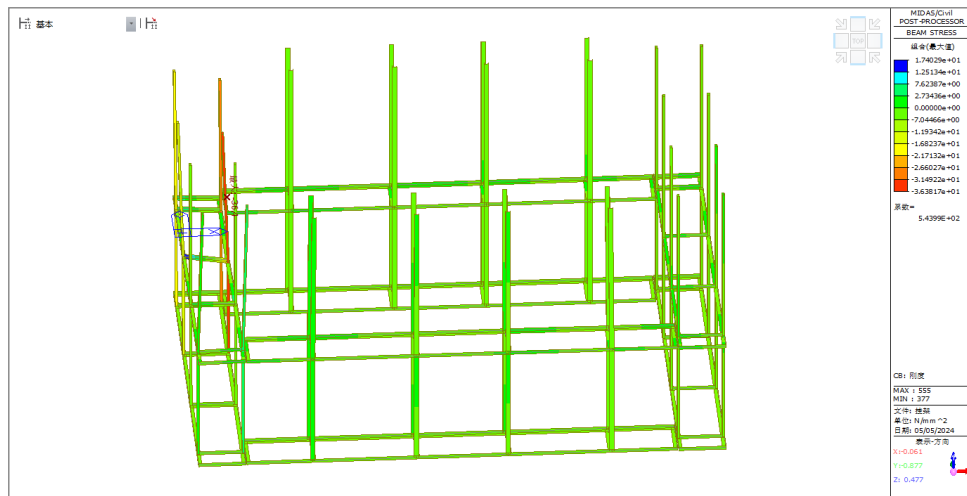

Figure 11. Bending stress diagram of maintenance platform

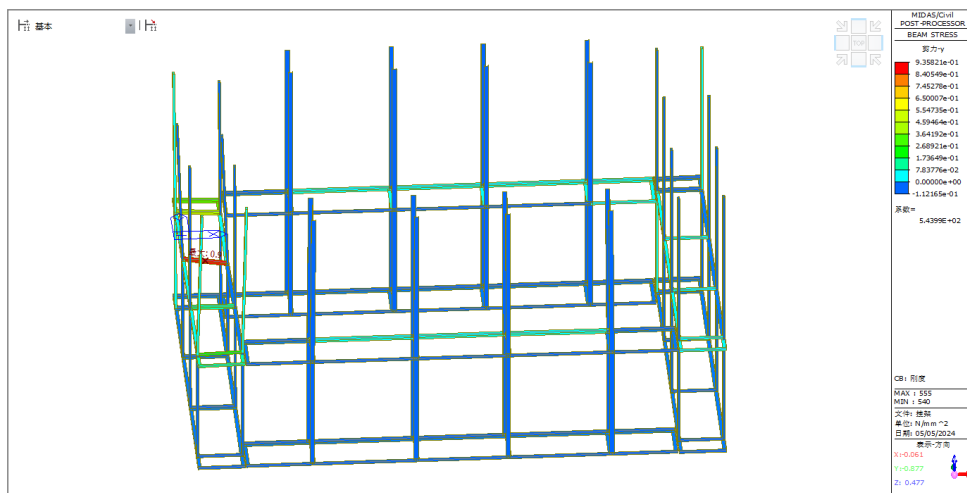

Figure 12. Shear stress diagram of maintenance platform

From the calculation results: the maximum bending stress of the permissive platform:  $\sigma=36.4\text{MPa}<215\text{MPa}$ , to meet the requirements. Shear stress:  $\tau=0.9\text{MPa}<125\text{MPa}$ , meet the requirements.

## 5. Summary

In this paper, the new lifting frame inverted mold structure construction of high piers is studied, and a new type of template structure applicable to thin-walled high bridge piers with variable cross-section is proposed in the background of the actual project, and the finite element method is used to check and analyze the force situation of the overturned mold structure in the construction state, which ensures the construction safety. The result proves that the program is safe and reliable, significantly improves the construction efficiency, shortens the climbing time of the construction platform, and there is no need to penetrate the tensile anchors, which not only simplifies the construction process, but also reduces the cost, and at the same time, solves the difficult problem of the low quality of the appearance of the construction of bridge high pier structure that leads to the impact of the long-term durability.

## Acknowledgements

This work is supported by the Science, Technology and Innovation Project Foundation of Yunling construction co, ltd of YCIC group (YLJS-KF-2024-01) and (YCIC-YF-2021-15).

## References

- [1] Hao Lu,Zhongguo Guan,Jianzhong Li. Effects of higher-order vibration modes on seismic performance of high-pier bridges and their identification [J]. Vibration and Shock, 2012, 31(17): 81-85+98.DOI:10.13465/j.cnki.jvs.2012.17.027.
- [2] Wang Zhenyang,ZHAO Yu,XU Xing. Stability of large-span bridges with high piers[J]. Journal of Chang'an University (Natural Science Edition), 2003,(04):38-40+84.DOI:10.19721/ j.cnki. 1671-8879. 2003. 04.010.
- [3] Li Jianzhong,SONG Xiaodong,FAN Liqi. Discussion on displacement ductility capacity of high piers of bridges[J]. Earthquake Engineering and Engineering Vibration, 2005, (01): 43-48.DOI:10.13197/j.eeev.2005.01.008.
- [4] Liang Zhiyao. Research on the calculation method of displacement ductility capacity of high piers of bridges[J]. Engineering Seismic Resistance and Reinforcement Retrofitting, 2005, (05): 57-62.DOI:10.162 26/j.issn.1002-8412.2005.05.011.
- [5] Xie Sha. Construction technology of high pier columns in bridge engineering[J]. Shanxi Construction, 2018,44(18):152-153.DOI:10.13719/j.cnki.cn14-1279/tu.2018.18.084.
- [6] Cai Fanjie,Hu Houlan. Application of slipform and climbing mold construction process in bridge high pier construction[J]. Highway,2013,(06):68-71.
- [7] Liang Pan. Exploration on optimization strategy of bridge high support formwork design and construction[J]. Urban Construction Theory Research(Electronic Edition),2024,(33):155-157. DOI: 10.19569/j.cnki.cn119313/tu.202433051.
- [8] Li Gong, JIANG Rui, LI Qian. New technology of rapid overturning mold construction for large section of high pier of bridge[J]. Transportation World,2024,(19):115-117.DOI:10.16248/j.cnki.11-3723 /u. 20 24.19.003.