

A Dynamic Monitoring System for The Thermal Conductivity of Transient Hot Wire Liquids

Canyan Yang¹, Shuwei Yang^{1,2,*}, Yihan Wang¹, Xiaoting Qu¹, Yanyi Bian¹, Hengchen Zhao¹, Jinghan Fan¹

¹Intelligent Construction College, Zhengzhou Business University, Zhengzhou 451200, China

²Zhengzhou Intelligent Electromechanical Engineering Research Center, Zhengzhou 451200, China

* Corresponding author

Abstract: In this paper, the thermal conductivity measurement experimental setup built on the principle of transient short filament method was tested using liquid toluene, and the results indicated that the measurements from the experimental setup are accurate and reliable. The thermal conductivity of liquid n-dodecane was experimentally measured within the temperature range of 317.97K to 610.54K and the pressure range of 1MPa to 20MPa. The effective data from the measurements, ignoring the influence of radiation, were fitted into a function related to temperature and pressure. The experimental values were compared with the fitted values, and the relative deviations between the experimental values and the fitted values were found to be mostly within $\pm 2\%$, with the maximum relative deviation being 2.6%.

Keywords: Thermal properties; Thermal conductivity; Transient short wire method; n-Dodecane.

1. Introduction

The scramjet engine, as an intake-type power device, has become a research hotspot worldwide due to its simple structure and the ability to enable aircraft to fly at speeds greater than Mach 5 [1]. When the scramjet engine is operating, it will be subjected to extremely high heat loads, which affect the stable operation of the engine. The regenerative cooling technology is a passive thermal protection method. It not only relies on the physical and chemical heat sinks of the fuel, but also requires good heat transfer capability. And the heat transfer capability is characterized by thermal conductivity.

The thermal conductivity of hydrocarbon fuels is also very important in the transportation, storage, and combustion of the fuels. Currently, there are relatively few direct measurements of the thermal conductivity of hydrocarbon fuels (finished oil), and due to different production processes and crude oil origins, the measured thermal conductivities may vary, lacking universality. There is also an alternative method to directly measure the thermal conductivity of

hydrocarbon fuels, which is to measure the thermal conductivity of the hydrocarbon compounds that make up the hydrocarbon fuels separately, and then calculate the thermal conductivity of the hydrocarbon fuels through the mixing rule based on the known main components of the hydrocarbon fuels. This method has a large workload but is universal.

Tim Edwards [2] provided detailed component compositions of RP-1 and RG-1 through GC/FIMS (gas chromatography - field ionization mass spectrometry). The weight percentages of n-dodecane in RP-1 and RG-1 were 0.687% and 0.075%, respectively. And in these two fuel components, n-dodecane had the highest weight percentage among the normal alkanes. Obviously, n-dodecane has certain contribution and value. This paper measured the liquid phase thermal conductivity of n-dodecane and has important academic value and engineering application significance for the development of new fuels and the improvement of engine performance.

2. Experimental Principle and Thermal Conductivity Measurement System

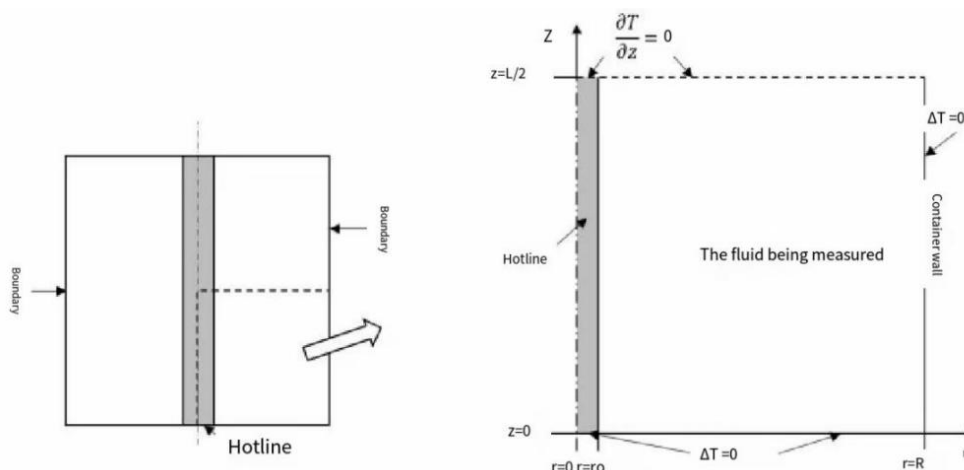

Figure 1. Experimental physical model

(1) Experimental Principle

The thermal conductivity measurement experimental platform used in this paper is built based on the principle of the transient short wire method. The transient short wire method was initially proposed by the Japanese scholar Fujii [3], which is a method combining experimental measurement and numerical solution[4]. The physical model of the experiment is shown in Fig1. During the entire measurement process, the hot wire is in a central symmetrical state in the

container. Therefore, only a quarter of the entire physical model can be taken for analysis.

(2) Thermal Conductivity Measurement System

As shown in Fig. 2, the entire thermal conductivity measurement system consists of the thermal conductivity measurement device, the data acquisition system[5], the temperature control and measurement system, the pressure measurement system, and the vacuum system.

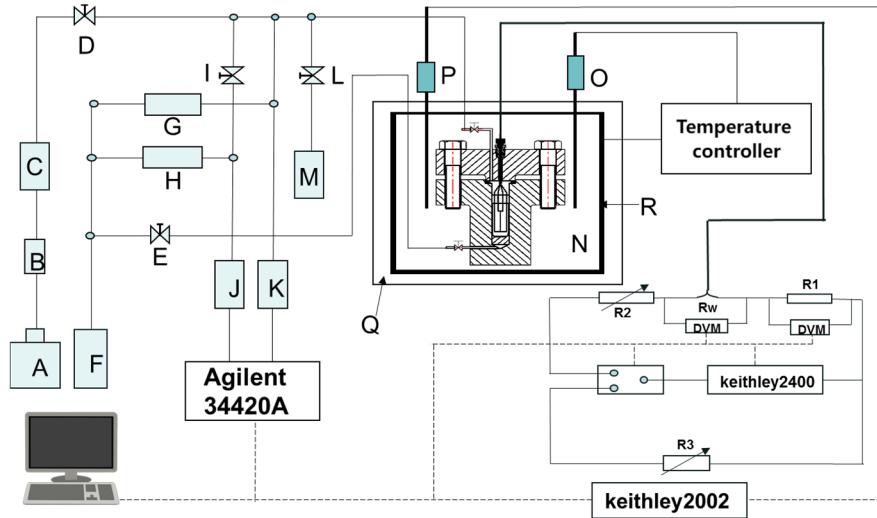

Figure 2. Schematic diagram of the thermal conductivity measurement system

A: Sample fluid; B: Filter valve; C: High-pressure pump; D, I, L: Shut-off valve; E: Pressure relief valve; F: Recovery tank; G: High-pressure safety valve; H: Low-pressure safety valve; J: Low-pressure sensor; K: High-pressure sensor; M: Vacuum pump; N: High-temperature constant temperature bath; O: PT100; P: First-class standard platinum resistance thermometer; Q:Insulation layer; R: Heating plate

The thermal conductivity measurement device of this article is shown in Fig.3. The structure of this measurement device is cylindrical and the material used is 316 stainless steel. It adopts a flange and bolt sealing structure. In the figure, 7, 8, 9, and 10 belong to the core measurement device. Quartz

fixtures are used to fix a platinum rod with a diameter of 1 mm, and a point-welding method is used to weld a platinum wire with a diameter of 0.025mm at the center of the two platinum rods.

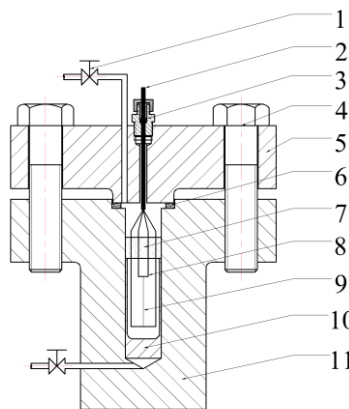

Figure 3. Thermal Conductivity Measurement Device

1: Valve; 2: Wires; 3: Wire sealing component; 4: Bolt; 5: Flange; 6: Copper seal gasket; 7: Quartz fastener; 8: Pt rod; 9: Pt hot wire; 10: Support cylinder; 11: Pressure vessel body.

The data acquisition system in this article is the core component. As shown in Fig. 4, a platinum wire, a standard resistor, a variable resistor box, and a power meter constitute a series circuit. The Keithley 2400 power meter and the Agilent 34410A digital multimeter are all connected to the industrial computer via GPIB cables, and the power meter and

the digital multimeter are connected through a trigger line. Before the formal measurement experiment, the resistance value of the variable resistor box needs to be adjusted so that the sum of its resistance value and the resistance value of the standard resistor is approximately the same as the initial resistance of the platinum wire. This ensures that the electric

heating power through the platinum wire remains basically constant during the measurement process.

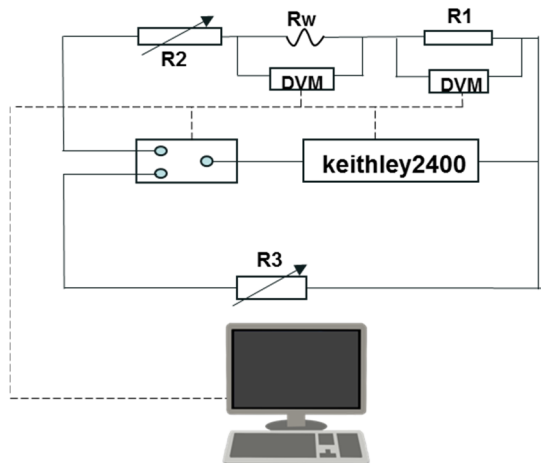

Figure 4. Data Acquisition System

Rw: Heating wire resistor; R1: Standard resistor; R2, R3: Variable resistors; DVM: Agilent 34410A digital multimeter

The constant temperature system adopted in this article is a large-capacity high-temperature and high-precision constant temperature bath using air as the medium, with a temperature control accuracy of $\pm 10\text{mk}/20\text{min}$ [6]. The pressure measurement system is divided into a high-pressure measurement system and a low-pressure measurement system to achieve segmented pressure transmission measurement.

3. Inspection of the Experimental System

For this experimental system, an initial liquid phase toluene

with a purity of 99.5% was experimentally verified within a temperature range of 317.44K to 635.82K. The critical temperature of toluene is 591.79K. Fig.5-1 Fig.5-2 and presents the distribution maps and relative deviation graphs of the thermal conductivity of toluene according to isobaric lines and isothermal lines. From Fig.5-3 and 5-4, it can be seen that the relative deviation of the thermal conductivity of toluene from NIST is within $\pm 3\%$, with the maximum deviation being -3.75% , indicating that this experimental system is accurate and reliable.

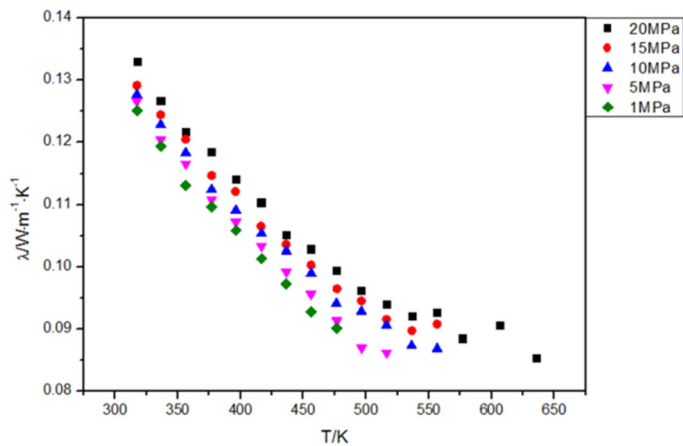

Figure 5-1. Distribution map of toluene thermal conductivity according to isobaric lines

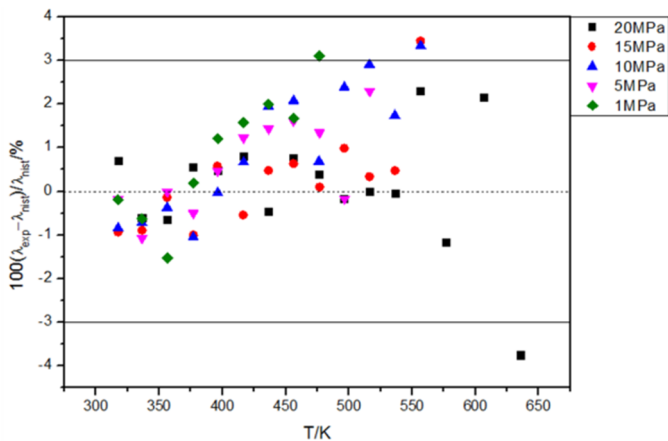

Figure 5-2. Relative deviation of toluene thermal conductivity from NIST data

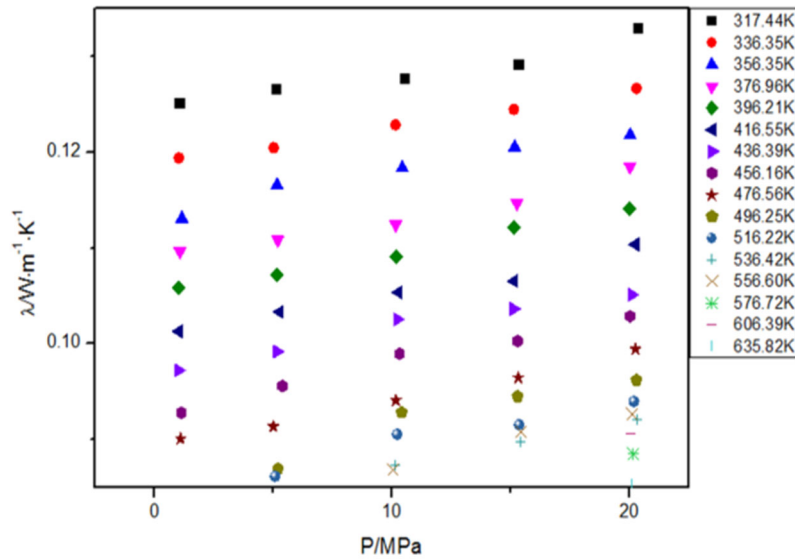

Figure 5-3. Distribution map of toluene thermal conductivity according to isothermal lines

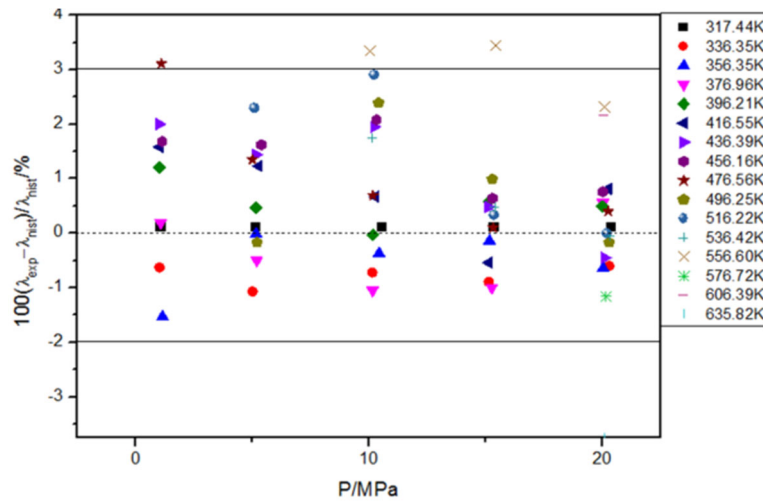

Figure 5-4. Relative deviation of toluene thermal conductivity from NIST data

4. Experimental Measurement of the Liquid Phase Thermal Conductivity of Tetradecane

Using the measurement system of this experiment, the liquid phase thermal conductivity of n-dodecane was measured. The temperature range was from 317.97K to 610.54K, and the pressure range was from 1MPa to 20MPa. A total of 159 thermal conductivity data along 13 isothermal

lines were obtained. The results are listed in Table 3-2. The thermal conductivity data obtained were fitted to a relationship between temperature and pressure, and the formula is as follows:

$$\lambda/W/m/K = \sum_{i=0}^3 \sum_{j=0}^3 \alpha_{ij} (T/K)^i (p/MPa)^j \quad (1)$$

The values of each coefficient in this equation are shown in Table 1:

Table 1. Coefficient Values of the Fitting Relationship Equation

a_{ij}	$j=0$	$j=1$	$j=2$	$j=3$
$i=0$	0.15528	0.0069	3.74E-04	-1.92E-05
$i=1$	1.26E-04	-5.29E-05	-2.46E-06	1.40E-07
$i=2$	-1.01E-06	1.41E-07	4.80E-09	-3.18E-10
$i=3$	9.65E-10	-1.18E-10	-2.92E-12	2.32E-13

Table 2. Data on the Liquid Phase Thermal Conductivity of n-Dodecane

T/ K	p/ MPa	λ / $W \cdot m^{-1} \cdot K^{-1}$	T/ K	p/ MPa	λ / $W \cdot m^{-1} \cdot K^{-1}$	T/ K	p/ MPa	λ / $W \cdot m^{-1} \cdot K^{-1}$
317.97	21.06	0.13498	479.79	15.27	0.09926	550.49	20.26	0.09239
317.98	21.06	0.13256	479.67	15.27	0.10016	550.64	15.16	0.0905
318	15.79	0.13031	479.76	10.3	0.0963	550.9	15.16	0.08992
317.97	15.79	0.13115	479.84	10.3	0.09592	550.74	15.16	0.08999
318.06	10.74	0.12884	479.86	10.3	0.09675	550.79	10.16	0.08791
318.1	10.74	0.12863	479.99	5.33	0.09464	550.82	10.16	0.08854
318.23	5.3	0.12625	480.1	5.33	0.09382	550.85	10.16	0.08756
318.19	5.3	0.12672	480.03	5.33	0.09412	551.04	5.25	0.08451
318.27	1.22	0.12511	480.2	1.65	0.09143	550.96	5.25	0.08389
318.33	1.22	0.12522	480.15	1.65	0.09086	550.87	5.25	0.08475
347.83	19.78	0.12591	480.12	1.65	0.09091	551.27	1.24	0.08128
347.85	19.78	0.12539	489.39	21.71	0.1011	551.27	1.24	0.08139
347.92	15.16	0.12423	489.47	21.71	0.1018	569.81	20.18	0.08957
347.95	15.16	0.12262	489.59	15.02	0.09854	569.96	20.18	0.08845
347.87	10.81	0.12201	489.39	15.02	0.0975	569.9	20.18	0.08788
348.01	10.81	0.12082	489.61	15.02	0.09864	570.19	15.12	0.08539
347.99	5.12	0.1199	489.65	10.62	0.09581	570.07	15.12	0.0857
348.04	5.12	0.11906	490.06	10.62	0.09498	570.02	15.12	0.08547
348.07	1.1	0.11708	490.08	10.62	0.09421	570.25	10.09	0.08251
348.07	1.1	0.11728	490.15	5.21	0.09077	570.18	10.09	0.08196
378.51	19.92	0.11965	490.14	5.21	0.09118	570.12	10.09	0.08292
378.6	19.92	0.11935	490.07	5.21	0.09257	570.28	5.19	0.07888
378.71	15.15	0.11734	490.22	1.13	0.08859	570.3	5.19	0.07959
378.69	15.15	0.11768	490.34	1.13	0.08875	570.19	5.19	0.07992
378.8	10.64	0.1152	490.29	1.13	0.08899	570.21	1.2	0.07821

Fig.6-1 shows the variation of thermal conductivity of n-dodecane along 5 isobaric lines with temperature. Fig.6-2 presents the relative deviation of the experimental thermal conductivity of n-dodecane from the calculated thermal conductivity according to Equation (3-1). From Figure 6-2, it

can be seen that the relative deviation between the experimental thermal conductivity and the calculated thermal conductivity based on the fitting formula is basically within 2%, with an average relative deviation of -0.0082% and the maximum relative deviation of 2.6%.

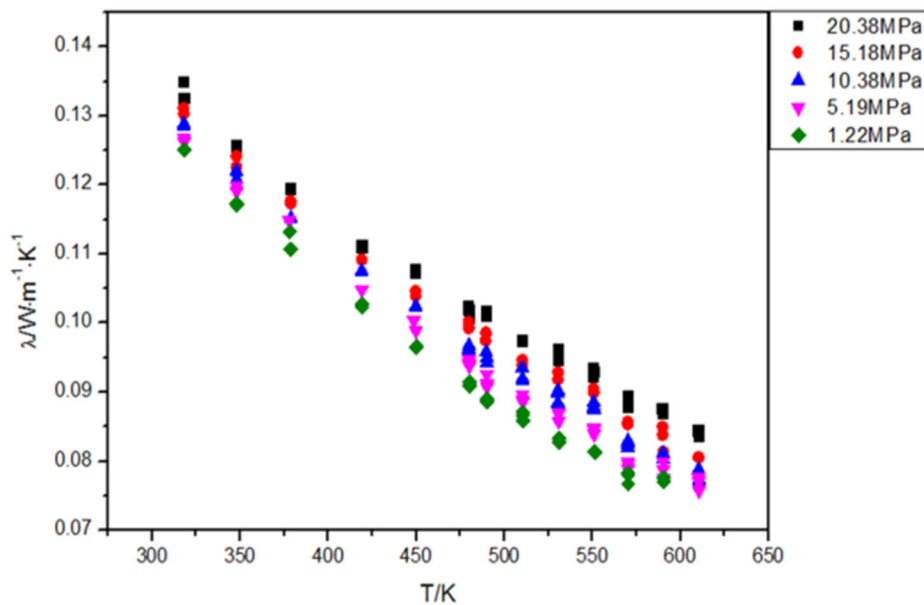
**Figure 6-1.** Graph showing the variation of the thermal conductivity of n-decane with temperature

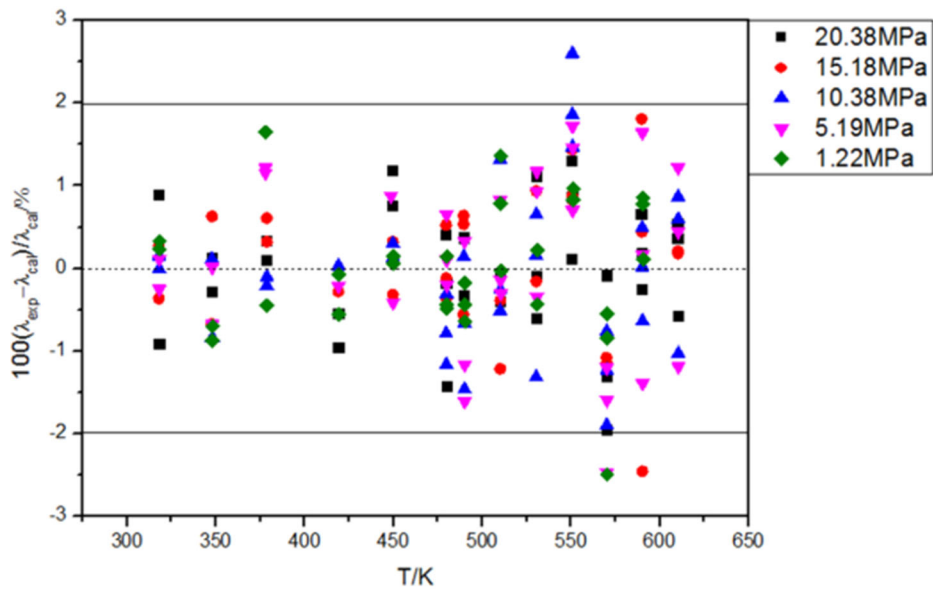

Figure 6-2. Graph showing the relative deviation between the experimental values and the fitted values

5. Summary

The experimental platform was improved based on the original design, making it more convenient for filling and exchanging working fluids. The liquid-phase toluene was used to test the thermal conductivity measurement experimental platform built based on the transient filament method. The results showed that the measurement results of this experimental platform were accurate and reliable.

Experiments were conducted to measure the liquid-phase thermal conductivity of n-dodecane within the temperature range of 317.97K to 610.54K and the pressure range of 1MPa to 20MPa.

Acknowledgements

This research was supported by The Undergraduate Innovation Key Program in 2025(No.240084470105), Henan Science and Technology Attack Project (No. 252102230094).

References

- [1] Xia Youcai, Dai Shun'an, Su Yan. Research Status and Trends of Superalloy Ramjet Engines [J]. Journal of Aeronautical Missiles. 2016(08): 59-63.
- [2] Edwards T. "Kerosene" Fuels for Aerospace Propulsion - Composition and Properties[J].38th AIAA/ASME/SAE/ASEE Joint Propulsion Conference & Exhibit. 2002.
- [3] Fujii M, Zhang X, Imaishi N, et al. Simultaneous measurements of thermal conductivity and thermal diffusivity of liquids under microgravity conditions[J]. International Journal of Thermophysics, 1997, 18 (2): 327-339.
- [4] Zeng Fanjian. Development of a Thermal Conductivity Measurement System Using the Transient Short Wire Method [D]. Xi'an: Xi'an Jiaotong University, 2013.
- [5] Healy JJ, De Groot JJ, Kestin J. The Theory of the Transient Hot-Wire Method for Measuring Thermal Conductivity[J], Physica, 1976, 82: 392-408.
- [6] Marcia L. Huber ,* Arno Laesecke , and Richard Perkins. Transport Properties of n-Dodecane[J]. Energy Fuels, 2004, 18 (4), 968–975.