

Design and Implementation of Numerical Control Yarn Stranding and Binding Machine

Zhelu Wang^{1, a}

¹Wenzhou Polytechnic, Wenzhou 325035, China

^a382211678@qq.com

Abstract: Yarn stranding and packaging machinery has always been a special mechanical equipment with high technical requirements and large cross industries in the light textile packaging industry. In order to realize the automatic stranding and packing of small batch yarn, the automatic stranding and packing system is designed according to its working principle, and the control system is designed based on smc6480 controller, and its software is used for programming. The experimental research shows that the control system of this project runs well, which is conducive to cost saving and function expansion of the subsequent sequence.

Keywords: Numerical control, Yarn stranding, Binding machine, Smc6480 controller.

1. Introduction

At present, the yarn stranding and packaging machinery has always been a special mechanical equipment with high technical requirements and large cross industries in the light textile packaging industry. At present, the winches on the market are mainly for silk suppression factories and textile printing and dyeing factories. They are mainly used to change the yarn packaging form and meet the production process requirements. However, there are few winches for personal small twisted goods with the characteristics of small batch and multiple varieties in the domestic market. Now, the common practice is to complete them through manual subcontracting. The labor is boring, the efficiency is low, the quality can not be guaranteed, and it can not meet the worldwide DIY trend. At present, only a few professional manufacturers in France and other countries have developed and equipped this kind of mechanized equipment with personalized small batch stranding and binding. Moreover, such equipment can not be purchased in the market and only undertake processing services. Therefore, it is difficult for domestic manufacturers of the same kind to compete with them [1-2].

At present, there are a large number of small handicrafts and commodity industries in Zhejiang Province, which are mainly manual operations from processing to packaging. The project aims to realize the automatic packaging of embroidery yarn in large quantities and small packages, provide reference for improving the automatic packaging of similar small soft goods, and improve the automatic production level of typical industries in small towns in Zhejiang Province [3-4].

At present, the automatic yarn stranding machine is mainly large-scale stranding machine, and its product packaging form is to meet the use of large-scale industrial looms. At present, the manual cross stitch yarn is in the form of small packaging. The yarn length of a small packaging is less than 8m, and the diameter of the yarn roll after binding is not more than 8mm. The product sample is shown in Figure 1. At present, this kind of product packaging is mainly realized in small factories in villages and towns and families by means of recording pieces. Among them, Yiwu and other regional

economies developed from small commodities are the main characteristics. Manufacturers are in urgent need of automatic machinery that can meet the packaging of this kind of soft goods.



Figure 1. Cross stitch small yarn roll

On the basis of the research on the original skein machine, this project deeply carries out the design of the automatic skein binding machine with small skein as the object. Through the development and industrial application of the miniaturization of the skein forming system, the binding machine actuator, the binding structure, and the multi head CNC system, it has an important impact on and plays a significant role in promoting the automation, product grade, and technological innovation of small commodity production in Zhejiang Province. Some key technologies obtained after the completion of the project will also promote the upgrading of the products of the province's software packaging industry and have an important impact on its technological innovation.

2. Working Principle and Design of Numerical Control Yarn Stranding and Binding Machine

2.1. Overall Design of Numerical Control Yarn Stranding and Binding Machine

The CNC yarn stranding and binding machine is generally composed of yarn guiding mechanism, yarn arranging mechanism, yarn winding mechanism, yarn breaking clamping mechanism and binding mechanism. The key

structure design of the technology is that the yarn arrangement mechanism mainly adopts the X, y and Z-direction motion platform to realize the yarn arrangement, while the yarn winding mechanism adopts the multi axis linkage transmission design to achieve the yarn winding design. The binding mechanism mainly adopts the flexible packaging of precision manipulator. These mechanisms are an important part of the whole mechanical structure, and their design and research have a great impact on the later experiments. The overall structure of the stranding and binding machine is shown in Figure 2.

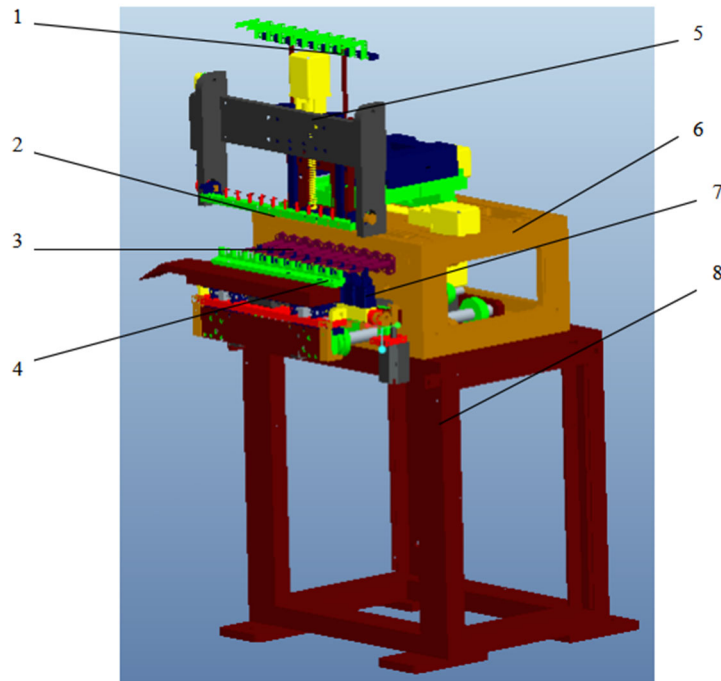

1-yarn guide mechanism; 2- yarn arrangement mechanism; 3- winding mechanism; 4-discharge mechanism; 5-x, y, Z-direction motion platform; 6- headstock; 7- cut off the clamping mechanism; 8-shelf

Figure 2. Overall mechanism diagram of stranding and binding machine

2.2. Structural Design of Main Components

2.2.1. Design of Yarn Arrangement Mechanism

The design of the yarn arrangement mechanism mainly includes two parts: the x, y, z direction motion mechanism and the yarn hook angle mechanism, so as to realize the uniform arrangement of the yarn.

(1) XYZ-direction motion mechanism

The XYZ direction motion mechanism constitutes a standard three-axis servo system, so that the needle nozzle can move freely, and the winding action can be carried out freely according to the program. In addition, the needle nozzle can also change different angles according to the cylinder actuator. When the four cylinders are in the extended state, the needle nozzle faces inward and is parallel to the ground plane; When the upper cylinder retracts, the needle nozzle rotates 90° , and the needle nozzle faces down and is perpendicular to the ground. When the lower cylinder also retracts, the needle

nozzle continues to rotate by 30° and forms a 120° angle with the ground. To correspond to yarn terminals in different directions.

(2) Hook wire angle mechanism

The hook wire corner part is clamped on the guide strip by the guide groove cover plate and the guide seat through the knob. The guide bar is marked with a scale, and different twisting lengths can be selected by adjusting the front and rear positions of the hook wire angle components in the twisting mechanism. The hook wire angle part is powered by the air cylinder and drives the hook wire plate to rotate through the connecting rod mechanism, so that the hook wire needle installed on the hook wire plate can move up and down to complete the hook and separation of the electromagnetic wire.

According to the above theoretical analysis, we designed the drawing, and used pro/e to carry out three-dimensional modeling, and then assembled it. The final three-dimensional design drawing is shown in Figure 3.

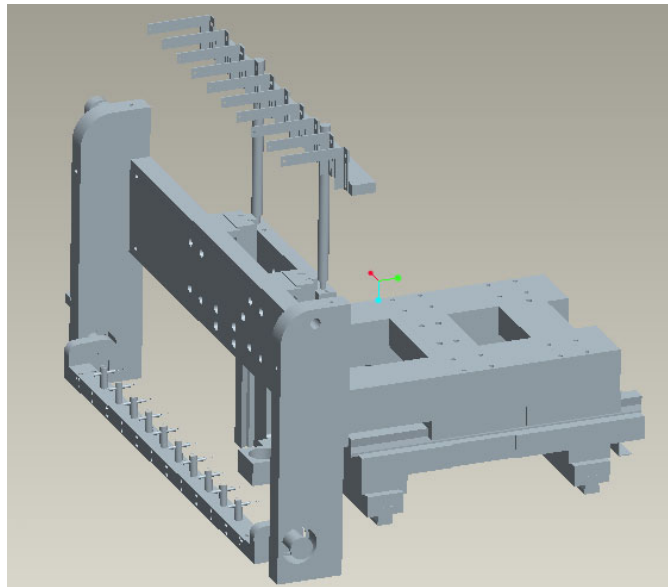

Figure 3. General assembly drawing of wiring arrangement mechanism

2.2.2. Design of Winding Mechanism

The winding mechanism plays a very important role in the take-up and arrangement of wires. The wire, strand and rope are evenly and densely wound on the take-up I-wheel through the periodic back and forth movement of the winding mechanism. In the long development process of metal products industry at home and abroad, people have successively adopted mechanical, hydraulic pneumatic and electric wire arrangement mechanisms in practice. Although they have similar points, their structure and working principle determine their congenital differences.

For the multi axis linkage transmission part of the binding machine, the servo motor or stepping motor is used to drive the rotation of multiple winding shafts synchronously. This scheme can better ensure the constant speed and high-speed demand of the winding shaft, and can realize high-speed winding. As shown in Figure 4, it is a three-dimensional diagram of the designed multi axis linkage winding. The winding efficiency is improved through multi axis linkage, which brings convenience to production.

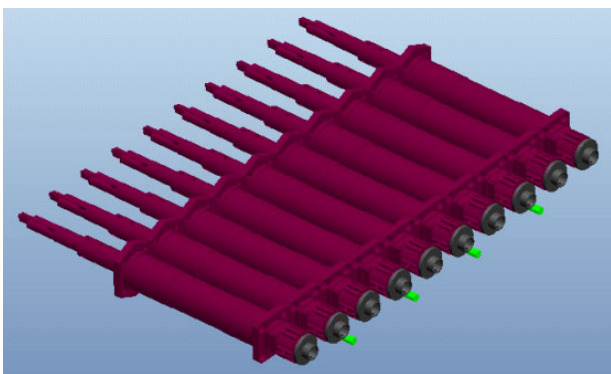

Figure 4. Multi axis linkage yarn winding transmission components

Install the key components to complete the small hank in front of each shaft of the multi shaft transmission system, as shown in Figure 5. According to the manufacturer's requirements for the small hank, we can independently design the size of the small hank components, and finally take them out from the gap on both sides through the micro precision manipulator to realize the automatic sliding of the hank.

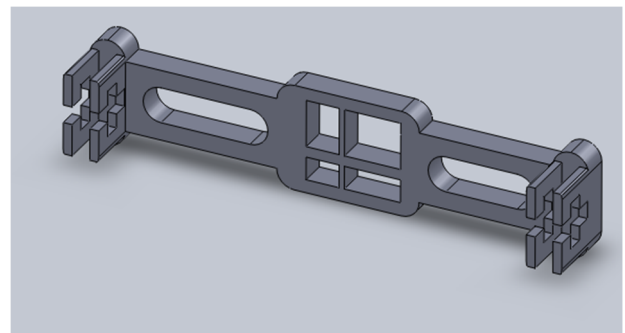
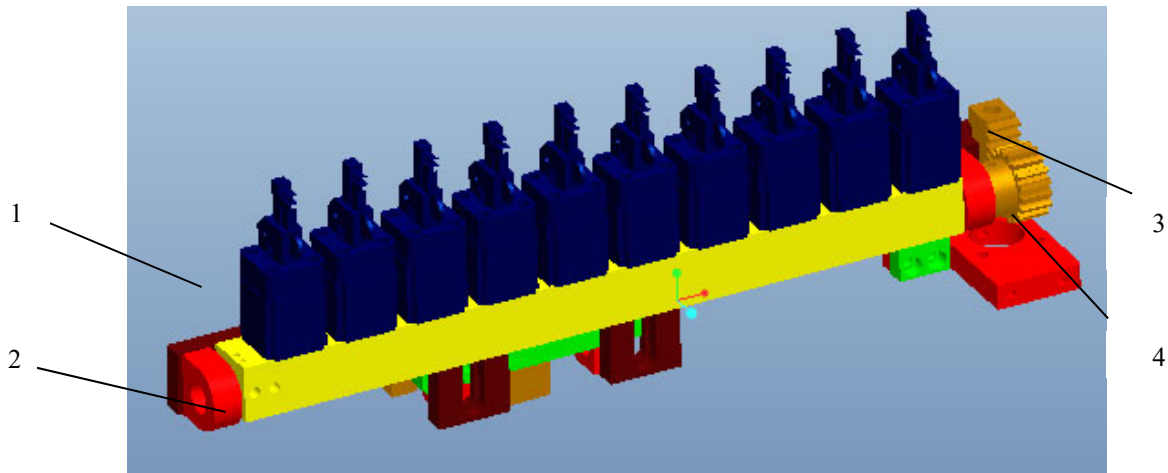

Figure 5. Key components of small stranding

2.2.3. Design of Wire Breaking Clamping Mechanism

The design of the thread breaking clamping mechanism is a mechanism for clamping and cutting yarn, which is composed of a yarn breaking clamping device installed on one side of the winding machine. The device comprises a mounting plate, on which is a row of clamping mechanisms, which are driven by rotating gears, the gears are matched with racks, and the racks are driven by air cylinders. The other side is provided with a cutting knife and a clamping plate which are parallel to each other and can slide respectively. When in use, move the air cylinder, rotate the hook to pull the yarn, and cooperate with the sliding of the clamping plate to clamp the yarn. At this time, the cutter slides down to cut the yarn. Figure 6 is a three-dimensional view of the designed wire breaking clamping mechanism.



1-cylinder 2-mounting plate 3-rack 4-gear
Figure 6. Cutting clamping mechanism

Through the design of automatic winding system, multi axis winding transmission components and cutting clamping mechanism, we have preliminarily completed the design of self-adaptive following system for stranding and realized the key design of automatic stranding.

2.2.4. Binding Mechanism

The binding mechanism is an important part in our design, so we designed a precision binding mechanism, as shown in Figure 7. After the automatic stranding of the winding

mechanism, we need to wrap the stranding. First, we run the binding groove to the lower part of the stranding head through cylinder 1. Then, the air cylinder 2 drives the hooking mechanism to one side of the skein, and then the air cylinder 3 hooks the skein through the gap at both ends, so that the skein falls on the groove paved with soft packaging, and the two sides of the groove realize the combination of soft packaging. The whole process is driven by the precision cylinder, which is closely followed step by step, and we have high requirements for the precision of the execution end.

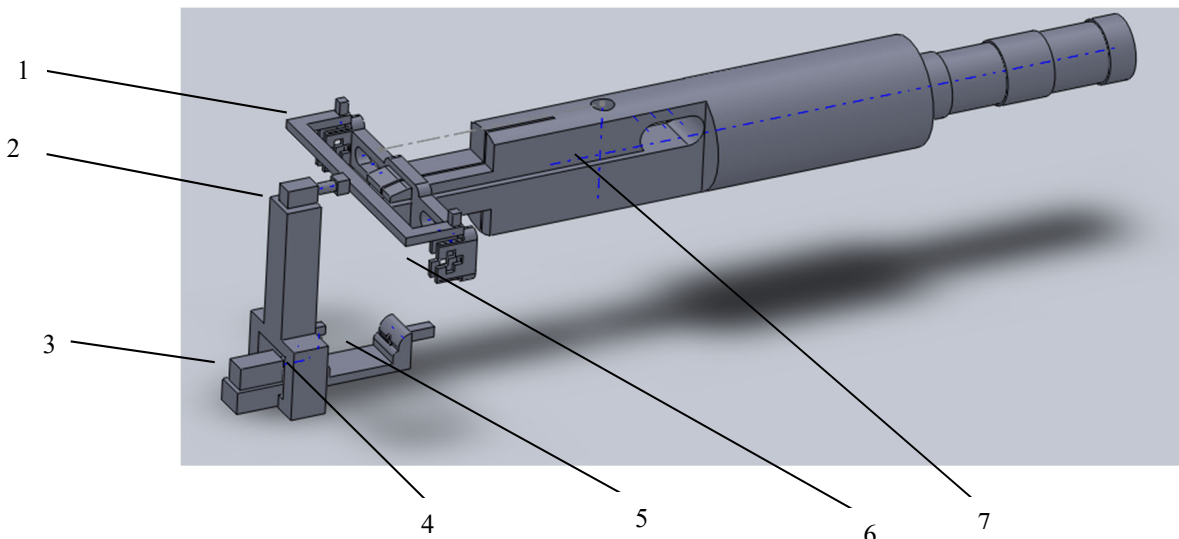

1-cylinder 3 2-cylinder 2 3-cylinder 1 4-groove 5-glue spray port 6-yarn strander 7-shaft
Figure 7. Binding mechanism

3. Design of the Control System of the Numerical Control Yarn Stranding and Binding Machine

3.1. Function Analysis of Control System

In the NC yarn stranding and binding system, the control system is responsible for information processing and commanding the operation of the whole system. Whether the information processing is correct and timely directly affects the quality and efficiency of the system work. The CNC yarn stranding and binding machine mainly includes yarn guide,

yarn arrangement, yarn winding, yarn breaking clamping, binding, etc. all parts must coordinate under the unified command of the controller to complete the grafting task. As a complete control system, the controller shall also have basic functions such as start, stop, pause and reset.

3.2. Selection of Controller

Smc6480 controller is a general-purpose independent motion controller based on 10/100m Ethernet. It can support multiple controllers and PCs to form a control network. The number of controllers in the network is unlimited; It can also be used in various occasions where offline operation is

required.

The controller can control four stepping or servo motors, and has advanced functions such as maximum 5MHz pulse frequency, four axis linear interpolation, two axis arc interpolation, continuous curve interpolation, S-shaped curve speed control, etc. Smc6480 is based on the hardware structure of embedded processor and FPGA. The interpolation algorithm, output of pulse direction signal, automatic speed up and down processing, origin and limit signal detection and processing are all realized by hardware, ensuring the high speed, high precision and system stability of high-performance motion control. A stable and reliable high-speed continuous trajectory motion control system can be developed through simple programming.

3.3. Design of Control Program

Motion6480 is a debugging software provided by Leitai company for users. With this software, users can not only be familiar with the software and hardware functions of the smc6480 controller quickly, but also test the performance characteristics of the control system when it performs various movements conveniently and quickly.

After starting motion6480, first enter the main interface. The startup window, namely the main interface, is shown in Figure 8. Before clicking the "connect serial port" or "connect network" button, please confirm that the smc6480 controller has been connected to the PC through the serial port or network port. When network connection is adopted, ensure that the IP of the controller has been configured in a network segment of the PC.

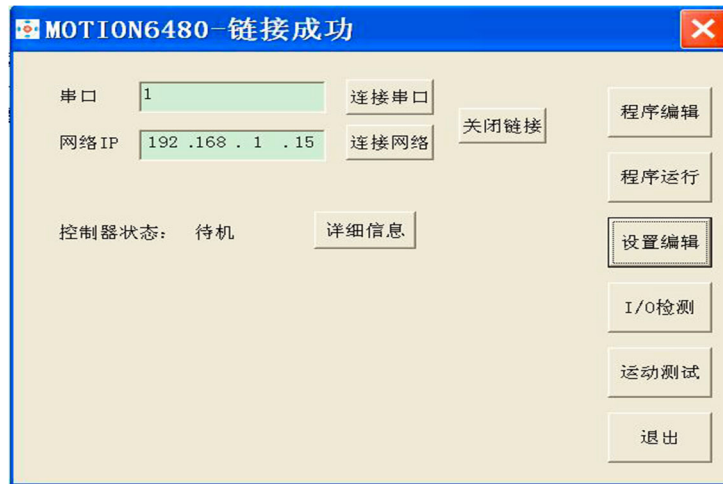

Figure 8. Startup interface

Then click the "i/o detection" button in the main interface to pop up the "i/o detection" interface and set its input and output ports.

Finally, click the "motion test" button in the main interface to pop up the "motion test" interface, as shown in Figure 9. The functions that can be realized in this interface are: point

motion, zero return (zero return motion), linear interpolation, arc interpolation, modifying the current coordinates, and manual testing.

In program design, we will generate NC code, as shown in Figure 9. The specific program is attached.

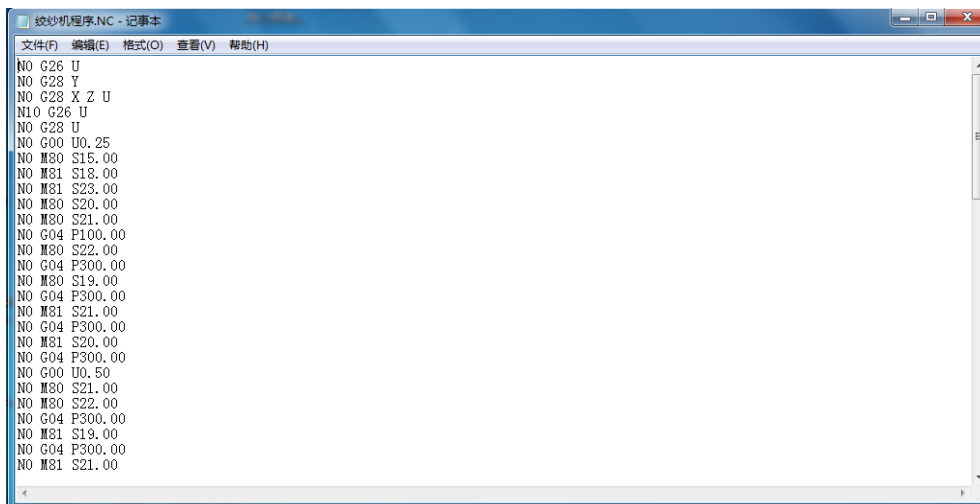

Figure 9. NC code

The final design of the control system is shown in Figure 10.

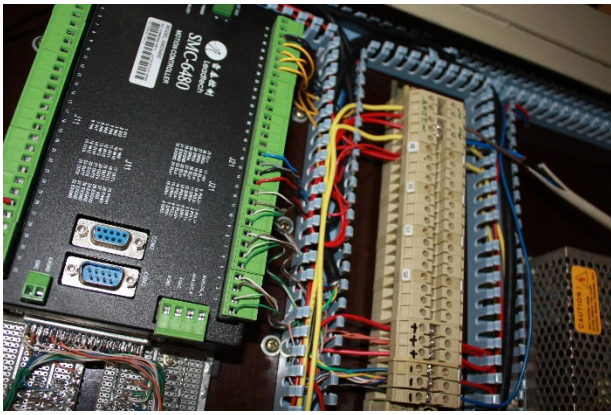

Figure 10. Physical diagram of control system

4. Conclusion

This project analyzes the research status of NC yarn stranding and binding at home and abroad. In view of the current manual cross stitch yarn, we have developed our own numerical control stranding and binding machine. The machine mainly includes a yarn guide mechanism, a winding mechanism, a multi axis linkage winding mechanism, an automatic cutting and clamping mechanism, a binding mechanism and a discharging mechanism, so as to realize the whole process of twisting. The project uses smc4860 to control the yarn strander, which shortens the development

cycle, improves the reliability of the control part, saves costs, runs well, and is conducive to the functional expansion of the subsequent sequence.

Acknowledgment

This work was supported by the Ministry of education supply and demand docking employment and Education Project No. 20220100911, the special research project of Higher Vocational Education in Wenzhou Polytechnic No.WZYGJzd202002,the special project of "Research on Higher Vocational Education" of China Association of Higher Education No.2020GZYB29.

References

- [1] zhangguozhu. Development of fancy yarn woven products [c]// Proceedings of the 16th National Symposium on fancy yarn and fabric technology progress [publisher unknown], 2010:143-145.
- [2] Shangjihui Research on control system of fancy yarn machine [d] Donghua University, 2008.
- [3] Yaohongxing Development and domestic development prospect of hollow spindle fancy yarn machine [j] Foreign textile technology (textile volume), 1988 (10): 3-4+6.
- [4] yaohongxing New fancy yarn machine fm-fx[j] Foreign textile technology (textile volume), 1988 (08): 46+20.