

Construction Technology and Engineering Application of Post Installation of Concrete Decorative Lines on Building Facades

Wei Yuan, Dajiang Geng*, Jianqiu Che, Renhong Sun, Pengju Zhang

China Construction 4th Engineering Bureau 6th Corp.Limited, Shanghai, 201100, China

* Corresponding author: Dajiang Geng (Email: gjd1410704@alumni.tongji.edu.cn)

Abstract: For the consideration of beautiful appearance of building facades, many building facades are designed with reinforced concrete lines. The traditional building facade concrete decorative line needs secondary pouring construction, which has the problems of complex construction process, low construction precision, high construction cost and poor construction quality. This paper presents a construction method of post installation of concrete decorative lines on building facades. Firstly, the principle of post installation of concrete decorative lines on building facades is clarified by theoretical analysis method, then the design and calculation method of decorative lines is clarified by mechanical analysis method, and then the specific construction process of decorative lines is clarified in combination with the on-site construction process. Finally, the post installation construction technology of concrete decorative lines on building facades is applied to a project example, and the economic analysis is carried out. The results show that the post installation of concrete decorative lines on the building facade is mainly based on the construction principle of prefabricated installation; The stress analysis of decorative lines needs to focus on the strength of the connectors between the lines and the building structure; Compared with the traditional secondary pouring construction method of decorative lines, the post installation construction method can save about 30% of the cost, and the construction process is more safe and efficient, with higher construction precision and quality. It is suggested that it can be popularized and applied in similar projects.

Keywords: Concrete decorative line, Post installation, Principle analysis, Engineering application.

1. Introduction

With the gradual improvement of people's aesthetic needs, the building facade modeling is becoming more and more novel, and it is more and more common to set concrete decorative lines on the building facade. How to ensure the construction quality of setting concrete decorative lines on the building facade undoubtedly has very important engineering practical significance. At present, the secondary pouring method is often used in the actual site construction when setting concrete decorative lines on the building facade [1]. The full length of the concrete decorative line in the general design drawings is designed in the middle of the beam or shear wall, which generally cannot be poured together with the main body of the building structure or is difficult [2]. Therefore, the secondary pouring of the decorative line is generally required after the concrete pouring of the main structure is completed. In the process of secondary pouring, it is generally necessary to plant reinforcement at the reinforced concrete line and chisel the concrete surface, which will increase the difficulty of high-altitude operation and construction safety hazards in the construction process. In addition, considering that the size of the decorative line is generally small, it is difficult to process and support the formwork, the construction progress is slow, and the construction cost is high. In addition, due to the complexity of the whole construction process of secondary pouring, it is difficult to effectively ensure the construction quality of decorative lines after the completion of construction, especially the connection strength between decorative lines and the main structure, which leaves a hidden safety hazard for the use of subsequent building structures [3]. In order to

solve many problems existing in the secondary pouring method, this paper puts forward a construction method for the post installation of concrete decorative lines on the building facade, and defines the principle of this method by using the theoretical analysis method, the design method of this method by combining the mechanical analysis method, and the construction process of this method by combining the actual site construction. Finally, this method is applied to engineering practice, and combined with engineering practice, the cost saving and other advantages of the post installation method of building facade concrete decorative lines compared with the secondary pouring method are clarified.

2. Analysis on Deficiency of Secondary Pouring Method for Concrete Decorative Line

In the construction of the main shear wall structure, considering the difficulty of formwork erection, the decorative lines can not be poured with the main structure at one time and need to be poured twice. In the traditional secondary pouring construction process, firstly, the joint of the decorative line and the shear wall is roughened; Secondly, drill holes on the side of the wall to facilitate subsequent formwork fixation and rebar planting; Then, erect and reinforce the decorative line formwork; Finally, planting, reinforcement and concrete pouring shall be carried out. From the whole construction process, it can be seen that the secondary pouring method has the following shortcomings:

(1) Environmental pollution. Roughening during construction may cause dust pollution and risk of violating relevant laws and regulations; It will affect the health of construction workers.

(2) The construction operation is difficult and the safety risk is high. The secondary pouring construction process of decorative line involves high-altitude operation, and there are many construction processes, resulting in time-consuming construction, low production efficiency and high safety risks.

(3) Serious material waste and high construction cost. After each layer of decorative line concrete is poured, the remaining small amount of concrete will generally be treated as construction waste, resulting in waste of materials. In addition, considering the complex construction process of the secondary pouring method, the actual construction unit needs to invest more human and material resources in the construction of decorative lines to ensure that the needs of the on-site construction progress are met, which will also increase the construction cost.

(4) It is difficult to control the quality in the construction process, and the forming quality is poor. The construction process of decorative lines is relatively complex, and it is generally high-altitude operation. The control of construction quality generally requires the consciousness of the operation team. It is difficult to form effective supervision and control over the quality of the construction process, which directly leads to the poor forming quality of decorative lines after the completion of construction, resulting in the poor connection between decorative lines and the main structure, concrete formwork expansion, dislocation and other quality problems.

3. Analysis of Post Installation Principle of Concrete Decorative Line

In order to solve the problems of environmental pollution, difficult construction operation, high safety risk, serious material waste, high construction cost, difficult quality control in the construction process and poor forming quality in the secondary pouring method of concrete decorative lines, this paper puts forward the post installation method of concrete decorative lines based on the prefabricated construction concept. The core idea of this method is to prefabricate concrete decorative lines on site and then install them at high altitude. Specifically, firstly, the plastic sleeve with nut fastener is embedded at the reinforced concrete decorative line of the main structure beam or shear wall, and the plastic sleeve of the fastener is fixed on the main structure beam or shear wall formwork through screws. Secondly, the reinforced concrete decorative lines are prefabricated at the construction site according to the design drawings, and PVC sleeves are embedded in the prefabricated reinforced concrete lines. Finally, the prefabricated reinforced concrete decorative lines are connected with the plastic sleeves with nuts and fasteners embedded in the main structural beams or shear walls through hexagon bolts.

4. Design and Calculation Theory of Precast Concrete Decorative Line

The self weight of the decorative line is mainly transmitted to the main structure through the hexagon bolt, and the hexagon bolt mainly bears the shear force caused by the self weight of the decorative line. Considering that the post installation of concrete decorative lines mainly needs to determine the specification and spacing of connecting bolts between the decorative lines and the main structure, and the determination of the two needs to meet the shear capacity

requirements of connecting bolts under the self weight of the decorative lines, and the anti sliding requirements between the decorative lines and the main structure. Specifically, the shear capacity of bolts shall meet

$$N_v = \gamma_c A_c l_c \leq N_v^b = \frac{\pi d^2}{4} f_v^b \quad (1)$$

Anti sliding requirements

$$N_v = \rho_c A_c l_c \leq N_v^{rb} = 0.9 k n_f \mu P \quad (2)$$

Where, γ_c refers to the weight of decorative line concrete; A_c represents the cross-sectional area of the decorative line; l_c indicates the distance between adjacent connecting bolts; d indicates the diameter of the bolt; f_v^b represents the design value of bolt shear strength; k indicates pass coefficient, generally 1.0; n_f represents the number of force transmission friction surfaces, taking 1.0; μ represents the anti sliding coefficient of the friction surface, which can be taken as 0.8; P represents the design value of pretension of a high-strength bolt. By combining formula (1) and formula (2), appropriate bolt specifications and bolt spacing can be designed.

5. Construction Process Flow of Post Installation of Precast Concrete Decorative Line

As shown in Figure 1, the specific construction of precast concrete decorative lines includes three steps: installation of fastener plastic sleeve in the main structure, prefabrication of reinforced concrete decorative lines, and installation of reinforced concrete decorative lines.

5.1. Installation of Fastener Plastic Sleeve in Main Structure

1 Measurement and positioning

Measure and set out according to the construction drawings, and accurately locate the positioning line and control line of the plastic sleeve of fasteners.

2 Fixing fastener plastic sleeve

According to the positioning line of the plastic sleeve of the fastener, fix the plastic sleeve of the fastener on the inner side of the outer formwork of the structural beam or shear wall with a hand electric drill through screws, and recheck the position after fixing.

3 Concrete pouring

During the concrete pouring of the main structure, a special person shall be arranged to take care of it. During the pouring, it is strictly prohibited to dump the concrete directly on the casing. During the concrete vibration, the vibrator shall avoid this position.

4 After the structural concrete meets the formwork removal conditions, the beam or shear wall formwork shall be removed and the position of the plastic sleeve of the fastener shall be rechecked.

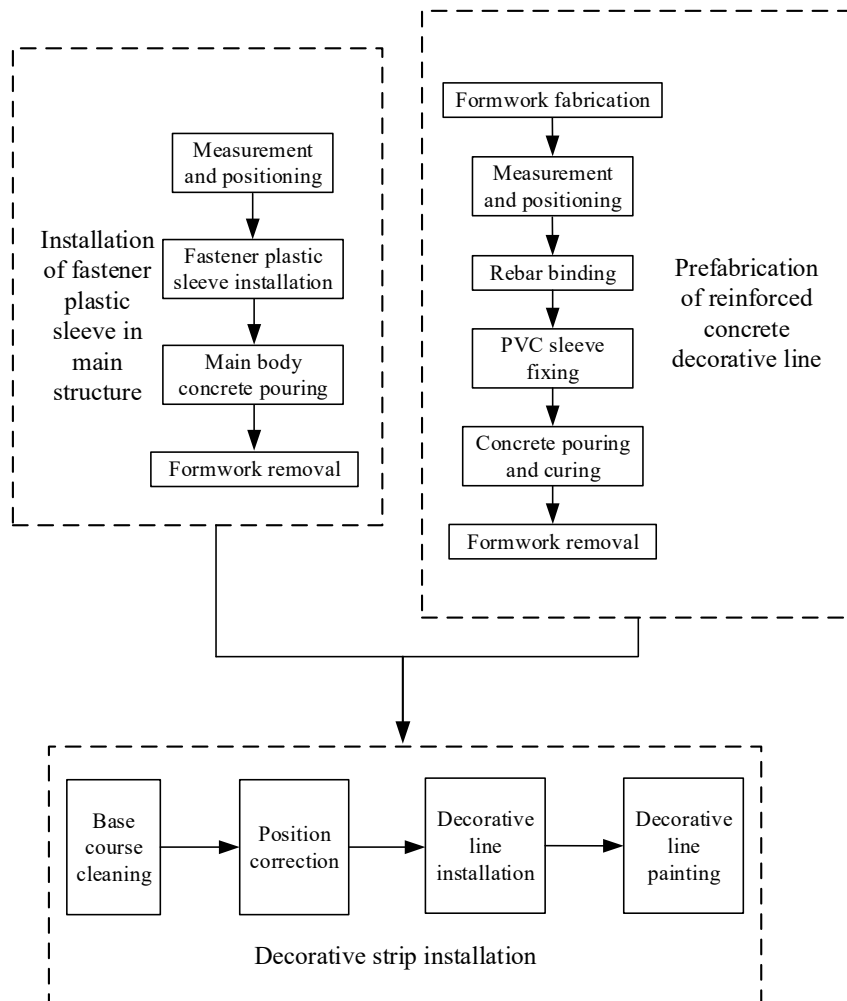

Figure 1. Construction process flow of post installation of precast concrete decorative line

5.2. Prefabrication of Reinforced Concrete Decorative Line

1 Formwork fabrication

According to the size of each single building and each layer of reinforced concrete decorative lines, make statistics and classification, and make formwork molds. The bottom formwork of the decorative line formwork is the splicing of waste formwork on site. The side formwork is a 10cm high timber square with standard size. The timber square and the bottom formwork are separable. One end of the side formwork is fixed and the other end is adjustable.

2 Measurement and positioning

Snap the center line of the embedded PVC sleeve on the bottom formwork of the prefabricated decorative line for bolt positioning.

3 Rebar binding

According to the design drawings, the corresponding reinforced concrete decorative bars shall be bound and fixed.

4 PVC sleeve fixing

Add a horizontal steel bar at the position of embedded PVC casing, fix the PVC casing through the horizontal steel bar, and the spacing of single line PVC casing is 50cm.

As shown in Figure 2, the concrete of the same grade of the original design (the same as the structural floor) shall be used for pouring after the experience of the precast reinforced concrete bar binding and PVC sleeve fixation is received. During the concrete pouring process, attention shall be paid

to whether the casing is in a displaced state, and the concrete shall be vibrated at the same time. The concrete shall be cured for 7 days after pouring.



Figure 2. Precast concrete decorative line

5.3. Decorative Strip Installation

1. Base course cleaning: after the structural shear wall / beam formwork is removed, the base course of the decorative line shall be cleaned to check whether there is reserved blockage, and the uneven surface shall be treated simply

2 Position correction

Carry out elevation correction for the position of the reserved installation hole of the decorative line, and handle it in time in case of local deviation.

3 Install the decorative strip

The prefabricated lines are transported to the installation floor by the construction elevator for installation, as shown in Figure 3. The installation position of the decorative lines is determined according to the reserved installation holes of the structure, and then corrected according to the elevation horizontal line; After the positioning of the precast reinforced concrete decorative line is completed, the bolts shall be simply fixed through the PVC pipe in the precast decorative line and the structural embedded nuts. When the whole precast concrete decorative line is preliminarily fixed, the electric wrench shall be used to tighten each bolt of the line until it is completely fastened.

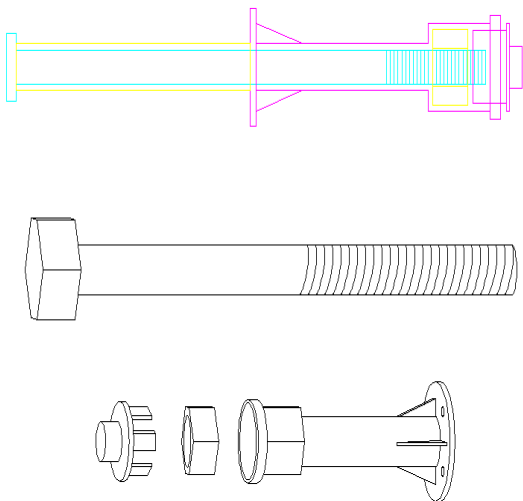

(a). Schematic diagram of bolts and accessories

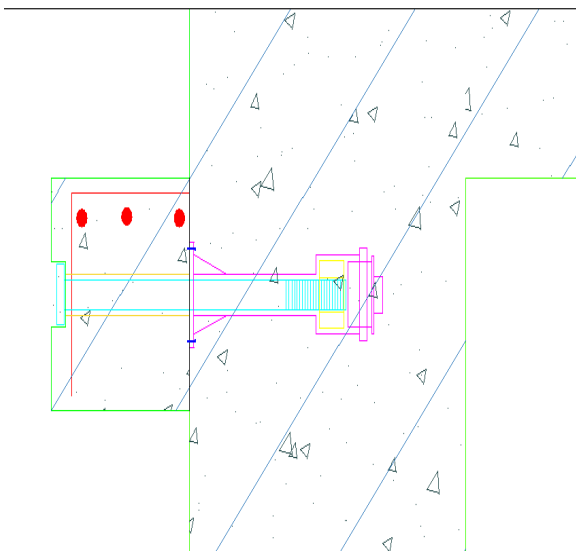

(b). Sectional drawing of connection between bolt and prefabricated decorative strip

Figure 3. Decorative strip installation schematic diagram

4 Decoration line painting

After entering the exterior wall painting stage, the lines shall be painted according to the construction process and the requirements of the design drawings; See Figure 4 for the concrete decorative line of the building facade after the final construction.

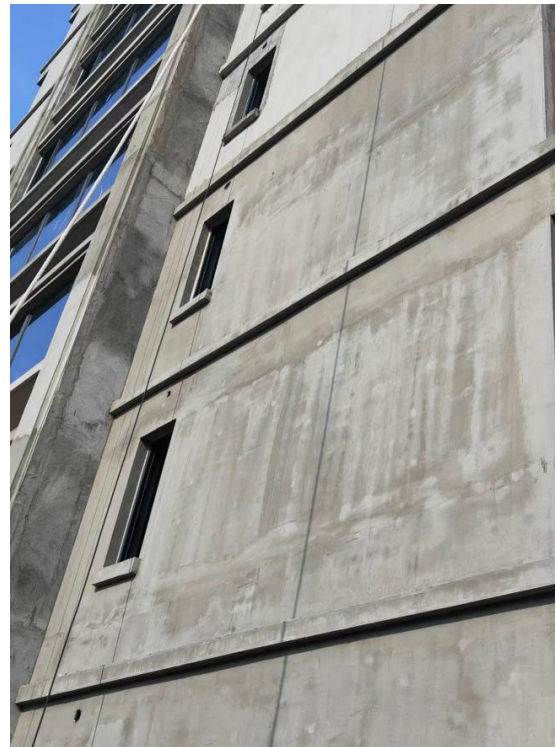

Figure 4. Effect drawing of concrete decorative line installation completion

6. Engineering application

A high-rise residential project with a total construction area of 136855.15 square meters and two floors of basement; There are 12 single buildings with different heights of 16~18 floors and two-story shops on the ground. Decorative lines are designed on the facade of the single buildings and shops. Considering that the shear wall and beam parts of each facade on each floor are designed with reinforced concrete decorative lines, which cannot be poured at one time during the construction process, and the traditional secondary pouring construction method has the disadvantages of high cost, long construction period, weak rebar planting, etc., the project adopts the post installation construction method of building facade concrete decorative lines.

After considering the costs of rebar planting, roughening, concrete pouring and artificial machinery, it is estimated that the total cost of decorative line construction by using the traditional secondary pouring method is about 1619100 yuan, while the total cost of the post installation method proposed in this paper is about 1247000 yuan, saving about 30% in total.

In addition to saving the project cost, the post installation construction method has the following advantages in combination with the site construction

(1) Environmental protection. During the construction process, the embedding, bolt connection and other operations are mainly carried out, which does not involve concrete roughening treatment, will not produce dust pollution, and will not affect the health of construction workers.

(2) The construction operation is small and the safety risk is small. The decorative lines are prefabricated at the construction site and bolted after prefabrication. The overhead operation time is short, the production efficiency is high and the safety risk is small.

(3) Material saving and low construction cost. The decorative lines can be prefabricated on site in batches without waste of concrete. The formwork used in the

prefabrication process mostly adopts the waste formwork removed from the main structure. Therefore, the purpose of material saving and low construction cost can be realized. In addition, the installation and construction of prefabricated decorative lines on site is fast and efficient, which can also effectively reduce the project cost.

(4) The construction process is easy to control, and the molding quality of decorative lines is guaranteed. The construction process of the decorative line post construction method is simple. The actual construction site only needs to ensure the prefabrication quality of the decorative line prefabricated parts and the connection quality of the connecting bolts. The site management personnel can effectively supervise and control the quality of the construction process, and can effectively ensure the molding quality of the decorative lines, so as to meet the requirements of the construction unit and the design unit for the facade modeling, and improve the overall quality of the project.

7. Conclusion

In order to solve the problems of environmental pollution, difficult construction operation, high safety risk, serious material waste, high construction cost, difficult quality control in the construction process and poor forming quality in the secondary pouring method of concrete decorative lines, this paper puts forward the post installation method of concrete decorative lines based on the prefabricated construction concept. The principle of the method is clarified by using the theoretical analysis method, the design method of the method is clarified by combining the mechanical analysis method, and the construction process of the method is clarified by combining the field construction practice. Finally, the method is applied to the engineering practice. The main conclusions are as follows:

(1) The post installation method of concrete decorative lines essentially adopts the prefabricated principle. It can effectively solve the problems existing in the secondary pouring method, such as environmental pollution, difficult

construction operation, high safety risk, serious material waste, high construction cost, difficult quality control in the construction process, poor molding quality and so on.

(2) The shear resistance of the connecting bolts between the decorative line and the main structure and the anti sliding requirements between the decorative line and the main structure shall be considered during the design of the decorative line.

(3) The post installation method of precast concrete decorative lines includes three steps: installation of fasteners and plastic sleeves in the main structure, prefabrication of reinforced concrete decorative lines, and installation of reinforced concrete decorative lines.

(4) Compared with the traditional secondary pouring method, the post installation method can save about 30% of the cost, and the post installation method is easy to control the quality of the construction process, and the molding quality of the decorative line is high.

Acknowledgment

The authors are grateful to funding received from the Project of China Construction 4th Engineering Bureau 6th Corp.Limited under grant number KT-2021-13.

References

- [1] Q. Qin, D. Chen, & H. F. Wang, "The application of prefabricated concrete decorative lines in residential projects," *Building Technology Development*, vol. 48, pp. 2–10, Feb. 2021(In Chinese)
- [2] S.L. Ding, J.H. Xia, Z. Yan, H.P. Lu, & L.Y. Zhu, "Construction technology of concrete decorative line," *Jiangsu Building Materials*, vol. A01, pp. 10–15, Mar. 2019 (In Chinese)
- [3] L. Luo, T.Q. Huang, Q. Yuan, et al, "One time forming construction technology of aluminum alloy formwork in full concrete exterior wall line," *Construction Engineering Technology and Design*, vol. 24, pp. 275–280, Dec. 2020(In Chinese)