



Energy Efficiency as a tool to improve buildings behavior In Egypt. A frame work to achive low energy buildings locally.

Heba Mahrous Ali Abd El Aal¹

¹Lecture In Architecture Department at Modern Academy for Engineering and technology In Maadi

Abstract

Sustainable development goals for 2030 depending on how to create a better life for people including all parameters which affect human to avoid the negative impacts of climate change which can destroy life on our planet.

Saving energy is one of the main global problems, and buildings are one of the influences on energy consumption. It is a must to solve this problem by identifying the causes which including the building features, operation process and the impact of its occupants. On the other hand, clarify permanent solutions according to modern concepts and techniques which can help to solve it locally.

The study attempts to clarify human, nature environment and built environment impacts, in indicating how buildings play an active role in achieving various stages of energy consumption or production to address the energy efficiency importance.

This paper discusses this issues and gives recommendations and proposals on how to solve problems

ensure the achievement of low energy buildings in Egypt depending on the parameters which respect and depend on our local environment in Egypt.

© 2020 The Authors. Published by IEREK press. This is an open access article under the CC BY license (<https://creativecommons.org/licenses/by/4.0/>).

Keywords

Energy consumption; Low Energy Building; Energy efficiency; energy use; Human Impacts; local culture.

1. Introduction

Over the last decades, there has been an increasing awareness of the dispiriting connection between traditional economic development and the over exploitation of the world's natural resources. Pollutants and harmful residues from land stripping and the production of building materials increasingly stress the environment. (Fakosh & Ahmed, 2012).

Energy is not a local problem, but it is an international issue as it affects all life themes. how to use and save it need a new solutions according to the current activities, technologies and human needs, The Middle East faces considerable energy and environmental challenges which result from its huge energy demands. (Abdul Salam, 2010)

According to the continuously growing population creates a huge demand for energy, high energy consumption means high carbon dioxide levels also amongst the highest in CO₂ emissions. (Asif, 2015)

Energy consumed for cooling and heating in buildings is becoming an increasingly serious source of global warming. Buildings are responsible for 48% of energy consumption and 45% of CO₂ emissions within the region, see Figure

1, it shows sectors of energy consumption and illustrates that buildings account for the highest amount of energy consumption (UNEP, 2007).

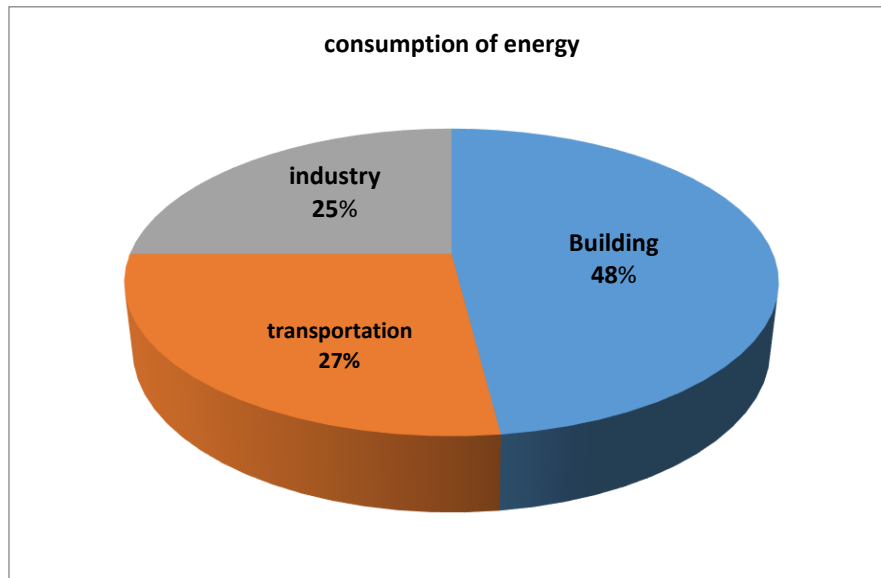

Figure 1. consumption of energy-(UNEP, 2007).

Egypt, as a developing country, is in serious need for saving resources and providing housing for an increasing population, the current way of building rarely has not any green incentives or conforms to global energy saving models.

Moreover, the recently launched ‘Sustainable Development Strategy of Egypt’s vision 2030’ by the Egyptian government as part of the Economic conference held in Sharm El Sheikh, aims at the economic development, human capital and the competitiveness of the Egyptian market (SIS 2015). Among the objectives of the strategy is to (1) improve the productive capacity of the energy sector; (2) reduce the waste disposal and the associated costs with it; (3) improve the wellbeing of the Egyptian citizens; and (4) reduce the environmental footprints and greenhouse gases from the various sectors (MOP 2015). Thus, sustainability in the construction and buildings sectors through a green building rating system will have a vital role in the successful achievement of this strategy. (Hebaalla,2016)⌋

This paper focus on presenting a solutions for some questions as an analytical study to clear the concept of efficiency from definition to applications to improve the local vision for achieving low energy buildings.

2. What is the relation between building and energy use ?

Buildings have an enormous and continuously increasing impact on the environment, using about 40% of natural resources extracted in industrialized countries, consuming nearly 70% of electricity and 12% of potable water, and producing between 45% and 65% of the waste disposed in landfills .Moreover, they are responsible for a large amount of harmful emissions, accounting for 30% of greenhouse gases, due to their operation, and an additional percent of 18% caused indirectly by material exploitation and transportation.

3. Egypt & energy consumption

Among the many challenges that Egypt is facing, is to fulfill the rising oil demand with its declining production. An annual average increase of 3% was recorded for the total oil consumption over the past 10 years, averaging about 775,000 bbl. /d in 2014 (EIA 2015). Figure 1.2 shows that Egypt's oil consumption has surpassed its production since 2010. Additionally, Egypt’s 2013 total energy production was about 691,000 barrels per day (EIA 2015). Furthermore, Egypt suffers regular electricity power cut because of rising demand, natural gas supply shortages, old infrastructure, and insufficient generation and transmission capacity.

Almost 152 billion kilowatt-hours (KWh) of electricity was produced in 2012, of which about 70% was powered by natural gas, 20% by oil, and less than 10% by renewables, mostly hydropower generation (EIA 2015).

Furthermore, the electricity consumption in Egypt has been increasing where the peak load demand has amplified at an average annual rate of 8% over the last decade, reaching about 30 GW in 2013/2014. The rapid growth of energy use has created anxieties over problems of energy supply, energy sustainability and exhaustion of energy resources; this increasing consumption of energy sources has led to serious environmental problems such as global warming and air pollution (Nabih, et al. 2011). This deficit and insufficiency in the production of resources is due to the uncontrolled system caused by the scattered and unorganized approaches followed by the building users.

Due to the depleting fossil fuel resources worldwide, one of the solutions to overcome this problem is to adapt to renewable energies in Egypt particularly that 60 percent of its area has a solar energy intensity that exceeds 6.4 kWh/m²/day, see Figure 2. Renewable energy use in the Egyptian market is very limited when compared with other regions around the world. Thus, the call for renewable energy is of ultimate importance in the meantime. Furthermore, the advances in on-site renewable energy technology have brought the concept of net zero energy buildings.

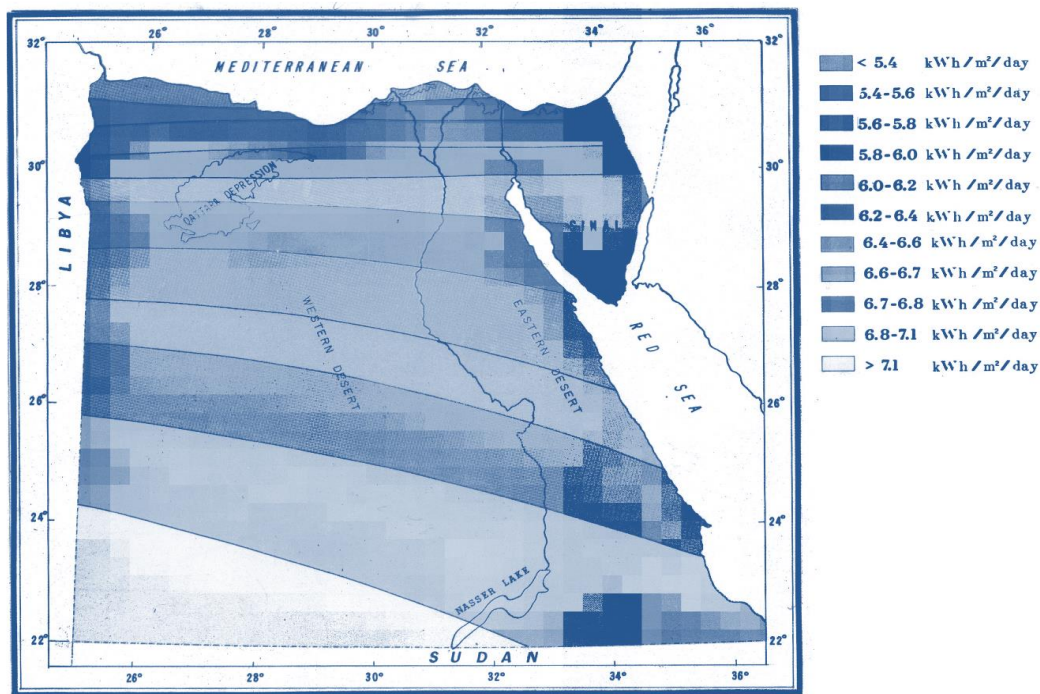

Figure 2. Egypt annual average of direct solar radiation (ECAA 2017)

4. Egyptian Community impact and Energy Consumption:

The Egyptian community depends on mechanical equipment almost entirely when dealing with climatic issues. Air conditioners have become one of the basics of home and office appliances, see figure.3. to the extent that new buildings now are delivered to end users with cantilevers hung on certain walls to bear the compressor units of air conditioners, and with openings ready for the window-type units (Robroad .com, 2012) Many houses and most offices are designed to use artificial light even during day, in spite of the huge solar radiation Egypt receives every day)

The current way of building in Egypt was not design environmentally, although Egypt is a developing country in serious need for saving resources. It does not provide users with the required comfortable and healthy environment they need (Karim, 2011).

Although the Egyptian government has developed both energy efficiency standards and energy labels for the most popular appliance such as "ECP 304/2-2004 a code for refrigerating and air conditioning" ,which goals to provide the minimum level of comfort and public health as well as to save energy ,the application s are not satisfied (Usama, 2011)

Furthermore, the raw materials we are still using in Egypt are the products of very polluting and energy consuming industries like cement, masonry and aluminum. This is mainly because most of the practitioners in the construction field do not adopt the principles of green architecture in their work.



Figure 3. Air conditioner technicians risking lives to install units. (Source: Online Mail Newspaper, 24 Octobe,2008)

5. Using energy codes:

There are a standard codes deals with energy such as ANSI/ASHRAE/USGBC/IES24 Standard 189.1-2011, widely known as ASHRAE Standard 189.1 was released in 2011 by a committee with representatives from ASHRAE, AIA, USGBC, ANSI and IES. ASHRAE and US. Green Building Council (2011), The main points that are discussed in the standards are; CP 306-2005 The Egyptian code for energy efficiency improvement in buildings Part 1.

This code is applicable to residential buildings. It covers requirements related to energy efficiency in buildings through passive and active strategies (NUCA. 2016.)

6. How to solve this problem locally?

This step is important in order to produce a building that properly solves the environmental case of its context and provides comfort for customers to achieve low energy buildings (Saber, 2010), by following these points:

1. Use of resources wisely.
2. Decrease energy use.
3. Provide healthier work and living environments.
4. Achieve a balanced distribution of population.

Taking those regulations into consideration during the design phase will help produce designs that can cope with the hot-arid environment, so we can decrease the impact of heating which need much energy which is electricity to get human comfort.

As Egypt is a country with a hot-arid weather during most of the year, with sand deserts making 95% of its land area. This fact indicates special architectural treatment when erecting buildings, using certain green techniques. On two phases; design and technical tools which deal with buildings operations (UNCCD,2005).

6.1. Design phase:

1. Orientation.
2. Looking-in plan.
3. Inner courtyards.
4. Wind-catchers.
5. Least glass surfaces
6. Increasing green areas
7. Creating water surfaces (Ficarelli, L. ,2009).

6.2. Using Technical tools :

New technologies can improve the consumption of energy to achieve efficiency . it can help architects to provide users with solutions that are comfortable, affordable and environmentally-friendly. See figure4, They also help the user to lead a healthy and more economical way of life. Adopting these technologies can get people closer to green concepts and understand the importance of using them in architecture (Karim,2012). Examples for the green technologies that can be used in such as;

6.2.1. Solar tubes:

They are lighting systems consisting mainly of tubes with reflective surface that are capable of transporting natural sunlight into spaces which are not reached by direct sunlight.

6.2.2. Solar chimneys:

They are architectural elements made from transparent materials, usually glass, allowing sunlight to heat the air inside it. The hot air evolves and is naturally replaced by cool air coming from the opposite direction, causing an artificial air current that helps cooling the building.

6.2.3. Natural coolers:

There are different kinds of cooling devices that need no electric current or sophisticated equipment.

6.2.4. Sensor controls:

Sensor controls can help save a lot of resources when used in residential or commercial building. Sensors can be used to turn lights on and off automatically when users enter a certain space. They are also used to turn water taps on and off when users place their hands underneath the tap.

6.2.5. Solar heaters:

The technologies of using solar power for heating building indoor atmospheres using water or oil as media for heat transmission has been widely used since decades. The most commonly used solar heater is that used with water as a medium.

6.2.6. Photovoltaic panels:

They are panels of photo-sensitive materials that have the ability to generate electric power from light energy received from the sun.

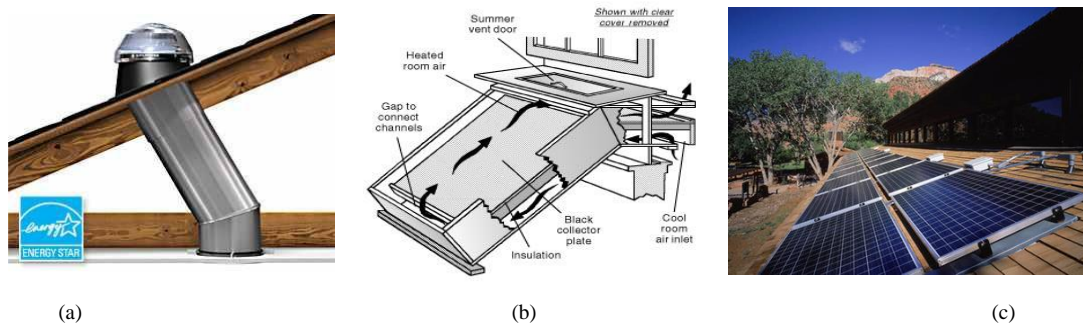

Figure4: technical tools

(a) :Solar Tube™ daylight system. (Source:www.solatube.com)

(b): A Solar Box water heater.(Source:www.homeconstructionimprovement.com)

(c): p.v panels . .(Source:www.homeconstructionimprovement.com)

7. How to achieve low energy buildings in Egypt?

It can be achieved if architect respect some elements to can decrease the building use which are:

The architecture design of the building, envelop, construction, Islamic elements, technics, culture and climate.

7.1. architecture design of the building:

7.1.1. Form:

1. The structural design of the building bloc should minimize external surface and roof areas exposed to the sun's rays. The ideal form is a primary one (square, circle). Loosening the blocstructure by adding a courtyard augments the flexibility of an environmentally appropriate design.
2. Natural light should penetrate 4.5 m into the building's interior; the deeper the light penetrates, the weaker the lighting becomes. Natural light that penetrates up to 9 m inside the building provides good lighting; beyond this distance, building interiors require artificial lighting.
3. The greater the height of a building, the more effective is ventilation and the wind's effect in reducing thermal radiation levels.
4. Sound insulation through judicious use of quiet spaces (they should be close together and separated from noisy spaces) (Waleed,2014)

7.1.2. Orientation:

1. Orientation affects a space's thermal comfort level, ventilation and natural lighting. A northward orientation is the most suitable; it is not exposed to direct sunshine and allows for a steady level of natural light. Ensuring that the widest side of the building faces north will attract sought-after wind, and the largest openings should therefore be located on this side. The East and West-facing sides of buildings are not conducive to good natural lighting. Southward-facing sections are desirable in the winter season, and regulating incoming sunshine is an easy matter throughout the rest of the year.

7.2. Building envelope design:

7.2.1. Roofs:

1. Sloping roofs, heat insulation materials (lightweight brick) and heat deflective light colored materials should be used.
2. Creating insulating air vacuums by constructing double roofs (two tile layers)
3. Elevated ceilings allow for increased ventilation. Ceilings should be of different heights and upper openings (in ceilings) should be installed.

7.2.2. Walls:

1. Construction materials such as burnt brick should be used to reduce heat conduction from outdoors to indoors
2. Constructing double walls, using light colored, heat deflective materials
3. Shading walls and building ledges on the walls of upper floors
4. At both the vertical and horizontal levels, walls should be tilted to allow for the angle of the sun's rays.
5. Using coarse surfaces to deflect the sun's rays
6. Using openwork wall structures, upper openings and skylights

7.2.3. Openings

1. Narrow openings in hot zones; they should be shaded and equipped with sunscreens
2. In Egypt, openings facing north are the most suitable for lighting and ventilation.
3. The greater the width and height of the openings, the more natural light penetrates into and spreads in building interiors.

4. Openings should be installed on several walls and upper openings should be used as well.
5. At least one air inlet, larger than the air outlet, should be provided

7.3. Construction Materials in Design:

1. using Natural and renewable construction materials that are suitable to the building site and the surrounding environment should be used.
2. Light color, low thermal conductivity materials with coarse surfaces to deflect radiation and heat should be used.
3. Durable, energy-efficient construction materials should be used.

7.4. Reusing Islamic architecture elements:

Construction materials and environmental solutions make use of natural resources and energy sources (sun, wind, and construction materials) to provide an interior environment that is both comfortable and in harmony with social values and culture.

7.5. Strategies and Technology techniques:

Optimizing the use of engineered materials which provide high strength and durability with the least amount of material and benefit out of proven engineering principles such as structural systems (concrete/steel, other...), insulated concrete forms, engineered trusses, composite materials and structural insulated panels (stress skin panels), and frost protected shallow foundations.

Identify ways to reduce the amount of materials used and reduce the amount of waste generated through the implementation of a construction waste reduction plan. (sheriff ,2014)

7.6. Strategic Energy Technology Plan

The strategic energy technology plan is the key decision-making support tool for many countries' energy policies. It encourages the development and use of low-carbon technologies through the wide dissemination of education and information technology. (Angelidou, M. 2014.) It is characterized by specifying targets that will be achieved within a set period of time or by a certain deadline.

7.7. Respecting the local community culture

Human needs, activities, faiths which can be called its culture is one of main elements which control energy use. As technology can control human behavior to decrease its negative impacts to achieve energy efficiency

7.8. Climate needs

Hot arid climate must be respected as providing the successful models in design of form, materials, orientation which must designed to decrease heating inside building,

8. A checklist for achieving low energy buildings in Egypt

The criteria are presented to can analysis the building statues to can improve it by clearing the main factors:

1. building operations.
2. Form of building
3. external envelope
4. Construction and finishing materials.
5. Building appliances.

Table 1. The checklist can be used by architects who can analysis and improve

Building Description:								
Name:.....								
Type of building:.....								
Area:.....								
Climate:.....								
factors	comments	rating of factors						
		0-40%	50%	60-80%	85≤			
Building operations (energy use)	Heating (artificial-natural)							
	cooling(artificial-natural)							
	lighting(artificial-natural)							
	Type of Energy used							
Form building of	Design of form							
	Shading elements							
	courtyard							
	Plan parameters							
	orientation							
External envelop	ceiling	type						
		shading						
		insulation						
	wall	orientation						
		insulation						
	opening	Type of glass						
		orientation						
		area						
	construction	Materials of envelope (ceiling-wall)	U. value R. value					
Structure system		Height span						
application	For heating	equipment						
	For lighting	equipment						
	For cooling	equipment						

9. Conclusion:

- We need to be moving ,as a country, toward sustainable,efficient buildings, but let the market dicate our direction.market demand encourages innoation.if solar power systems are too expensive today ,donot force them on the public,but ask companies to build it in a differet way to reduce the cost.
- Making use of traditional architectural solutions that are suitable to local environmental conditions to provide thermal comfort, natural lighting and ventilation and to successfully design a green home.
- The importance of integrating and consolidating local environmental principles intoEgyptian construction law and systems.
- The importance of assessing the environmental impact of construction projects andpromoting the adoption of energy efficiency principles .
- With Egypt preceding to sustainable development through its latest ‘Strategic Vision 2030’ announced in March 2015, methods and tools are becoming crucial to achieving the vision’s goals. There are hundreds of green building tools including one dimensional, two dimensional and total sustainability assessment tools.

For achieving the concept of Energy efficiency in Egypt we need to clarify the building into three categories :

First: how building work efficiency :

- Mandatory provision of space and equipment for the future installation of renewable energy systems such as solar and wind energy collection systems.
- Mandatory provision of measurement devices of remote communication capabilities for all energy sources in the building such as electricity and natural gas, in order to transmit consumption data to a data acquisition system.
- Building envelope design and insulation depend on climatic analysis of the project location.
- Control human behaviours in building operations to control energy use.

Second :how to design Building Envelope:

- Presenting the standard classification of the bioclimatic zones of Egypt and their respective building envelope design recommendations.
- Enforcement of bioclimatic calculations and analyses as part of construction documents necessary for licensing.
- Limitation to the use of materials and building techniques which are incompatible with the results of the bioclimatic analysis for the specific climatic zone.

Third : importance of following energy codes for Indoor environmental quality and comfort:

- Buildings shall be designed in compliance with ASHRAE 55 – 04 (according to thermal comfort specifications of the climatic zone), except spaces with special requirements for processes, activities, or contents that require a thermal environment outside of that which humans find thermally acceptable, such as food storage, natatoriums, shower rooms, saunas, and drying rooms.

References:

- Abdul Salam Darwish, (2011),Sustainable Green Smart Buildings: Future Energy Survivor, ISESCO JOURNAL of Science and Technology Vol. 12 No 21.
- ASHRAE and US. Green Building Council, (2011) ANSI/ASHRAE/USGBC/IES Standard 189.1-2011, ASHRAE, Atlanta, GA, pp.19-22,.
- Asif, M.. (2015) Growth and sustainability trends in the buildings sector in the GCC region with particular reference to the KSA and UAE, Renewable and Sustainable Energy Reviews.
- Ayyad, Karim. (2011). Marketing Green Architecture in Egypt: Integration of Green Architecture into the Mainstream Construction Market in Egypt. 10.13140/RG.2.1.4035.6243.
- EEAA..(2008) Renewable Energy Strategy for Scientific Research. Cairo: Energy Research Center-Faculty of Engineering Cairo University,.

- EIA, U.S. Energy Information Administration.(2015). "Egypt - International - Analysis - U.S. Energy Information Administration (EIA)" 2015: 1–13.
- Fakosh, U. and Ahmed, R. (2012). The employment of technical development to the direction of high-technology buildings within the framework of sustainable design. *Damascus University Journal of Science and Engineering*, 226-246.
- Ficarelli, L. (2009), The Domestic Architecture in Egypt between Past and Present: The Passive HEBAALLA MOSTAFA KARMANY, EVALUATION OF GREEN BUILDING RATING SYSTEMS FOR EGYPT, A Thesis Submitted to Center for Sustainable Development in partial fulfillment of the requirements for the degree of Master of Science in Sustainable Development ,the American university in cairo,2016.
- Home-SIS*. Sis.gov.eg. Retrieved from <http://www.sis.gov.eg>.
- Housing and Building National Research Center. NUCA.
- Karim M Ayyad.,(2014) Marketing Green Architecture in Egypt: Integration of Green Architecture into *Journal of Asian Scientific Research*, , 4(6): 260-269.
- Karim M ayyad,mostaafa gaber,(2012) Greening Building Codes in Egypt, *Sustainable Futures: Architecture and Urbanism in the Global South* Kampala, Uganda.
- MOP.(2015). Ministry of Planning. *Egypt Sustainable Development Strategy 2030*.,
- Nabih, Ahmed, Mina Michel Samaan, Osama M.A. Farag, and Alaa S. El Aishy.. (2011) "USING SIMULATION TOOLS FOR ENHANCING RESIDENTIAL BUILDINGS." *Proceedings of Building Simulation 2011: 12th Conference of International Building Performance Simulation Association*, Sydney, 14-16 .
- Saberi, O. et al.(2010) ,*Thermal Comfort in Architecture*, Shahid Beheshti University Press, Iran,.
- SIS. (2015). State Information Service. *Egypt Launches Sustainable Development Strategy*.
- Sweepnet. (2014). The Regional Solid Waste Exchange of Information and Expertise network in Mashreq and Maghreb countries. "Country Report on the Solid Waste Management in Egypt" the Mainstream Construction Market in Egypt, master thesis, faculty of engineering ,Cairo university.
- U.S. Energy Information Administration (EIA). Retrieved from <http://www.eia.gov>
- UNCCD (2005), *Egypt National Plan to Combat Desertification*, Arab Republic of Egypt Ministry.
- Usama el fiky , (2011)towards a green building law un Egypt :opportunities and challenges, *Science Direct-ELSEVIER-energy procedia*6,.
- Waleed Hussein, (2014),AN APPLICABLE APPROACH TO GREEN ARCHITECTURE IN EGYPT PROPOSED MEASUREMENT MATRIX MODEL TO ASSESS THE USE OF HISTORICISLAMIC ARCHITECTURAL ELEMENTS AND REPERTOIRE IN THE APPLICATION OF GREEN ARCHITECTURE PRINCIPLES AND CONCEPTS, *Global Journal of Arts Humanities and Social Sciences*, Vol.2, No.10,pp.6-29,