

# A Thorough Examination of Harmonic Mitigation Techniques Through a Comparative Study of the UVT and PWM Methods within Power Systems

Miss Nisha Babulal Lodha<sup>1</sup>, Mr.Hitendra Babusinh Vaghela <sup>2</sup>, Mrs Grishma Pratik Pipaliya<sup>3</sup>,  
Miss. Rina Shailesh Parikh<sup>4</sup>

<sup>1,2,3</sup>Electrical Engineering Department, Assistant Professor, Vishwakarma Government Engineering College,  
Chandkheda, Ahmedabad, India

<sup>4</sup>Electronics & Communication Engineering Department, Assistant Professor, Vishwakarma Government Engineering  
College, Chandkheda, Ahmedabad, India

---

## Article History:

**Received:** 01-08-2024

**Revised:** 07-09-2024

**Accepted:** 18-09-2024

## Abstract:

**Introduction:** To mitigate the harmonic disturbances caused by non-linear loads, the selection of active power filters has emerged as a means to enhance filter efficiency and address numerous issues associated with traditional passive filters. A critical aspect of effectively implementing an active filter is the adoption of a robust method for generating current or voltage references. Various implementations, grounded in different theoretical frameworks (whether in the time or frequency domain), continuously evaluate their performance to provide increasingly effective solutions.

**Objectives:** This paper presents a comparative review of two distinct methods. Specifically, it examines the shunt active power filter, where the control strategies are based on the Unit Vector Template (UVT) and compares it with the Pulse Width Modulation (PWM) method.

**Methods:** SPWM modulation control method employs a single pulse for every half cycle, and the duration of this pulse is modified to control the output voltage of the inverter. Gating signals are generated by comparing a rectangular reference signal of amplitude  $E_r$  with a triangular carrier wave of amplitude.

The basic system block diagram, showing the use of the UVT (Unit Vector Template) approach. The SAF acts as a component linked in series, successfully neutralizing the harmonic and reactive currents generated by a nonlinear load. As a result, the overall current taken from the primary AC source displays a sinusoidal pattern. In an ideal scenario, the Active Filter (AF) should generate only the required harmonic current to compensate for the nonlinear loads in the circuit.

**Results**This report explores a method for reducing harmonics using the Shunt Active Filter (Shunt AF) to improve the quality of electric power at the distribution stage. The Shunt AF efficiently tackles the power quality issues linked to current from loads, such as reactive current, imbalance, harmonics, and neutral current.

**Conclusions:** Out of the two methods examined, the Unbalanced Voltage Technique (UVT) exhibits better results. When compared to other methods, the UVT method offers several advantages such as smaller switching losses, less memory utilization, reduced computing requirements, and much higher speed. .

**Keywords:** Power Quality (PQ), Unit Vector, Pulse with modulation, Mitigation of Harmonic

---

## 1. Introduction

In everyday life, numerous sources produce harmonic currents. The nonlinearity of power electronic devices, along with elevated switching frequencies, primarily contributes to the generation of these harmonic currents. Such currents can adversely affect various power system components, control systems, circuit protection mechanisms, and other loads sensitive to harmonics. The presence of harmonics can lead to issues such as tripping of power supplies, overheating of building wiring, and potential failure of entire equipment systems. In the past, passive filters were employed to mitigate harmonics; however, these filters have certain limitations, which are outlined below. [3]:

The characteristics of a filter are significantly influenced by the source impedance.

At certain frequencies, the shunt resonance occurring between the source and the passive filter enhances the amplification of harmonic currents on the source side.

Additionally, a passive filter may enter into series resonance with the source, resulting in voltage distortion that generates unwanted harmonic currents flowing into the passive filter.

Numerous methods exist to diminish the impact of harmonics. Active power filters serve to alleviate issues related to harmonics [1, 2]. Consequently, the utilization and principles of active power filters have gained significant popularity and have drawn considerable interest [4, 5]. This technique for harmonic mitigation involves generating a reference current from the distorted waveform.

## 2. Shunt Active Filter

The Shunt Active Power Filter (SAPF) is a device that operates in parallel with the electrical system to mitigate reactive and harmonic currents produced by nonlinear loads. As a result, the overall current drawn from the alternating current (AC) mains exhibits a sinusoidal waveform. Ideally, the Active Power Filter (APF) is designed to generate just enough harmonic current to offset the effects of nonlinear loads present in the circuit. As illustrated in Fig. 1, the APF employs a current-controlled voltage source inverter to produce the necessary compensating current, which is then injected into the utility power source line. This process effectively cancels out the harmonic components generated by the nonlinear load, thereby maintaining the sinusoidal nature of the utility line current.

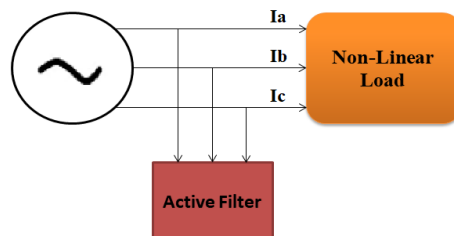

Fig.1 Basic diagram of Shunt Active Power Filter System

1. The Shunt Active Power Filter (SAPF) mitigates current harmonics by generating a compensating current that is equal in magnitude but opposite in phase. In this context, the SAPF functions as a current source, injecting harmonic components produced by the load, with a phase shift of  $180^\circ$ .

## 2.2 Shunt Active Power Filter

The primary objective of connecting active power filters by various consumers is to reduce current harmonics generated by non-linear loads. Furthermore, the connection of active power filters aims to address issues related to voltage and current imbalances, as well as harmonics imbalances within power distribution systems.

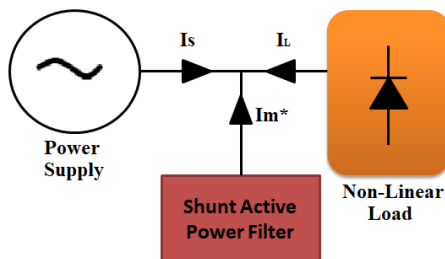

Fig. 2 Topology of Shunt Power Filter

Within the electrical power supply system, the active power filter will extract and introduce the compensating current illustrated in Figure 2,  $I_{m^*}$ , to the line in accordance with the fluctuations in the load. The current source is representative of both the load and the filtering current, as defined by the subsequent equation[6]:

$$I_{m^*} + I_L = I_S \tag{1}$$

The control strategy of an active filter is fundamentally essential to its operation and is implemented through three distinct steps [7]:

Step 1: The initial phase involves the detection of fundamental voltage and current signals through the utilization of potential transformers (PTs), current transformers (CTs), and Hall-effect sensors.

Step 2: The subsequent phase entails the generation of compensatory instruction signals, expressed in terms of current or voltage levels, which are formulated based on the control strategies and configurations of the active filter.

Step 3: In the concluding step, the gating signals for the solid-state devices within the active filter are generated through the application of hysteresis and pulse-width modulation control techniques.

## 3. Harmonic Identification Technique

TABLE 1: An overview of the predominant methods for harmonic detection utilized in Active Power Filters.

Frequency-domain	<ul style="list-style-type: none"> <li>• Discrete Fourier Transform (DFT)</li> <li>• Fast Fourier Transform (FFT)</li> <li>• Recursive Discrete Fourier Transform (RDFT)</li> </ul>
Time-domain	<ul style="list-style-type: none"> <li>• Immediate real and reactive power analysis using "pq-theory"</li> <li>• Unit Vector Template methodology (UVT)</li> <li>• Pulse Width Modulation (PWM) techniques</li> </ul>

### 3.1 Pulse With Modulation (PWM)

The output voltage of an inverter can be regulated through an internal control mechanism. One of the most effective techniques for achieving this is pulse width modulation control, which is implemented within the inverter. In this approach, a constant DC input voltage is supplied to the inverter, and a modulated AC output voltage is produced by varying the duration of the on and off cycles of the inverter's components. This technique is widely recognized as the predominant method for controlling output voltage and is referred to as pulse width modulation control [8].

There are various forms of Pulse Width Modulation (PWM) [9]:

- a. Single Pulse Width Modulation (SPWM)
- b. Multiple Pulse Width Modulation (MPWM)
- c. Sinusoidal Pulse Width Modulation (SPWM)

#### a. Single Pulse Width Modulation (SPWM)

This modulation control technique utilizes a single pulse for each half cycle, with the pulse width being adjusted to regulate the output voltage of the inverter. Gating signals are produced by comparing a rectangular reference signal of amplitude  $E_r$  with a triangular carrier wave of amplitude  $E_c$ . The control variable is defined as the amplitude modulation index, which represents the ratio of  $E_r$  to  $E_c$ .

#### b. Multiple Pulse Width Modulation (MPWM)

In this modulation technique, the harmonic content is minimized by employing multiple pulses within each half cycle of the output voltage. Gating signals, which facilitate the activation or deactivation of a thyristor, are produced by comparing a reference signal with a triangular carrier wave. The carrier frequency, denoted as  $f_c$ , dictates the number of pulses per half cycle, represented as  $m$ , while the frequency of the reference signal establishes the output frequency,  $f_0$ . The modulation index plays a crucial role in regulating the output voltage. This modulation approach is referred to as Symmetrical Pulse Width Modulation.

#### c. Sinusoidal Pulse Width Modulation

In this modulation technique, multiple pulses are utilized within each half cycle, similar to the approach taken in MPWM. However, unlike MPWM, where all pulse widths remain constant, this method varies the width of each pulse in proportion to the amplitude of a sine wave assessed at the midpoint of the respective pulse. Gating signals are produced by comparing a sinusoidal reference signal with a triangular carrier wave of frequency,  $f_c$ . The frequency of the reference signal,  $f_r$ , dictates the output frequency of the inverter,  $f_0$ , while its peak amplitude,  $E_r$ , influences the modulation index, subsequently affecting the RMS output voltage.

## 4. Enhanced Modulation Method

### a. Trapezoidal modulation:

It involves the comparison of a triangular carrier wave with a reference trapezoidal wave, which results in the generation of switching instances for semiconductor devices. This modulation

technique enhances the peak fundamental output voltage; however, the output voltage exhibits lower-order harmonics, as illustrated in Fig 3 [10].

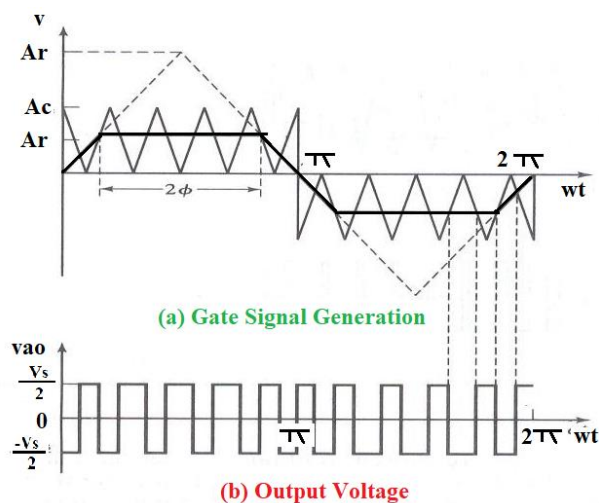

Fig. 3 Modulation of trapezoidal

**b. Modulation of Staircase:**

Staircase pulse width modulation (PWM) effectively removes certain harmonics from the modulated waveform. To achieve the desired output voltage quality, the modulation frequency ratio and the number of steps are selected, as illustrated in Figure 3. When the number of pulses is fewer than 15 per cycle, this represents optimized pulse width modulation.

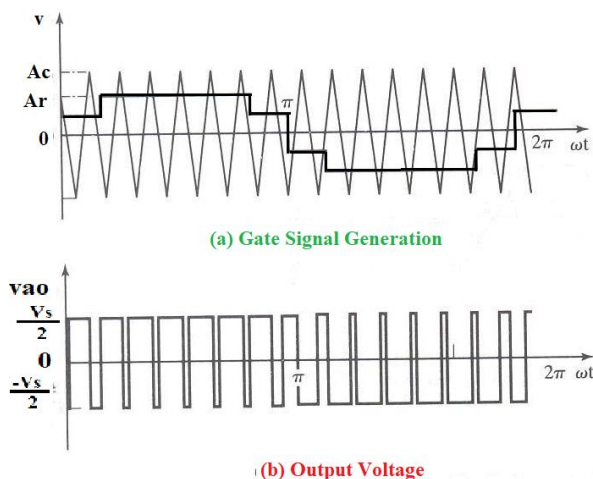

Fig. 4 Modulation of Staircase

**c. Stepped modulation:**

This modulation technique utilizes a stepped wave signal, as illustrated in Fig. 5. To regulate the amplitude of the fundamental components and to suppress certain harmonics, the wave is segmented into distinct intervals, with each interval being managed independently.

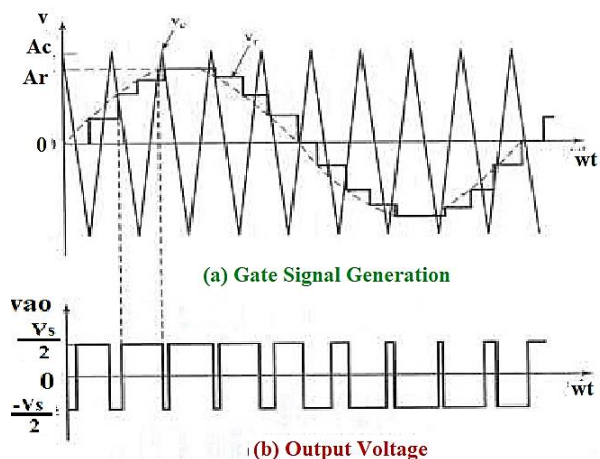

Fig.5 Modulation of stepped

**d. Modulation of Harmonic Injected:**

This modulation technique utilizes a stepped wave signal, as illustrated in Fig. 5. To regulate the amplitude of the fundamental components and to suppress certain harmonics, the wave is segmented into distinct intervals, with each interval being managed independently.

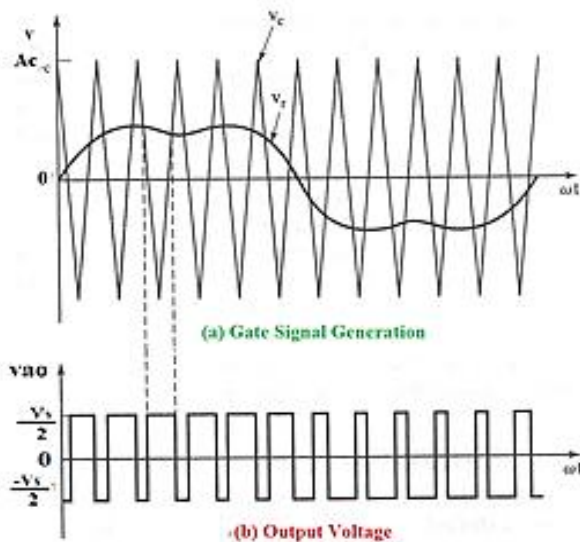

Fig. 6 Modulation of Harmonic Injected

**e. Modulation of Delta:**

In this modulation, a triangular wave is permitted to fluctuate within a specified range above and below the reference wave

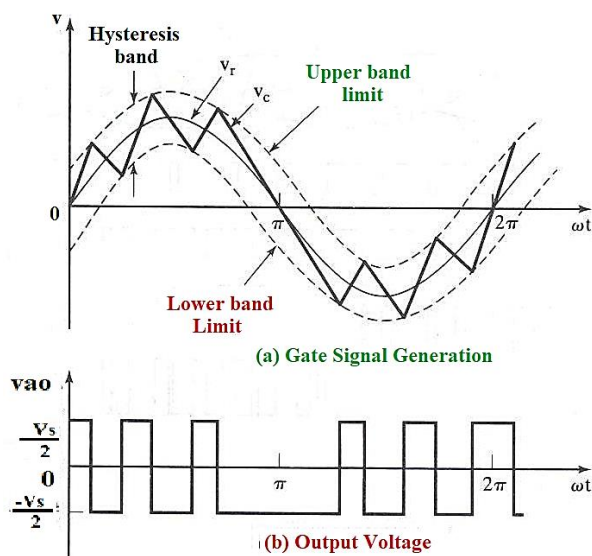

Fig. 7 Modulation of Delta

A significant challenge encountered in PWM schemes is the minimization of harmonic content within the voltage waveforms produced by inverters. Over the past thirty years, extensive research has led to the development of various techniques, including Newton-Raphson iteration methods and those based on genetic algorithms, aimed at optimizing switching. Among the prevalent approaches is the selective harmonic elimination technique, which operates at the fundamental frequency. This method involves solving transcendental equations that describe harmonics using the Newton-Raphson method to determine the optimal switching angles.

## 5. Unit Vector Template (UVT)

The fundamental system block diagram utilizing the UVT (Unit Vector Template) method is depicted in Fig 9 [11]. The SAF functions as a device connected in parallel, effectively canceling out the harmonic and reactive currents produced by a nonlinear load. Consequently, the total current drawn from the main AC source exhibits a sinusoidal waveform. Ideally, the Active Filter (AF) must produce only the necessary harmonic current to offset the nonlinear loads present in the circuit. An active filter, which is a current-controlled Voltage Source Inverter (VSI), is employed to generate the compensating current, which is then injected into the main power supply line.

The compensating current serves to neutralize the harmonic components produced by the nonlinear load, thereby maintaining the sinusoidal nature of the main line current. The first expression pertains to the load reference currents, which are generated using a Phase Locked Loop (PLL). The control scheme of the system relies on the extraction of the Unit Vector Template (UVT) from the distorted input supply. This method effectively transforms the signal into a pure sinusoidal waveform with a unity amplitude. The shunt active filter compensates for current harmonics by introducing an equal but opposite harmonic compensating current. In this scenario, the shunt active filter operates as a current source, injecting the necessary harmonic components.

The control strategy serves as the primary method for generating reference signals for the Shunt Active Filter (SAF). The effectiveness of the SAF's compensation is contingent upon its capacity to

accurately follow reference signals with minimal time delay and error, thereby addressing distortions, unbalanced currents, voltages, or any other imbalances. Various control techniques are typically employed in Shunt Active Filters, with the UVT (Unit Vector Template) technique being utilized in the current study. As illustrated in Figure 10, the reference current signal for the Shunt Active Filter is generated within this framework. In this system, a Proportional Integral (PI) controller is implemented to ensure synchronization with the supply voltage. The fundamental principle behind the three-phase voltage reference signal for the Shunt Active Filter is derived from the UVT approach, which is realized through the use of the Proportional Integral controller.

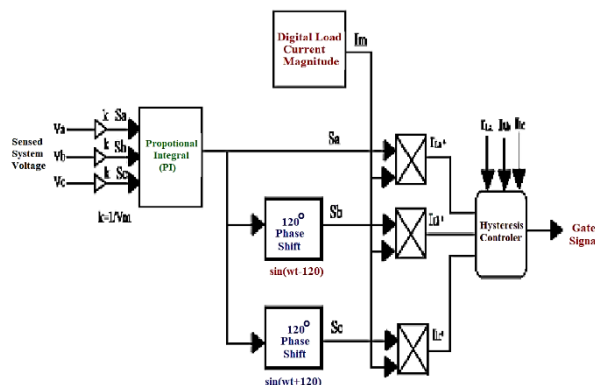

Figure 10 Control Strategy of UVT

Following the extraction of the three-phase voltage reference signal, the reference load voltage signals can be obtained by multiplying the peak amplitude of the fundamental input voltage with the unit vector template as described in equation (2).:

$$V^*L_{abc} = V_m * S_{abc} \tag{2}$$

In the hysteresis controller, the reference load voltage ( $V^*L$ ) is set equal to the sensed load voltage ( $V_L$ ) in order to produce switching signals for the shunt active filter's switches.

### 5.1 PI control Arrangement

Illustrate in figure 11 general block diagram of the proposed PI control scheme of an Shunt SAF. In this system the sensed voltage from the system is compared with a reference value and obtained error  $e=V_{dc,ref} - V_{dc}$  at the nth sampling immediate is used as input for PI controller

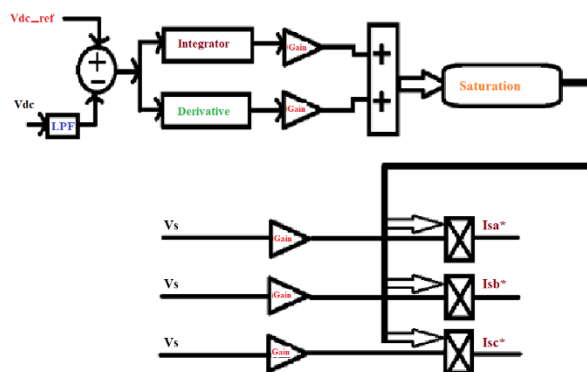

Fig. 11 Basic Control Arrangement of PI controller

The transfer function of a proportional integral controller can be expressed as.:

$$H(s)=K_P+K_I/s \quad (3)$$

In this context,  $K_p$  represents the proportional constant that characterizes the dynamic response of voltage control, while  $K_I$  denotes the integration constant that determines the settling time. The proportional-integral controller is employed to eliminate the steady-state error in direct current (DC) voltage. Within the PI Controller, the proportional gain and integral gain are configured in such a manner that the output voltage,  $V_{dc}$ , closely approximates the reference value of  $V_{dc}$  [15].

## 6. Conclusion

This document discusses a harmonic mitigation technique utilizing the Shunt Active Filter (Shunt AF) to enhance electric power quality at the distribution level. The Shunt AF effectively addresses power quality challenges associated with load currents, including reactive current, unbalance, harmonics, and neutral current. The paper examines harmonic-related issues through the application of the Shunt Active Power Filter (Shunt APF). Among the two techniques analyzed, the Unbalanced Voltage Technique (UVT) demonstrates superior performance. The benefits of the UVT method include reduced computational requirements, lower switching losses, minimal memory usage, and significantly higher speed compared to alternative methods.

## References

- [1] W.M. Grady, M.J. Samotyj, A.H. Noyola, Survey of active power line conditioning methodologies, *IEEE Trans. Power Delivery* 5 (3) (1990) 1536–1542.
- [2] H. Akagi, New trends in active filter for improving power quality, in: *Proceedings of the 1996 International Conference on Power Electronics, Drives and Energy System for Industrial Growth*.
- [3] Hideaki Fujita and Hirofumi Akagi, member, IEEE, “A Practical Approach to Harmonic Compensation in a Power System-series connection of passive and active filter”, *IEEE Transactions On Industrial Applications*, vol. 27, no.6, November/December 1991.
- [4] J.S. Tepper, W. Juan, J.W. Dixon, A simple-frequency independent method for calculating the reactive and harmonic current in a nonlinear load, *IEEE Trans. Ind. Electron.* 43 (6) (1996).
- [5] Nakata, A. Ueda, A. Torii, A method of detection for an active power filter applying moving average to pq-theory, *IEEE PESC 98 Record*.
- [6] M. Aziz, Vinod Kumar, Aasha Chauhan, Bharti Thakur, “Power Quality improvement by Suppression of Current Harmonics Using Hysteresis Controller Technique”, *International Journal of Recent Technology and Engineering (IJRTE)* ISSN: 2277-3878, Volume-2, Issue-2, May 2013.
- [7] Bhim Singh, Kamal Al-Haddad, “A Review of Active Filters for Power Quality Improvement”, *IEEE Transactions on Industrial Electronics*, Vol. 46, No. 5, October 1999
- [8] K. Gurumoorthy, D. Prince Wilson, D. Edison Selvaraji and Lieutenant J. Ganesan ‘reduction of harmonics by applying various PWM and neutral network techniques in grid connected photovoltaic systems’ vol.2, Issue 12, December 2013.
- [9] Sunil Pande, Anupam Mishra, B. Srinivas under the guidance of Prof. B. Ghitti Babu. ‘control of voltage source inverter using PWM/SVPWM for adjustable speed drive application’
- [10] Satish Kumar Peddapelli. ‘recent advances in the pulse width modulation techniques and multilevel inverter’ world academy of science, engg and technology. vol-8 no:3 2014
- [11] Rama Rao and Dr. Subhansu Sekhar Dash, “Power Quality Enhancement by Unified Power Quality Conditioner Using ANN with Hysteresis Control”, *International Journal of Computer Applications* (0975 – 8887), Volume 6–No.1, September 2010.

- [12] Vadirajacharya. K., Pramod Agrawal, H. O. Gupta, “Control of current-Source Active Power Filter Using Unit Vector Template In Three Phase Four Wire Unbalanced System”, PEDS 2007.
- [13] V.Khadkikar, A.Chandra, P.Agarwal, A.O.Barry and T.D.Nguyen, “A Simple New Control Technique For Unified Power Quality Conditioner (UPQC)”, International Conference on Harmonics and Quality of Power, 2010.
- [14] S. Srinath, M.P.Selvan, K.Vinothkumar, “Comparative Evaluation of Performance of Different Control Strategies on UPQC Connected Distribution System”, 5th International Conference on Industrial and Information Systems (ICIIS), July 29 -Aug. 01, 2010.
- [15] Karuppanan P and Kamala Kanta Mahapatra, “PI, PID and Fuzzy logic controller for Reactive Power and Harmonic Compensation”, National Institute of Technology-Rourkela, India-769008