

## “Impact of Distributed Generation on Voltage Stability and Losses in Radial Distribution Networks”

Pawan Kumar Verma<sup>1</sup>, Dr. Manoj Kumar Nigam<sup>2</sup>, Sandeep Roy<sup>3</sup>

<sup>1</sup>Research Scholar, Kalinga University, Raipur, C.G., India

*pawancsit42@gmail.com*

<sup>2</sup>Professor & HOD, Kalinga University, Raipur, C.G., India

*manoj.nigam@kalingauniversity.ac.in*

<sup>3</sup>Assistant Professor, Kalinga University, Raipur, C.G., India

*sandeep.roy@kalingauniversity.ac.in*

### Article History:

**Received:** 12-01-2025

**Revised:** 15-02-2025

**Accepted:** 01-03-2025

### Abstract:

The increasing need for enhanced power quality drives modern industry. In the last ten years, there has been a significant rise in consumer awareness regarding dependable power sources. As a result, the growth of small distributed generation (DG) has accelerated. These small, independent DG units can effectively meet local energy demands, improving power reliability at a low initial cost. Such systems are becoming increasingly essential in remote areas where the installation of overhead lines or cables is either too costly or impractical due to various factors. Small generation systems can be efficiently deployed in mountainous regions, rural areas, islands, marine facilities, aircraft, and other locations, including in developing countries. However, it is important to note that these DG units may need to be de-rated if induction motor loads are engaged immediately. A useful strategy to optimize the overall production capacity of the system is to integrate a DSTATCOM in a shunt configuration with the main system. The voltage source converter (VSC) generates the necessary inductive and capacitive reactive power for the DSTATCOM internally. Its rapid response capability can provide suitable reactive power compensation to the connected system.

Prior to the introduction of DSTATCOM, reactive power compensation was primarily achieved through thyristor-based systems, which were employed to mitigate voltage flicker caused by arc furnace loads. However, due to the inherent limitations of passive devices—such as fixed compensation, physical size, and susceptibility to resonance—there has been a growing reliance on advanced compensators like DSTATCOM to effectively tackle these power quality challenges. DSTATCOM serves as a viable solution for addressing power quality issues related to flickers, voltage swells, and dips. Its primary function is to manage voltage levels at the point of common coupling (PCC) to prevent significant voltage drops.

**Keywords:** Distributed generation, effects, solar power, DSTATCOM.

## I. INTRODUCTION

In today's context, distributed generation has become a focal point for researchers and engineers due to its advantages, particularly as traditional energy sources disrupt ecological balance and pose health risks through their byproducts, such as fly ash [1]. To address the adverse effects on the environment,

it is essential to investigate these finite non-renewable resources. Distributed generation technology provides several advantages:

1. It supports voltage stability and improves power quality while generating minimal pollution and can be deployed at any preferred location [2].
2. It does not disrupt ecological balance [3].
3. It enhances the reliability of the utility system [4].
4. It can be installed based on production capacity requirements [5].
5. It reduces losses [6].

However, despite its numerous benefits, distributed generation also presents certain limitations for the distribution network:

1. It can disrupt stability [7].
2. It may negatively impact system performance [8].
3. It can shorten the lifespan of connected devices [9].
4. It tends to increase power losses [10].

When distributed generation (DG) is integrated into the distribution network, its effects are intensified. The primary drawback of this system is its significant unreliability and susceptibility to noise interference [7]. A radial distribution network functions as a power plant, consisting of a central power generation facility that delivers energy to remote substations and ultimately to consumers. The incorporation of a relatively large capacity DG into a weak distribution network may lead to an increase in voltage, especially during periods of low demand [6]. As the capacity of DG installations rises, their influence on the behavior of the power system will become more pronounced, necessitating comprehensive dynamic analysis and simulations to ensure the reliable operation of the power system with substantial DG integration [3]. Presently, the effects of DG on electric utilities are generally evaluated in planning studies through traditional power flow calculations, which is a reasonable approach given that the penetration levels of DG remain relatively low [5]. In this regard, further research has been undertaken to enhance the field, particularly to mitigate the impacts of DG. As outlined in various studies, several techniques have been utilized, including optimal power flow methods, particle swarm optimization, ant colony optimization, genetic algorithms, and Monte Carlo simulation methods [2], [4], [8]. This paper employs MATLAB's Power System Analysis Tool (PSAT) to model the IEEE 30 bus test network [10].

The primary focus of this study is the 11kV 100MVA radial distribution network. Buses 29 and 30 have been linked to wind-dispersed generators with capacities of 68 MVA at 11kV and 50 MVA at 11kV, respectively, due to their heightened sensitivity. This section provides a brief introduction to distributed generation, along with a comprehensive overview of the work completed. The methodology section outlines the application of the proposed approach for analyzing an IEEE-30 bus network. The results section presents the comparative performance of the network and the positioning of distributed generation.

## II. METHODOLOGY

The IEEE-30 bus network with distributed generation (DG) connected, as shown in Fig. 2, and the IEEE-30 bus network without DG, illustrated in Fig. 1, were analyzed using the PSAT 2.1.7 software. The PSAT includes several analytical tools:

1. Continuation power flow.
2. Optimal power flow.
3. Time domain analysis.
4. Small signal stability analysis.

The PSAT library encompasses transmission lines, buses, transformers, wind distributed generation, FACT devices, and various other static and dynamic components for power flow analysis.

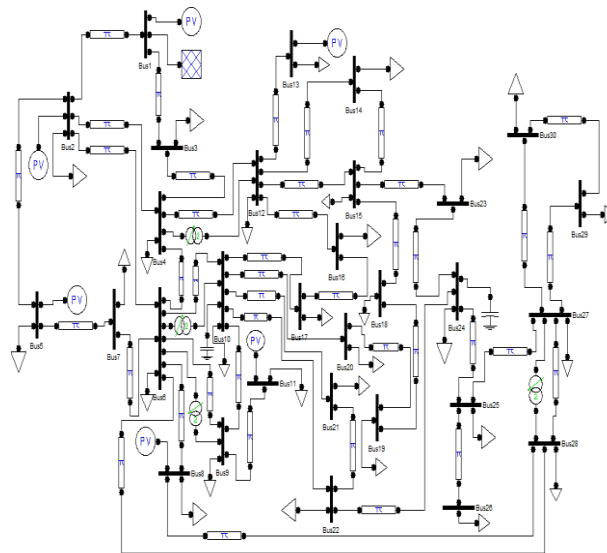

**Figure 1. IEEE-30 bus network without DG connected**

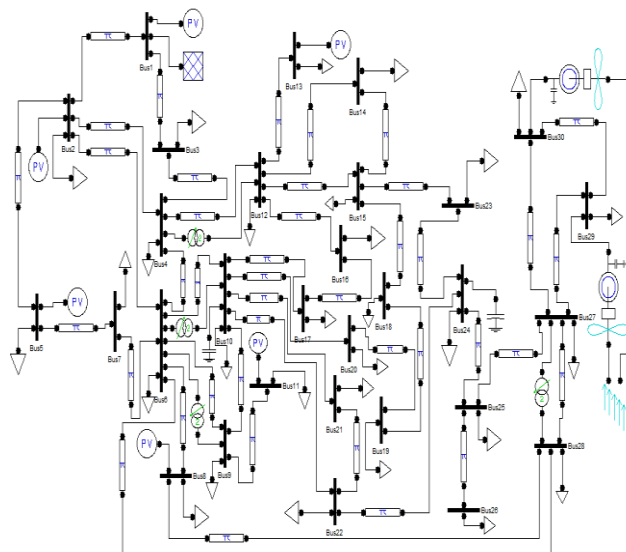

**Figure 2. IEEE-30 bus network with DG connected**

To identify the optimal placement for distributed generation, it is essential to consider its impact on feeder losses. By strategically positioning distributed generation units, losses can be minimized, akin to the placement of capacitor banks for loss reduction. The key difference lies in the fact that distributed generation units influence both reactive and real power flows, whereas capacitors only affect reactive power. While some inverter technologies can provide reactive compensation, most generators typically operate within a power factor range of 0.85 lagging to 1.0. The most suitable connection point for distributed generation is at the weakest node, where the highest voltage drop occurs. Although connections can be made at buses 26 and 29 if required, our analysis indicates that bus 30 is the weakest bus in this context.

### III. RESULTS AND DISCUSSION

This section discusses the outcomes of the continuation power flow simulation for the IEEE-30 bus system under two scenarios: without Distributed Generation (DG) and with DG connected at Buses 29 and 30.

#### A. Power Flow Results without DG

The continuation power flow analysis for the base system, without DG, yields the results shown in Table I.

**Table I. Power Flow Result without DG Connected**

| Bus | Q Load [p. u.] | Bus | Q Load [p. u.] |
|-----|----------------|-----|----------------|
| 1   | 0.00000        | 16  | 0.05914        |
| 2   | 0.41728        | 17  | 0.19057        |
| 3   | 0.03943        | 18  | 0.02957        |
| 4   | 0.05257        | 19  | 0.11171        |
| 5   | 0.62428        | 20  | 0.02300        |
| 6   | 0.00000        | 21  | 0.36800        |
| 7   | 0.35814        | 22  | 0.00000        |
| 8   | 0.98571        | 23  | 0.05257        |
| 9   | 0.00000        | 24  | 0.20274        |
| 10  | -0.04854       | 25  | 0.00000        |
| 11  | 0.00000        | 26  | 0.07557        |
| 12  | 0.24643        | 27  | 0.00000        |
| 13  | 0.00000        | 28  | 0.00000        |
| 14  | 0.05257        | 29  | 0.02957        |
| 15  | 0.08214        | 30  | 0.06243        |

**B. Power Flow Results with DG Connected**

When wind-based DGs are added at Buses 29 (68 MVA) and 30 (50 MVA), the system behavior changes marginally, as seen in Table II.

**Table II. Power Flow Result with DG Connected**

| Bus | Q Load [p. u.] | Bus | Q Load [p.u.] |
|-----|----------------|-----|---------------|
| 1   | 0.00000        | 16  | 0.05913       |
| 2   | 0.41718        | 17  | 0.19052       |
| 3   | 0.03942        | 18  | 0.02956       |
| 4   | 0.05256        | 19  | 0.11169       |
| 5   | 0.62412        | 20  | 0.02299       |
| 6   | 0.00000        | 21  | 0.36790       |
| 7   | 0.35805        | 22  | 0.00000       |
| 8   | 0.98546        | 23  | 0.05256       |
| 9   | 0.00000        | 24  | 0.20271       |
| 10  | -0.04850       | 25  | 0.00000       |
| 11  | 0.00000        | 26  | 0.07555       |
| 12  | 0.24636        | 27  | 0.00000       |
| 13  | 0.00000        | 28  | 0.00000       |
| 14  | 0.05256        | 29  | 0.02956       |
| 15  | 0.08212        | 30  | 0.06241       |

**C. Summary of Load Flow Simulations**

| Metric               | Without DG | With DG | Difference |
|----------------------|------------|---------|------------|
| Total Generation (P) | 13.9588    | 13.9605 | +0.0017    |
| Total Generation (Q) | 20.1380    | 20.1497 | +0.0117    |
| Total Load (P)       | 9.3117     | 9.3093  | -0.0024    |
| Total Load (Q)       | 4.0149     | 4.0139  | -0.0010    |
| Total Losses (P)     | 4.6471     | 4.6512  | +0.0041    |
| Total Losses (Q)     | 16.1231    | 16.1358 | +0.0127    |

While DG integration helps support local loads and slightly reduces the burden on the main grid, the results show a marginal increase in overall power losses. This could be attributed to reactive power mismatch and sub-optimal DG placement.

#### D. Reactive Power Loss Comparison

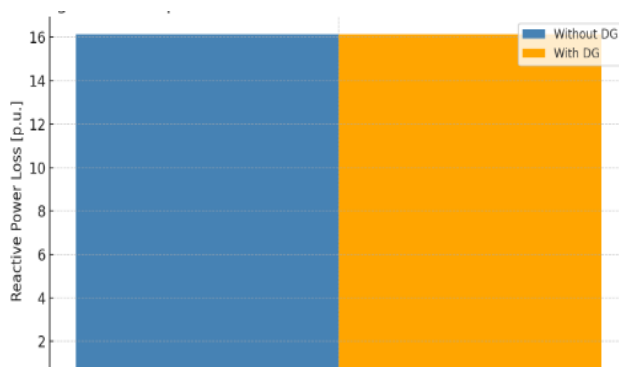

**Figure 3. Comparison of Reactive power loss with and without DG**

Figure 3 showing the comparison of total reactive power losses with and without DG connected. The difference is slight, highlighting that while DG supports local demands, it may cause small inefficiencies if not optimally controlled or placed.

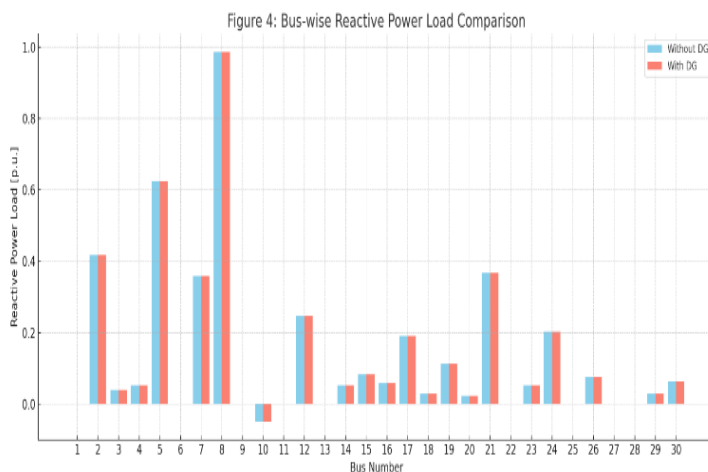

**Figure 4. Bus wise reactive Power load comparison**

Figure 4, which compares the reactive power load at each bus with and without distributed generation (DG). As shown, the differences are minimal but noticeable at select buses—especially those connected to DG (e.g., Bus 29 and Bus 30).

#### IV. CONCLUSION

A radial distribution network has been employed to examine the impact of distributed generation (DG) on the IEEE-30 bus system. This research involved the incorporation of wind-based DG units at Buses 29 and 30, with capacities of 68 MVA and 50 MVA at 11kV, respectively, into an 11kV 100 MVA distribution network. The evaluation of reactive power loads, as illustrated in Table I and Figure 3, indicates that the integration of DG influences the reactive power equilibrium of the network. While DG contributes additional local generation and enhances voltage profiles, it also

causes fluctuations in reactive power flow, resulting in a slight increase in reactive power losses as evidenced by the simulation outcomes. These alterations, although minor, emphasize the sensitivity of network stability and the critical nature of strategic DG placement. Moreover, pinpointing the weakest nodes—those exhibiting considerable load or reactive imbalance—offers a strategy for optimal DG placement. For instance, Bus 30 displays traits of a weak node, rendering it an appropriate candidate for DG connection. This focused integration enhances localized reliability and voltage support but necessitates meticulous power flow analysis to prevent negative impacts on the overall system. Consequently, the incorporation of DG has a profound effect on network stability and overall reliability, underscoring the necessity for dynamic assessment tools and optimal placement strategies to guarantee the effective use of distributed resources.

## REFERENCES

- [1] H. Rahman, “IEEE 30 bus system using PSAT,” MATLAB Central File Exchange, 2023. [Online].
- [2] M. H. Moradi and M. Abedini, “A combination of genetic algorithm and particle swarm optimization for optimal DG location and sizing in distribution systems with fuzzy optimal theory,” *Int. J. Green Energy*, vol. 9, no. 7, pp. 641–660, 2012.
- [3] A. Agalgaonkar, S. V. Kulkarni, S. A. Khaparde, and S. Soman, “Placement and penetration of distributed generation under standard market design,” *Int. J. Emerg. Electr. Power Syst.*, vol. 5, no. 2, pp. 1–23, 2004.
- [4] O. Badran, “Loss minimization and voltage enhancement through DGs generation and sittings considering TCA in network reconfiguration during load-variation,” *Energy Reports*, vol. 9, pp. 5031–5042, 2024.
- [5] R. S. Rao, K. Ravindra, K. Satish, and S. Narasimham, “Power loss minimization in distribution system using network reconfiguration in the presence of distributed generation,” *IEEE Trans. Power Syst.*, vol. 28, no. 1, pp. 317–325, Feb. 2013.
- [6] K. R. Guerliche and T. Bouktir, “Optimal allocation and sizing of distributed generation with particle swarm optimization algorithm for loss reduction,” *Rev. Sci. Technol.*, vol. 6, pp. 59–69, 2015.
- [7] Y. Rahman, A. Siswanto, and I. Mahmudi, “Impact of distributed generations on power systems stability: A review,” *Renew. Sustain. Energy Rev.*, vol. 88, pp. 103–115, 2018.
- [8] A. Fazliana Abdul Kadir, A. Mohamed, H. Shareef, M. Z. Che Wan, and A. A. Ibrahim, “Optimal Sizing and Placement of Distributed Generation in Distribution System Considering Losses and THDv using Gravitational Search Algorithm,” *Przegląd Elektrotechniczny*, vol. 89, no. 4, pp. 132–136, 2013. [pe.org.pl](http://pe.org.pl)
- [9] K. R. Guerliche and T. Bouktir, “Optimal allocation and sizing of distributed generation with particle swarm optimization algorithm for loss reduction,” *Revue des Sciences et Technologies*, vol. 6, pp. 59–69, 2015.
- [10] Y. Rahman, A. Siswanto, and I. Mahmudi, “Impact of distributed generations on power systems stability: A review,” *Renewable and Sustainable Energy Reviews*, vol. 88, pp. 103–115, 2018.

- [11] S. K. Khadem, M. Basu, and M. F. Conlon, "Power quality in grid connected renewable energy systems: Role of custom power devices," *Int. J. Electr. Power Energy Syst.*, vol. 39, no. 1, pp. 33–41, Jul. 2012.
- [12] A. E. Eajal, M. E. El-Hawary, and M. M. A. Salama, "Optimal capacitor placement and sizing in radial distribution systems with uncertainties in load and DG outputs using hybrid DE–PSO algorithm," *Electr. Power Syst. Res.*, vol. 124, pp. 1–12, Jul. 2015.
- [13] S. S. Reddy, "Optimal placement of distributed generation using hybrid grey wolf optimizer," *Int. J. Electr. Power Energy Syst.*, vol. 82, pp. 264–274, Nov. 2016.
- [14] H. A. Gil and G. Joos, "Models for quantifying the economic benefits of distributed generation," *IEEE Trans. Power Syst.*, vol. 23, no. 2, pp. 327–335, May 2008.
- [15] N. Acharya, P. Mahat, and N. Mithulananthan, "An analytical approach for DG allocation in primary distribution network," *Int. J. Electr. Power Energy Syst.*, vol. 28, no. 10, pp. 669–678, Dec. 2006.
- [16] M. Gandomkar, M. Vakilian, and M. Ehsan, "A combination of genetic algorithm and simulated annealing for optimal DG allocation in distribution networks," *Can. J. Electr. Comput. Eng.*, vol. 33, no. 3, pp. 149–152, 2008.
- [17] A. Ulinuha, M. M. Yusoff, and T. K. A. Rahman, "Optimal distributed generation allocation and sizing using improved particle swarm optimization," *Int. Rev. Electr. Eng.*, vol. 6, no. 6, pp. 2974–2983, Dec. 2011.
- [18] T. Ackermann, G. Andersson, and L. Söder, "Distributed generation: A definition," *Electr. Power Syst. Res.*, vol. 57, no. 3, pp. 195–204, Apr. 2001.
- [19] P. Chiradeja and R. Ramakumar, "An approach to quantify the technical benefits of distributed generation," *IEEE Trans. Energy Convers.*, vol. 19, no. 4, pp. 764–773, Dec. 2004.
- [20] M. Baran and F. Wu, "Optimal capacitor placement on radial distribution systems," *IEEE Trans. Power Deliv.*, vol. 4, no. 1, pp. 725–734, Jan. 1989.
- [21] M. M. Aman, G. B. Jasmon, H. Mokhlis, and A. H. A. Bakar, "Optimal placement and sizing of a DG based on a new power stability index and line losses," *Int. J. Electr. Power Energy Syst.*, vol. 43, no. 1, pp. 1296–1304, Dec. 2012.
- [22] M. Fotuhi-Firuzabad and S. M. T. Bathaee, "Reliability improvement of distribution systems using distributed generation," *Proc. 7th Int. Conf. Probab. Methods Appl. Power Syst.*, Sep. 2002.
- [23] S. Bahramirad, W. Reder, and A. Khodaei, "Reliability-constrained optimal sizing of energy storage system in a microgrid," *IEEE Trans. Smart Grid*, vol. 3, no. 4, pp. 2056–2062, Dec. 2012.
- [24] T. Niknam, R. Azizipanah-Abarghooee, and M. R. Narimani, "An efficient scenario-based stochastic programming framework for multi-objective optimal micro-grid operation," *Appl. Energy*, vol. 99, pp. 455–470, Nov. 2012.
- [25] M. S. Bhatt and V. Mukherjee, "A novel approach for optimal allocation and sizing of distributed generation in radial distribution system using fireworks algorithm," *Int. J. Electr. Power Energy Syst.*, vol. 80, pp. 37–52, Sep. 2016