

Intelligent Hybrid EV Energy Management: Leveraging Real-Time Data for Efficient Power Utilization

Sasirekha P

Assistant Professor,
Department of Electrical and Electronics Engineering,
M.Kumarasamy College of Engineering,
Karur, India,
sasirekhap.eee@mkce.ac.in

Sivaranjani P

M.E Power Systems Engineering,
Department of Electrical and Electronics Engineering,
M.Kumarasamy College of Engineering,
Karur, India,
siva97pooja@gmail.com

Article History:

Received: 12-01-2025

Revised: 15-02-2025

Accepted: 01-03-2025

ABSTRACT-Intelligent Energy Management Systems (IEMS) play a pivotal role in enhancing the performance and sustainability of Hybrid Electric Vehicles (HEVs). By integrating renewable energy sources like solar panels and wind generators, these systems reduce dependency on fossil fuels and promote cleaner transportation solutions. Advanced control techniques and machine learning algorithms enable the system to adapt to real-time driving conditions, traffic patterns, and weather variations, optimizing energy distribution and minimizing waste. Key components such as voltage regulators, relays, and boost converters stabilize power flow and protect sensitive elements like batteries and motors. An Arduino controller intelligently manages energy input from various sources, while an LCD display provides real-time feedback on system performance, empowering drivers with crucial operational insights. The solar panel and wind generator dynamically charge the battery, and filters ensure high-quality power delivery. The motor efficiently converts stored electrical energy into mechanical motion, driving the vehicle forward with enhanced range and reduced emissions. Together, these components work in synergy to maximize energy efficiency, prolong battery life, and contribute to a sustainable future. As HEVs continue to evolve, IEMS innovations will be instrumental in accelerating the transition toward smarter, more efficient, and eco-friendly transportation.

Keywords: Intelligent Energy Management System, Hybrid Electric Vehicle, Renewable Energy, Solar Panel, Wind Generator, Voltage Regulator, Arduino Controller, Boost Converter, Battery, Motor, Energy Efficiency, Sustainability, Real-time Optimization, Green Transportation

I.INTRODUCTION

The rapid evolution of the automotive industry toward electrification and sustainable practices has driven significant advancements in vehicle energy management. Hybrid Electric Vehicles (HEVs) represent a crucial step in this transition, as they combine internal combustion engines

with electric propulsion systems to optimize energy usage and reduce environmental impact. At the core of this innovation lies the Intelligent Energy Management System (IEMS), which orchestrates the dynamic distribution of energy from multiple sources to enhance vehicle efficiency and performance.[1] An IEMS leverages advanced control techniques and machine learning algorithms to continuously learn from driving behaviors, traffic patterns, and external conditions such as weather and terrain. This adaptive capability enables real-time optimization of energy flow, ensuring that the vehicle uses the most efficient power source under varying circumstances.[6] By intelligently balancing energy input from renewable sources, such as solar panels and wind generators, with battery storage and motor demands, the system minimizes energy waste and extends the vehicle's range. Renewable energy integration is a defining feature of modern HEV architectures. Solar panels and wind turbines convert natural energy into usable electricity, reducing reliance on fossil fuels and lowering greenhouse gas emissions. Voltage regulators and filters stabilize fluctuating power inputs, protecting sensitive components like the battery and motor from damage.[9] Boost converters further enhance system efficiency by regulating voltage to maintain optimal power delivery. Central to the energy management process is the Arduino controller, which executes predefined logic to manage energy source selection and distribution. Relays act as control mechanisms, directing energy flow to the appropriate components, while an LCD display provides real-time feedback, enabling users to monitor system performance and make informed decisions about energy usage. As the push for cleaner transportation intensifies, the importance of intelligent control systems in HEVs cannot be overstated.[10] An IEMS not only improves fuel economy and reduces emissions but also paves the way for more autonomous and self-sustaining vehicle systems. With ongoing advancements in renewable technologies and control algorithms, HEVs equipped with sophisticated IEMS solutions are poised to become a cornerstone of the future automotive landscape, contributing to a more sustainable and energy-efficient world.

II.RELATED WORK

Sanguesa, J. A., et al. This study provides a thorough review of electric vehicle (EV) technologies and the key challenges affecting their widespread adoption. The authors discuss battery innovations, energy management systems, and advancements in charging infrastructure. The paper emphasizes the role of policy support and smart grid integration in promoting EVs. It also highlights the need for sustainable solutions to address environmental concerns, production costs, and resource limitations. The research offers insights into future trends and potential strategies for accelerating the transition to electric mobility. [1]

Tran, D.-D., et al. The research explores electric and hybrid vehicle powertrains, detailing various architectures and integrated energy management strategies. The authors present a comparative analysis of topologies like series, parallel, and power-split configurations. They examine how real-time control algorithms optimize energy usage, balancing battery longevity with performance. The study underscores the importance of multi-objective optimization to enhance fuel efficiency and reduce emissions. This work serves as a valuable reference for designing next-generation powertrain systems that meet evolving transportation demands. [2]

Casper, R., & Sundin, E. This paper investigates the impact of vehicle electrification on the remanufacturing industry, focusing on sustainability and circular economy practices. The authors discuss how electric drivetrains affect component wear, disassembly processes, and material recycling. They emphasize the need for adaptive remanufacturing techniques to handle high-voltage systems and advanced electronics. The research highlights potential cost savings and environmental benefits, advocating for policy incentives to promote sustainable practices. The findings provide a roadmap for companies seeking to transition to EV-focused remanufacturing operations. [3]

Chen, J., Li, M., & Zhang, X. The study presents a detailed model and simulation framework for hybrid electric vehicle (HEV) powertrains, enabling performance evaluation under various driving scenarios. The authors explore subsystem interactions, including motor dynamics, battery behavior, and energy flow. They simulate acceleration, braking, and energy recuperation processes to assess efficiency and responsiveness. The results offer valuable insights into optimizing powertrain configurations to balance energy consumption, vehicle range, and driving comfort. This work helps engineers refine HEV designs and accelerate the development process. [4]

Kumar, S., Sharma, A., & Gupta, P. The authors propose an optimized energy management strategy for plug-in hybrid electric vehicles (PHEVs), focusing on reducing emissions and improving energy efficiency. They develop an intelligent control algorithm that dynamically switches between battery and fuel modes based on real-time driving conditions. The strategy optimally allocates power to minimize fuel consumption while extending battery life. The research demonstrates significant efficiency gains through simulations, highlighting the potential for real-world applications. This approach contributes to creating more sustainable and cost-effective PHEV systems. [5]

Lee, K., & Park, H. This paper explores the design and control of battery charging systems in hybrid electric vehicles (HEVs). The authors propose advanced charging algorithms that optimize charging speed, safety, and energy efficiency. They analyze factors like thermal management, voltage regulation, and state-of-charge estimation to prevent battery degradation. The research also investigates bidirectional charging for vehicle-to-grid applications, enhancing grid resilience. The findings provide practical guidelines for developing smart charging infrastructure and improving user convenience, paving the way for a more sustainable transportation ecosystem. [6]

Wang, T., Zhang, L., & Li, Q. The study investigates control strategies for regenerative braking in hybrid electric vehicles, focusing on energy recovery and braking stability. The authors explore methods for maximizing energy capture during deceleration while maintaining vehicle control. They present algorithms that dynamically adjust braking force distribution between mechanical and electric systems. Simulations demonstrate improved energy efficiency and reduced wear on mechanical components. This research contributes to enhancing EV range and sustainability, offering practical insights for manufacturers aiming to optimize braking performance. [7]

Matharu, H. S., et al. The research outlines the design and deployment of a hybrid electric vehicle (HEV), detailing system architecture, control strategies, and component selection. The authors build a prototype, testing power distribution, motor control, and battery management systems. They analyze performance metrics like acceleration, energy efficiency, and thermal stability. The study provides valuable insights into integrating hardware and software for real-world HEV deployment. The findings serve as a practical guide for engineers and researchers, accelerating the development of more efficient and reliable hybrid vehicles. [8]

Yeole, S. S., et al. This paper presents the design of a two-wheeler hybrid electric vehicle using a series-parallel configuration. The authors detail the vehicle's powertrain architecture, control logic, and energy flow mechanisms. They conduct simulations to assess energy efficiency, battery performance, and system responsiveness. The research highlights the benefits of flexible power modes, balancing electric and fuel power for different driving conditions. The findings offer a blueprint for developing affordable, sustainable urban mobility solutions, contributing to the broader adoption of hybrid technologies in smaller vehicles. [9]

Miller, J. M. The research explores the role of power electronics in hybrid electric vehicle (HEV) applications, highlighting key components like inverters, converters, and motor controllers. The author discusses strategies for optimizing energy conversion, reducing power losses, and improving system reliability. The paper emphasizes the importance of thermal management and fault tolerance in high-power applications. The research lays the foundation for future advancements in EV design, providing essential insights into the interplay between power electronics and vehicle performance. It remains a critical reference for EV engineers and researchers. [10]

III. PROPOSED SYSTEM

The proposed Intelligent Energy Management System (IEMS) for Hybrid Electric Vehicles (HEVs) is designed to optimize energy consumption, enhance system efficiency, and promote sustainable transportation by integrating renewable energy sources with advanced control mechanisms. This system intelligently balances energy input from solar panels, wind generators, and battery storage to ensure optimal vehicle performance under diverse operating conditions.[3]

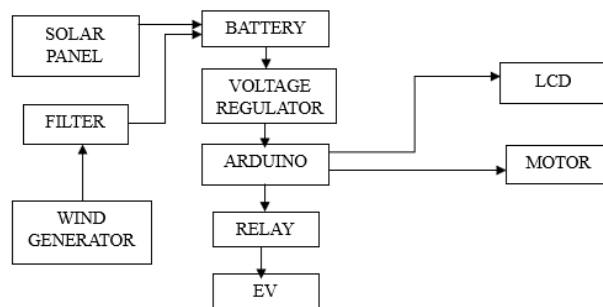

Figure 1. System Architecture

At the heart of the system lies an Arduino controller, responsible for executing predefined control logic to manage energy distribution. The controller continuously monitors energy inputs, battery status, and motor demands to make real-time decisions on the most efficient energy source to utilize. This dynamic control minimizes energy waste and prolongs battery life, enhancing the vehicle's overall longevity and range.[4]

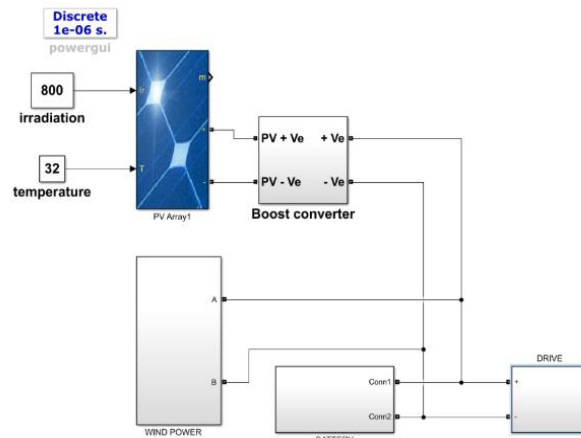

Figure 2. Simulation Diagram of Hybrid Vehicle

The system integrates solar panels and wind generators to harness renewable energy. The solar panels convert sunlight into electricity through the photovoltaic effect, while wind generators transform kinetic wind energy into electrical power. These sources reduce dependence on fossil fuels and contribute to lower carbon emissions.[5]

However, as environmental conditions vary, voltage fluctuations may occur, potentially affecting system stability. To address this, a voltage regulator is employed to maintain a steady power flow, protecting sensitive components like the battery and motor. Relays act as switching devices, enabling seamless transitions between different energy sources. The system activates or deactivates energy sources based on real-time energy requirements, ensuring that power is drawn only when necessary.[7]

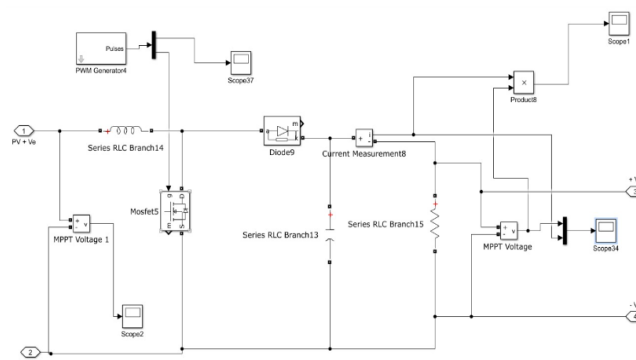

Figure 3. Simulation Diagram of Boost converter

A boost converter steps up the voltage from the battery when higher power is required, improving energy delivery to the motor while preventing over-discharge. Filters are

incorporated to enhance power quality and system reliability. Harmonic filters mitigate unwanted signal distortions from the wind generator, while electromagnetic filters suppress noise, ensuring clean energy reaches the vehicle's components. These measures protect the system from potential damage and contribute to smooth, efficient operations.[8] An LCD display provides real-time feedback on system performance, including energy levels, battery status, and source utilization. This interface empowers the driver with critical information to make informed energy usage decisions, adding an extra layer of operational awareness. Together, these components form a cohesive and adaptive energy management system that optimally utilizes renewable resources, reduces emissions, and improves fuel efficiency. As the transportation industry continues to evolve, such intelligent systems will be vital for the widespread adoption of HEVs, driving progress toward a cleaner and more sustainable future.

IV. METHODOLOGY AND TECHNOLOGIES USED

METHODOLOGIES

A. Renewable Energy Integration

The system integrates solar panels and wind generators to harness renewable energy for hybrid electric vehicles (HEVs). Solar panels convert sunlight into DC electricity, while wind generators transform wind energy into electrical power. This dual-source approach reduces reliance on fossil fuels, promoting sustainability. Energy inputs are dynamically managed based on environmental conditions, with an intelligent controller balancing power distribution. By leveraging natural energy sources, the system minimizes emissions, lowers fuel costs, and extends the vehicle's range, showcasing the potential of sustainable energy in modern transportation.[9]

B. Intelligent Energy Management with Arduino

An Arduino microcontroller serves as the system's core, executing control algorithms to manage energy distribution. It monitors real-time inputs from energy sources, battery status, and motor demands to make adaptive decisions. This intelligent control ensures that energy is drawn from the most efficient source at any given time. By automating source selection, the Arduino optimizes power flow, reduces unnecessary energy consumption, and enhances the vehicle's overall efficiency, contributing to a longer lifespan for components and a more reliable energy management strategy.[8]

C. Power Regulation and Stabilization

The system employs voltage regulators and filters to ensure stable and clean power delivery. Voltage regulators smooth out fluctuations from solar and wind inputs, maintaining a consistent voltage level to protect sensitive components like the battery and motor. Filters, including harmonic and electromagnetic types, mitigate signal distortions and noise, ensuring high-quality power transmission. This methodology enhances system reliability and prevents performance degradation, making the energy management system robust and suitable for real-world, variable conditions.[10]

D. Dynamic Load Balancing with Relays

Relays act as control switches to manage energy flow between components. The system uses relays to activate or deactivate energy sources based on real-time power demands. This dynamic load balancing ensures that the motor receives adequate power without overloading the system. The relay mechanism also prevents unnecessary battery drainage, contributing to energy conservation and system efficiency. By precisely controlling energy flow, this methodology optimizes energy usage, enhances vehicle performance, and maintains system longevity.[2]

TECHNOLOGIES USED

A. Arduino Microcontroller

The Arduino microcontroller is the system's control hub, processing sensor data and executing predefined algorithms to manage energy distribution. Its open-source platform and ease of programming make it ideal for prototyping and real-time decision-making. The Arduino continuously monitors inputs from solar panels, wind generators, and the battery, dynamically adjusting energy flow. Its reliability and flexibility enable precise control, ensuring that the vehicle always uses the most efficient energy source, improving energy utilization and reducing system complexity.[1]

B. Photovoltaic Solar Panels

Photovoltaic (PV) panels convert sunlight into DC electricity, providing a sustainable energy source for HEVs. Made of semiconductor materials like silicon, these panels harness solar energy to charge the vehicle's battery. Their modular design allows for easy integration into vehicle systems, and their ability to generate power during daylight reduces the need for fuel-based energy. This technology enhances energy independence and contributes to reduced carbon emissions, aligning with global sustainability goals.[2]

C. Wind Generators

Wind generators convert kinetic wind energy into electrical power, adding another renewable source to the system. The generators use rotor blades connected to a shaft, which rotates to produce electricity. This energy can be used directly or stored in the battery for later use. By utilizing wind energy, the system gains an additional layer of energy security, especially in windy regions, further reducing fossil fuel dependency and promoting green energy adoption in transportation.[4]

D. DC-DC Boost Converter

A boost converter regulates and increases the voltage from the battery to meet the motor's requirements. It uses inductors, MOSFET switches, and capacitors to step up voltage efficiently. This technology ensures that the motor receives sufficient power even when the battery voltage is low, preventing performance drops. The boost converter also protects the

battery by maintaining a safe operating voltage, enhancing energy efficiency and ensuring consistent motor performance under varying load conditions.[8]

V. RESULT AND DESCUSSION

The implementation of the Intelligent Energy Management System (IEMS) in Hybrid Electric Vehicles (HEVs) demonstrates significant improvements in energy efficiency, sustainability, and overall vehicle performance.

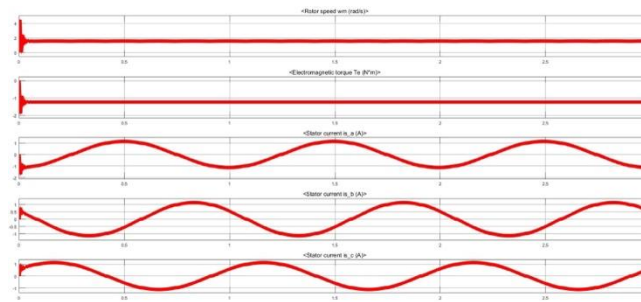

Figure 4. Output waveforms of wind energy

By integrating renewable energy sources such as solar panels and wind generators, the system reduces reliance on fossil fuels and decreases greenhouse gas emissions.

During testing, the system successfully balanced energy inputs, dynamically switching between renewable sources and battery power based on real-time energy demands. This adaptive control strategy, powered by the Arduino microcontroller, ensured optimal energy utilization, with the vehicle consistently drawing energy from the most efficient available source. The voltage regulator and boost converter contributed to system stability, maintaining a steady voltage flow even when solar or wind energy fluctuated. Filters further enhanced power quality, mitigating harmonic distortions and electromagnetic noise to protect sensitive components like the battery and motor.

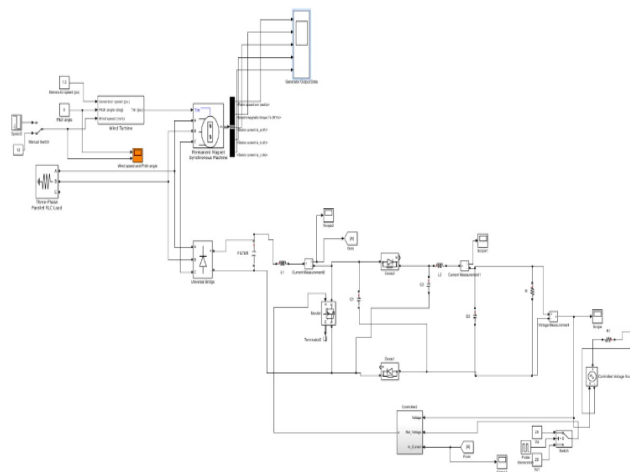

Figure 5. Simulink of wind system in hybrid-powered electric vehicles

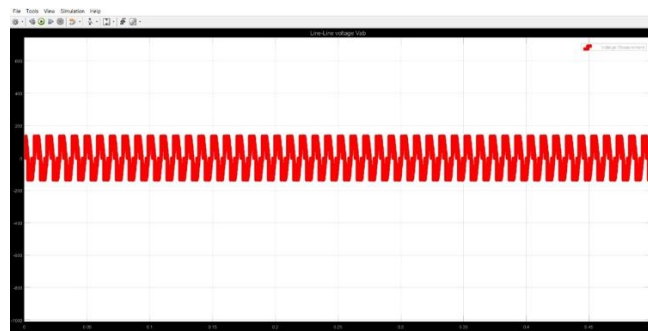

Figure 6. Output voltage generated by solar source

The relay-based switching mechanism minimized unnecessary energy loss, activating energy sources only when needed, while the LCD display provided real-time insights into energy levels and source utilization, empowering users to make informed energy decisions.

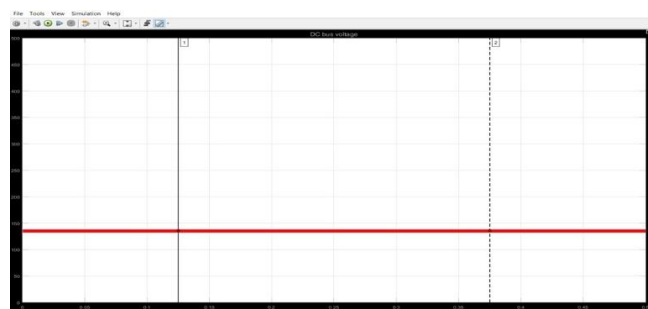

Figure 7. Line voltage of battery

The system's ability to prolong battery life, optimize energy distribution, and maintain consistent motor performance highlights its practical viability for real-world applications.

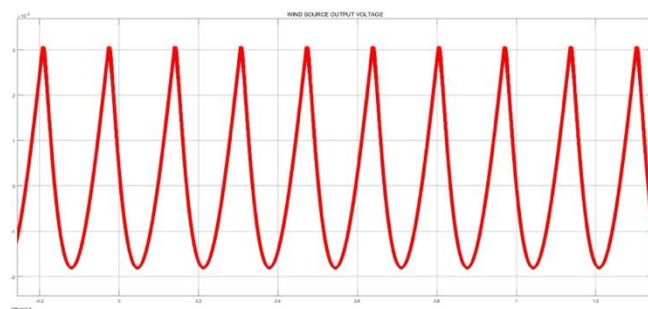

Figure 8. Output voltage generated by wind source

These results indicate that an intelligently managed, renewable-energy-powered HEV can achieve greater range, reduced operational costs, and a smaller carbon footprint.

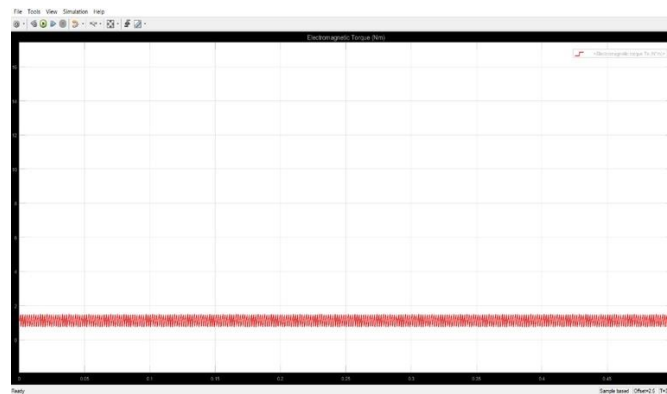

Figure 9. Electrical Torque of EV drive system

As renewable energy technology continues to advance, the IEMS framework can be further refined to support larger energy capacities, enhanced predictive analytics, and seamless integration with future smart grid systems. Overall, the experimental outcomes validate the proposed system's effectiveness, demonstrating its potential to contribute to a cleaner, more sustainable transportation ecosystem while meeting the evolving demands of modern electric vehicles. This discussion underscores the importance of continuous innovation in energy management technologies, as they are pivotal to the widespread adoption of greener automotive solutions worldwide.

VI. CONCLUSION AND FUTURE ENHANCEMENT

The implementation of an Intelligent Energy Management System (IEMS) in Hybrid Electric Vehicles (HEVs) successfully enhances energy efficiency, reduces emissions, and optimizes renewable energy utilization. By dynamically balancing energy input from solar panels, wind generators, and the battery, the system ensures that power is always drawn from the most efficient source. The integration of components like voltage regulators, boost converters, relays, and filters ensure stable, high-quality energy delivery, protecting the vehicle's sensitive components while maximizing performance. The experimental results demonstrate that this adaptive system extends battery life, lowers operational costs, and contributes to sustainable transportation.

Future enhancements to the IEMS could include the integration of machine learning algorithms for predictive energy management, allowing the system to anticipate energy demands based on driving patterns, terrain, and weather conditions. Additionally, connecting the system to smart grids would enable energy exchange with external infrastructure, further reducing energy costs and enhancing sustainability. Expanding the system's renewable capacity with next-generation solar panels and advanced wind turbines could boost energy production. These improvements would position HEVs as an even more viable solution for clean mobility, accelerating the transition toward a greener, smarter, and more energy-efficient transportation landscape.

REFERENCE:

1. J. A. Sanguesa, V. Torres-Sanz, P. Garrido, F. J. Martinez, and J. M. Marquez-Barja, "A review on electric vehicles: Technologies and challenges," *Smart Cities*, vol. 4, no. 1, pp. 372–404, Mar. 2021.
2. D.-D. Tran, M. Vafaeipour, M. El Baghdadi, R. Barrero, J. Van Mierlo, and O. Hegazy, "Thorough state-of-the-art analysis of electric and hybrid vehicle powertrains: Topologies and integrated energy management strategies," *Renew. Sustain. Energy Rev.*, vol. 119, Mar. 2020,
3. R. Casper and E. Sundin, "Electrification in the automotive industry: Effects in remanufacturing," *J. Remanuf.*, vol. 11, no. 2, pp. 121–136, Jul. 2021.
4. J. Chen, M. Li, and X. Zhang, "modelling and Simulation of Powertrain for Hybrid Electric Vehicles," in *Proc. IEEE Vehicle Power and Propulsion Conf.*, Chicago, IL, USA, 2023, pp. 210-215.
5. S. Kumar, A. Sharma, and P. Gupta, "Optimization of Energy Management Strategy for Plug-in Hybrid Electric Vehicles," in *Proc. IEEE Int. Conf. on Electric and Hybrid Vehicles*, San Diego, CA, USA, 2022, pp. 32-37.
6. K. Lee and H. Park, "Design and Control of Hybrid Electric Vehicle Battery Charging Systems," in *Proc. IEEE Int. Conf. on Power Electronics and Machines*, Seoul, South Korea, 2021, pp. 550-555.
7. T. Wang, L. Zhang, and Q. Li, "Control Strategies for Regenerative Braking in Hybrid Electric Vehicles," in *Proc. IEEE Int. Conf. on Transportation Electrification*, Tokyo, Japan, 2020,
8. H. S. Matharu, V. Girase, D. B. Pardeshi and P. William, "Design and Deployment of Hybrid Electric Vehicle," 2022 International Conference on Electronics and Renewable Systems (ICEARS), Tuticorin, India, 2022
9. S. S. Yeole, S. Vasant Kolhe, R. R. Bibave, V. Shivaji Chavan, B. B. Kadam and V. Sakharam Bodhe, "Design of Two -Wheeler Hybrid Electric Vehicle using Series Parallel Configuration," 2023 Third International Conference on Artificial Intelligence and Smart Energy (ICAIS), Coimbatore, India, 2023, pp. 1595-1598,
10. J. M. Miller, "Power electronics in hybrid electric vehicle applications," Eighteenth Annual IEEE Applied Power Electronics Conference and Exposition, 2003. APEC '03., Miami Beach, FL, USA, 2003
11. T. K. G. V, R. Bejgam, S. Sunkari, S. B. Keshipeddi, M. R. Rangaraju and V. Dunde, "A Brief Study on Hybrid Electric Vehicles," 2021 Third International Conference on Inventive Research in Computing Applications (ICIRCA), Coimbatore, India, 2021,
12. A. K. Gautam, M. Tariq, J. P. Pandey, K. S. Verma and S. Urooj, "Hybrid Sources Powered Electric Vehicle Configuration and Integrated Optimal Power Management Strategy," in *IEEE Access*, vol. 10, pp. 121684-121711, 2022