

The First Application of CO₂ Removal in a WtE Plant in Italy

Laura A. Pellegrini^a, Stefania Moioli^{a,*}, Davide Alberti^b, Adriano Carrara^{b,*}, Elena Redolfi Riva^{c,*}

^aGASP - Group on Advanced Separation Processes & GAS Processing, Dipartimento di Chimica, Materiali e Ingegneria Chimica "G. Natta", Politecnico di Milano, Piazza Leonardo da Vinci 32, 20133 Milano, Italy

^bA2A S.p.A, via Lamarmora 230 - 25124 Brescia, Italy

^cAcinque Ambiente Srl – Waste to Energy Plant, via Scalabrini 123 – 22100 Como, Italy

stefania.moioli@polimi; adriano.carrara@a2a.eu; elena.redolfi@acinque.it

The amounts of Municipal Solid Waste (MSW) produced and the greenhouse gas emissions (including CO₂) from human activities are increasing with the growing of the global population and their environmental impact needs to be reduced. Processing MSW in Waste-to-Energy (WtE) plants presents the twofold advantage of managing the MSW recovery and of producing energy, in the form of electricity and heat, avoiding the use of fossil fuels. In addition, for WtE plants operating on MSW with a significant biogenic component, Carbon Capture, Utilization and Storage (CCUS) can provide a path to negative CO₂ emissions. This research project results from a collaboration among A2A SpA, Acinque Ambiente Srl and the "Group on Advanced Separation Processes & GAS Processing" (GASP) of Politecnico di Milano and aims at installing and operating the first CCUS plant in a WtE in Italy, as part of a larger A2A SpA project for achieving the A2A SpA's decarbonization targets.

The work focuses on the section for CO₂ removal from the incinerator flue gas, performed with chemical absorption by an amine-based solvent. The design has been carried out by optimizing the main process parameters and by estimating the energy requirements considering the specificities of the flue gas to be treated, which contains about 7 mol % CO₂. Then, the considerations for choosing the appropriate size and design of the pilot plant planned to be installed in the next few years at the WtE plant in Como (Italy) are reported and discussed.

1. Introduction

Due to the high biogenic content in Municipal Solid Waste (MSW), typically within a range from 50 % to 70 % (Su et al., 2023), the adoption of Carbon Capture, Storage and Utilization (CCUS) in the Waste to Energy (WtE) sector can play a promising role in the sustainable development of urban waste management strategies and in delivering 'negative carbon emissions' for climate change mitigation. The negative carbon emissions are related to the significant bioenergy resource represented by the organic waste.

Solvent-based CO₂ absorption is one of the several technologies for removing CO₂ from the exhaust flue gases in power plants. It has been proposed for WtE plants since it is the most proven technology for CO₂ capture and no significant modifications to the original plant are required (Zanco et al., 2021). The integration in the WtE facility, as for coal-fired and Natural Gas Combined Cycle (NGCC) power plants, requires that part of steam is extracted from the power cycle for solvent regeneration, which causes an energy penalty to the WtE plant.

This work focuses on part of a research project within a collaboration among A2A SpA, Acinque Ambiente Srl and the "Group on Advanced Separation Processes & GAS Processing" (GASP) of Politecnico di Milano and aims at installing and operating the first CCUS plant in a WtE in Italy, as part of a larger A2A SpA project for achieving the A2A SpA's decarbonization targets.

The work aims at analyzing the section for CO₂ removal from the incinerator flue gas, performed with chemical absorption by an amine-based solvent. After the design, performed by optimizing the main process parameters and by estimating the energy requirements considering the specificities of the flue gas to be treated, the considerations for choosing the appropriate size of the pilot plant planned to be installed in the next few years

at the WtE plant in Como (Italy) have been carried out. In detail, two different sizes for the pilot plant have been considered, one size aimed at removing 2500 t of CO₂/y (case A) and the other one being characterized by a diameter < 0.5 m (case B), as for other plants in the literature.

2. Review on plants for CO₂ removal

According to what is reported in the literature, there is a limited number of Waste-to-Energy plants with Carbon Capture, Utilization and Storage (WtE+CCUS) in the world. The WtE+CCUS plants for which information is available are located in Saga City (Japan), Twence (Netherlands), Klemetsrud (Norway), Duiven (Netherlands) and Copenhagen (Denmark). The limited information relating to CCUS systems in WtE plants has been analyzed to better understand the size of the systems considered. The only two facilities for which the size information is available are the ones of Twence (Skylogianni et al., 2022) and of Klemetsrud (Fagerlund et al., 2021).

Over the last two decades there has been a notable increase in the installation and operation of plants, mainly pilot and demonstration, for the removal of post-combustion CO₂ through chemical absorption, though most of them being applied to flue gas from coal-fired power plant or from NGCC power plant. Some plants are characterized by a base configuration, with the absorption column and the regeneration column, and others are characterized by the addition of units for improving the process, as for instance the intercooling. A review of the size of all these plants has been carried out, with most of the pilot units being characterized by the absorption column with a diameter < 0.5 m, as the ones of SINTEF Tiller (Norway) (Knudsen et al., 2017), The University of Texas, Austin (Texas, USA) (Lin et al., 2016), CSIRO Loy Yang power station (Australia) (Bui et al., 2016), CSIRO Tarong power station (Australia) (Cousins et al., 2015) and IchPW mobile (Polonia) (Krótki et al., 2020).

3. Methodology

3.1 The considered scheme

The plant for the CO₂ removal from the WtE flue gas stream by a 30 % wt. MonoEthanolAmine (MEA) aqueous solution is assumed to be located downstream the power production plant and the treatments for the removal of the other impurities from the flue gas.

The characteristics of the flue gas emitted by the considered WtE facility are the ones considered in Moiola et al. (2024). The CO₂ content (about 7 %) is between the typical one in the flue gas exiting from a NGCC power plant and the one of a flue gas emitted from a coal-fired power plant.

The considered scheme is reported in Figure 1.

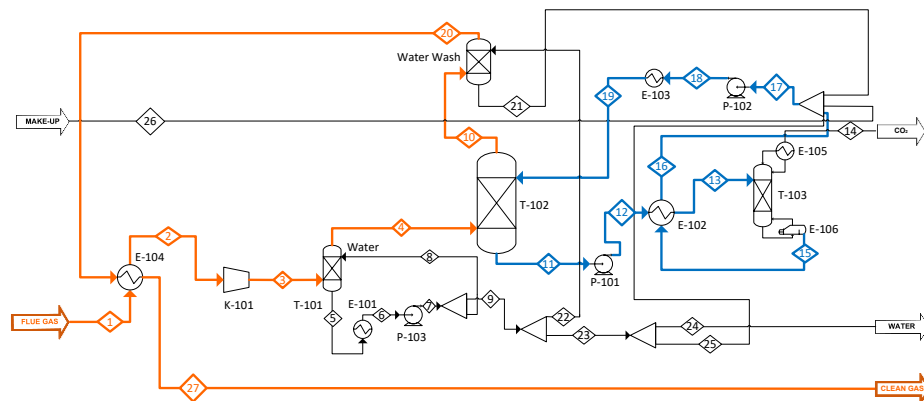

Figure 1: Scheme of the pilot plant

The gas is pre-cooled by heat exchange in the unit *E-104* with the purified gas exiting from the water-wash unit of the absorber section and, after increasing its pressure in a blower (*K-101*) in order to overcome the pressure drops in the columns and emit the clean gas at atmospheric pressure, it is further cooled in the unit *T-101*, a Direct Contact Cooler (DCC). It is, then, fed to the absorption column (*T-102*), where 90 % of the CO₂ present in the gaseous stream fed to this unit is removed, for countercurrent contact with the lean amine solvent entering from the top. The solvent exiting from the bottom of the absorber is rich in CO₂. It is pumped (*P-101*) and enters a lean-rich process-process heat exchanger (*E-102*) for heat recovery. In the regeneration column (*T-103*) the solvent is separated from the absorbed CO₂, that is recovered at the top of the unit at the exit of the partial condenser operating at 30 °C. The obtained lean solvent, after heat-exchange in the unit *E-102*, is mixed with

the MEA-rich water stream coming from the water wash section and with a make-up stream. It is further cooled in the unit *E-103* and is recycled to the absorber. In the DCC a lot of water is separated from the flue gas. It is assumed that this water is employed for the washing of the clean gas to reduce the amine emissions to the atmosphere according to Italian Regulations and for the make-up. Experimental tests on a pilot plant could confirm whether the level of impurities in water is suitable to make its utilization possible for these purposes.

3.2 Design of the pilot plant

The pilot plant has been designed on the basis of the study carried out for a full scale plant aimed at removing all the non-biogenic CO₂ emitted by the WtE plant, that amounts to 50 % of the total (Moioli et al., 2024) by rate-based simulations in ASPEN Plus® with the thermodynamic model ENRTL-RK. A 90 % CO₂ removal has been selected for sizing the units, by analogy to CO₂ removal sections in coal-fired and NGCC power plants (Moioli, 2023). The full-scale plant has been designed for minimizing both the energy consumption and the water consumption in order to limit the reduction of the net power production of the WtE plant and the water consumption. The latter is not usually considered in literature works dealing with the optimization of CO₂ removal schemes; it is taken into account in this research project due to the increased attention paid to the environmental issues related to the use and waste of high amounts of water in Italy.

The full-scale plant, sized for the removal of all the non-biogenic CO₂ present in the flue gas assumed to be the 50 % of the total, has then been scaled down (Moioli et al., 2023) for evaluating the performances of a pilot plant able to remove 2500 t of CO₂ per year (a value close to the one of Twence: 3 kt of CO₂ per year (De Vries and De Jong, 2019)), by maintaining the target of 90 % CO₂ removal for sizing the units (case A). Then, the flue gas flowrate for an absorber with a smaller diameter (about 0.4 m) has been estimated and a smaller pilot plant has been considered (case B). The analysis of the fluid dynamics of the columns for both the two sizes has been carried out to evaluate the operating range of the pilot plant.

4. Results and Discussion

4.1 Case A

4.1.1 Sizing of the plant for removing 2500 t_{CO2}/y

The main characteristics of the columns of the pilot plant for absorbing 2500 t_{CO2}/y (Moioli et al., 2023), determined as described in Section 3.2, are reported in Table 1. The flue gas flowrate is equal to 2942.79 kg/h and the solvent flowrate needed is 4949.67 kg/h.

Table 1: Main characteristics of the columns of the pilot plant sized to remove 2500 t_{CO2}/y (Case A)

	T-101	T-102	water-wash	T-103
Packing height [m]	5	16	4	10
Diameter [m]	0.55	0.55	0.4	0.28
Packing type	Norton Pall 3.5"	Mellapak 250X	Mellapak 250X	Mellapak 250X

The water wash section has been sized in this section according to the scheme reported in Figure 1, considering the addition of the make-up water to stream 16. In case of installation of the water wash section in the same column with the packing sections for the absorption of CO₂, in order to avoid the reduction of the diameter of the unit (that implies a higher installation cost and greater criticality in the construction of the unit for the pilot plant), it is possible to consider the make-up of all the water lost together with the water flow employed for the water wash, so to keep the same diameter as the absorption column for the water wash section.

4.1.2 Analysis of the fluid dynamics

The analysis of the fluid dynamics of the columns for the pilot plant with an absorption column diameter equal to 0.55 m has been carried out in order to determine the operating range of flue gas flowrate without critical issues in fluid dynamics and the related energy consumptions.

The plant sized to remove 2500 t_{CO2}/year can operate, without critical issues in fluid dynamics, in a flue gas flowrate range between -8 % and +4 % compared to the base case flowrate. The lean solvent flowrate varies to achieve 90 % CO₂ removal in all the cases.

For -38 % ≤ flue gas flowrate ≤ -9 % and for 5 % ≤ flue gas flowrate ≤ 18 %, the absorption column can operate without fluid dynamic issues, that are found in the DCC and in the regeneration column. For flue gas flowrates < -38 % and for flue gas flowrates > 18 %, fluid dynamic issues are also found for the absorption column.

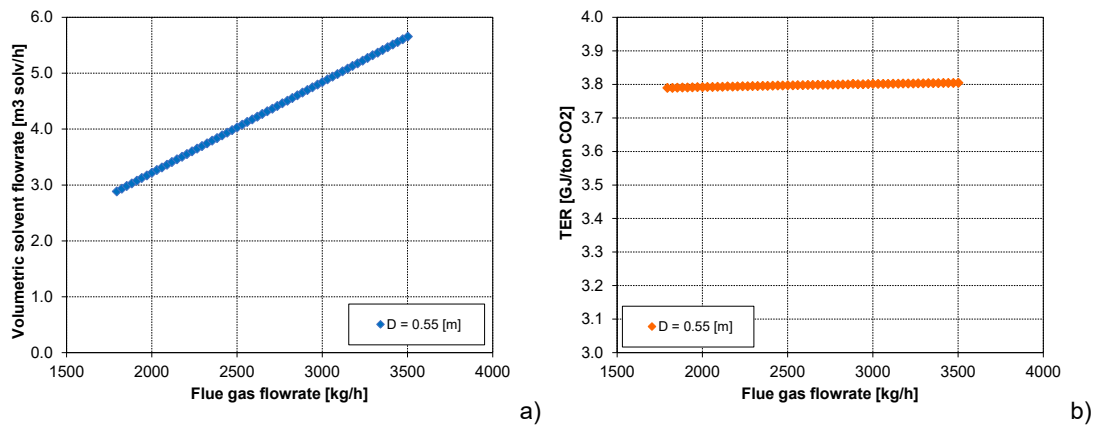

Figure 2: a) lean solvent flowrate and b) Thermal Energy Requirement (TER) by varying the flue gas flowrate to the pilot plant

Maintaining the same dimensions of the pilot plant, for the same percentage of CO₂ removal the required solvent flowrate increases as the flue gas flowrate increases (Figure 2a)). A greater amount (mass flowrate) of CO₂ is removed with a proportional greater amount of solvent and the TER (Thermal Energy Requirement), expressed per unit of CO₂ removed (Figure 2b)), does not vary.

The steam consumption (estimated) increases as the flowrate of the flue gas increases (Figure 3a)), due to the greater amount (mass flowrate) of CO₂ removed. The amount of steam has been estimated by assuming steam from 5.5 bar and 160 °C to 4.5 bar and 130 °C. In this paper, no pressure drops for the instrumentation before the Kettle reboiler that change the steam conditions from 5.5 bar and 160 °C have been considered. For the Kettle reboiler the use of steam has been assumed, for a pilot plant a different hot source (diathermic oil, etc.) could also be taken into account.

The total duty needed for cooling (Figure 3b)), by keeping all other conditions equal, is influenced by the duties required by the condenser of the regeneration column and by the other two heat exchangers, that increase as the flowrate of treated flue gas increases.

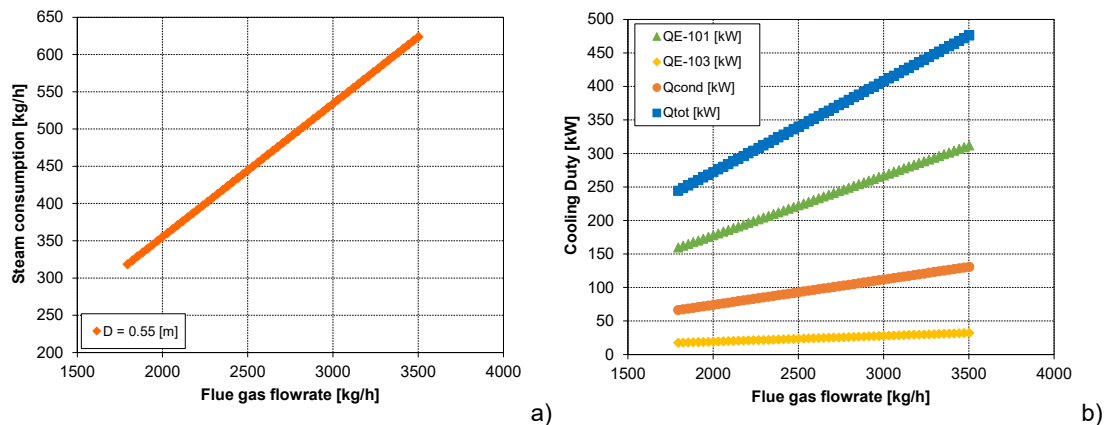

Figure 3: a) steam consumption and b) cooling duty by varying the flue gas flowrate to the pilot plant

4.2 Case B

4.2.1 Absorption column with a diameter of ~ 0.40 m

In order to reduce the energy consumptions, on the basis of information related to other post-combustion CO₂ removal systems (Section 2), the performance of a pilot plant with an absorption column with a diameter of approximately 0.40 m has been analysed. A nominal diameter of 16", that corresponds to an external diameter equal to 406.40 mm, with a thickness equal to 6.35 mm (SCH 10), has been considered (the final choice of the thickness is to be considered before the construction of the plant, the thickness corresponding to schedule 10 may be too thin). The internal diameter of the column is equal to 393.70 mm.

The optimal flue gas flowrate has been determined on the fluid dynamics of the absorption column (Figure 4 reports the estimated diameter as a function of the flue gas flowrate). Then, the other units of the pilot plant have been sized for the determined flowrate, considering 90 % of CO₂ removed, and the energy consumption has been determined. The diameter of all the columns is reported in Table 2. The optimal flowrate of the flue gas for an absorption column with an internal diameter of 0.3937 m is equal to 1471.40 kg/h, with a reduction of 50 % compared to the case with an internal diameter (ID) of the column equal to 0.55 m.

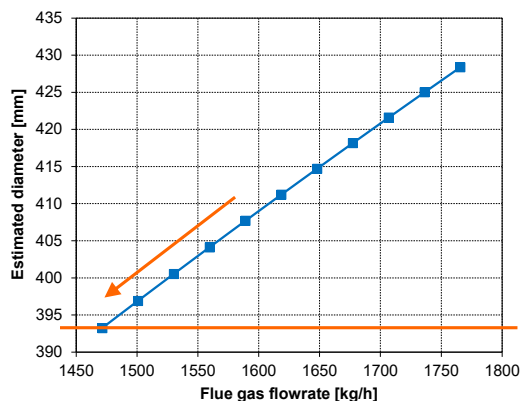

Figure 4: Estimated diameter by varying the flue gas flowrate

Table 2: Main characteristics of the columns of the pilot plant sized considering a flue gas flowrate equal to 1471.40 kg/h

	T-101	T-102	water-wash	T-103
Packing height [m]	5	16	4	10
Diameter [m]	0.3937	0.3937	0.28	0.21
Packing type	Norton Pall 3.5"	Mellapak 250X	Mellapak 250X	Mellapak 250X

4.2.2 Analysis of the fluid dynamics

The pilot plant with the absorption column with a diameter of ~ 0.40 m can operate, without critical issues in the fluid dynamics, in range of flue gas flowrate between -1 % and +5 % compared to the base case flowrate. The lean solvent flowrate varies to achieve 90 % CO₂ removal in all the cases. For -38 % ≤ flue gas flowrate ≤ -2 % and for 6 % ≤ flue gas flowrate ≤ 16 %, the absorption column can operate without fluid dynamic issues, that occur in the DCC and in the regeneration column. For flue gas flowrates < -38 % and for flue gas flowrates > 16%, fluid dynamic issues are also found for the absorption column.

4.3 Comparison between the two sizes of the pilot plant

The energy requirements of the pilot plant for the two considered sizes have been evaluated and compared (Table 3 and Table 4). In the case of feeding 1471.40 kg/h of flue gas to the absorption column (for a diameter of the absorber of about 0.40 m), the energy requirements are much lower and correspond to about 50 % of the ones for the pilot plant of larger size.

The smaller size (Case B) is in line with some of the most used pilot plant for CO₂ removal reported in the literature and can be chosen as size of the experimental plant to be built for testing the technology on the flue gas of the WtE plant of Como (Italy), the first one of this type in this country.

Table 3: Consumption of the electric power for the main units of the process for CO₂ removal for the two different sizes of the pilot plant

	K-101 [kW]	P-101 [kW]	P-102 [kW]	P-103 [kW]
ID of the absorption column = 0.55 m	37.26	0.32	0.13	0.23
ID of the absorption column ~ 0.40 m	18.63	0.16	0.06	0.12

Table 4: Consumption of the thermal duty for cooling (negative) or for heating (positive) for the main units of the process for CO₂ removal for the two different sizes of the pilot plant

	E-101 [kW]	E-103 [kW]	Condenser (E-105) [kW]	Reboiler (E-106) [kW]
ID of the absorption column = 0.55 m	-262.55	-27.76	-110.08	+321.87
ID of the absorption column ~ 0.40 m	-131.29	-13.13	-54.56	+160.24

5. Conclusions

This work focused on the definition of the size of the first pilot plant applied to the removal of CO₂ from the WtE flue gases, to be built at the WtE plant in Como (Italy). The operating flowrate range of flue gas and the related energy consumption have been firstly evaluated for the pilot plant with an internal diameter of the absorption column equal to 0.55 m (Case A). Then, the absorption column of the pilot plant with a lower diameter, ~ 0.40 m (Case B), has been considered and the flowrate of the flue gas to be fed has been determined, the sizing of the other columns and the evaluation of the energy consumption of the plant have been carried out and the operating range of flue gas flowrate and the related energy consumption have been evaluated. A comparison between the two sizes has been carried out. On the basis of the obtained results, the size of the pilot plant to be built has been defined to be the smaller one (Case B), with a diameter of the absorption column equal to approximately 0.40 m, to treat a flowrate of flue gas equal to 1471.40 kg/h.

References

- Bui M., Gunawan I., Verheyen V., Feron P., Meuleman E., 2016, Flexible operation of CSIRO's post-combustion CO₂ capture pilot plant at the AGL Loy Yang power station, *International Journal of Greenhouse Gas Control* 48, 188-203.
- Cousins A., Huang S., Cottrell A., Feron P.H.M., Chen E., Rochelle G.T., 2015, Pilot-scale parametric evaluation of concentrated piperazine for CO₂ capture at an Australian coal-fired power station, *Greenhouse Gases: Science and Technology* 5, 7-16.
- De Vries R., De Jong W., 2019, CCU at Twence Status from Pilot to Demonstration, Workshop on EU funding opportunities for CCU projects, Brussels, Luxembourg.
- Fagerlund J., Zevenhoven R., Thomassen J., Tednes M., Abdollahi F., Thomas L., Nielsen C.J., Mikoviny T., Wisthaler A., Zhu L., Biliyok C., Zhurkin A., 2021, Performance of an amine-based CO₂ capture pilot plant at the Fortum Oslo Varme Waste to Energy plant in Oslo, Norway, *International Journal of Greenhouse Gas Control* 106, 103242.
- Knudsen J.N., Wærnes O., Svendsen H.F., Graff O., 2017, Highlights and Main Findings from the 8 Year SOLVIT R&D Programme – Bringing Solvents and Technology from Laboratory to Industry, *Energy Procedia* 114, 5701-5710.
- Krótki A., Więclaw Solny L., Stec M., Spietz T., Wilk A., Chwoła T., Jastrzab K., 2020, Experimental results of advanced technological modifications for a CO₂ capture process using amine scrubbing, *International Journal of Greenhouse Gas Control* 96, 103014.
- Lin Y.-J., Chen E., Rochelle G.T., 2016, Pilot plant test of the advanced flash stripper for CO₂ capture, *Faraday Discussions* 192, 37-58.
- Moioli S., 2023, Design of the process of CO₂ removal in NGCC by potassium taurate solvent, *Chemical Engineering Research and Design* 195, 96-105.
- Moioli S., De Guido G., Pellegrini L.A., Fasola E., Alberti D., Carrara A., 2023, Case Study for the Application of CCUS to a Waste-to-Energy Italian Plant, 9th International Acid Gas Injection, CCS, CCUS, CO₂ EOR Symposium (AGIS IX), Calgary, Alberta.
- Moioli S., De Guido G., Pellegrini L.A., Fasola E., Riva E.R., Alberti D., Carrara A., 2024, Techno-economic assessment of the CO₂ value chain with CCUS applied to a waste-to-energy Italian plant, *Chemical Engineering Science* 287, 119717.
- Skylogianni E., Veronezi Figueiredo R., van Os P., Frost J., Hall J., Yelland T.S., Kiewik J., Vos M., Garcia Moretz-Sohn Monteiro J., 2022, Demonstration of Solvent Performance at an Industrial WtE Facility, 16th Greenhouse Gas Control Technologies Conference (GHGT-16), Lyon, France.
- Su D., Herraiz L., Lucquiaud M., Thomson C., Chalmers H., 2023, Thermal integration of waste to energy plants with Post-combustion CO₂ capture, *Fuel* 332, 126004.
- Zanco S.E., Pérez-Calvo J.-F., Gasós A., Cordiano B., Becattini V., Mazzotti M., 2021, Postcombustion CO₂ Capture: A Comparative Techno-Economic Assessment of Three Technologies Using a Solvent, an Adsorbent, and a Membrane, *ACS Engineering Au* 1, 50-72.