

Design of a Liquid Hydrogen Export Terminal for Green Hydrogen Transport: a Mediterranean Case Study

Federica Restelli^{a,*}, Laura A. Pellegrini^a, Saif Z.S. Al Ghafri^b, Fuyu Jiao^b, Michael Johns^b, Eric F. May^b

^aGASP - Group on Advanced Separation Processes & GAS Processing, Dipartimento di Chimica, Materiali e Ingegneria Chimica "G. Natta", Politecnico di Milano, Piazza Leonardo da Vinci 32, 20133 Milano, Italy

^bFluid Science and Resources Division, Department of Chemical Engineering, Faculty of Engineering and Mathematical Sciences, The University of Western Australia, Crawley, WA 6009, Australia
federica.restelli@polimi.it

Implementing hydrogen supply chains using liquid hydrogen (LH₂) as a carrier presents significant challenges, among which the design of export terminals due to the boil-off gas (BOG) generation associated with the storage and handling of a cryogenic fluid. This study investigates BOG management at an export terminal through dynamic simulations conducted with Aspen HYSYS[®] V12.1. The terminal, operating with a LH₂ production rate of 44,000 kg/d, is designed to transport green hydrogen from North Africa to Northern Italy over a harbour-to-harbour distance of 2,500 km. The operational cycle, which includes storage tank filling and LH₂ carrier loading, spans approximately 10 days, with all generated BOG potentially recoverable through reliquefaction or high-pressure storage. The levelized cost of hydrogen for terminal storage and shipment is estimated at 3.09 €/kg, highlighting the necessity for further research to reduce costs and enable the economic feasibility of LH₂ supply chain.

1. Introduction

Hydrogen, a high-capacity energy carrier, can be produced by electrolyzing water using electricity derived from renewable sources. However, the most economically competitive renewable energy hubs are often located thousands of kilometers from major industrial sites in Europe. This creates a need for storage and supply chain infrastructures to transport hydrogen over long distances. For seaborne hydrogen transport, liquid hydrogen (LH₂) stands out as a promising option, given that its mass density is roughly 800 times greater than gaseous hydrogen under standard conditions (Al Ghafri et al., 2022). While much of the literature focuses on designing the hydrogen liquefaction process, relatively few studies address the design of the necessary export infrastructure. This infrastructure faces significant technical challenges, primarily due to the extremely low temperature of liquid hydrogen, which is 20 K at atmospheric pressure. Managing such low temperatures requires materials that maintain strength under these conditions and high-performance insulation to minimize heat transfer. Another critical issue is boil-off gas (BOG) generation during liquefied hydrogen storage and transfer to the ship (Kim et al., 2022). This occurs due to flashing caused by depressurization, vapor displacement, heat leak from the environment and heat introduced by equipment like pumps.

The infrastructure for store and transporting liquid hydrogen shares similarities with that of liquefied natural gas (LNG), as both require cryogenic conditions. However, LH₂ requires more advanced insulation due to its significantly lower boiling temperature at atmospheric pressure, and lower volumetric energy density. Large volumes of LH₂ are typically stored in spherical tanks due to their minimal surface-to-volume ratio. These tanks are designed with double walls. The inner vessel walls are usually made from 300-series stainless-steel alloys, while the outer vacuum shells are constructed from carbon steel. The space between the double walls serves as an insulation layer, filled with materials such as perlite or glass bubbles and maintained under vacuum conditions. This design achieves thermal conductivities in the order of 10⁻³ to 10⁻⁴ W/(m·K) (Fesmire et al., 2022). In 2019, NASA began constructing a 4,700 m³ LH₂ storage tank to support the Artemis program. It is designed

to operate at a maximum pressure of 6.2 barg and utilizes vacuum glass bubble technology for insulation (Fesmire et al., 2022). In 2020, a 2,250 m³ LH₂ storage tank was constructed in Japan as part of the world's first LH₂ terminal in Kobe, designed to receive LH₂ shipped from Australia. Kawasaki Heavy Industries developed the Suiso Frontier, the first dedicated LH₂ carrier. This vessel, operational since 2021, features a 1250 m³ type-C tank, which is a pressure vessel, and transports LH₂ between Australia and Japan (HESC). Vacuum-insulated pipelines are employed to minimize heat transfer to cryogenic fluids. These pipelines feature two concentric pipes: the inner pipe transports the LH₂, while the outer pipe offers structural support. The space between the pipes is evacuated to suppress conductive and convective heat transfer. To reduce radiative heat transfer, insulating systems like multi-layer insulation or perlite are often applied within this space. The thermal conductivities of these insulation technologies range from 0.006 to 0.0008 W/(m·K) (Śliwa et al., 2018). Submersible LH₂ loading pumps are installed inside storage tanks to mitigate the risk of leakage. Given the technical challenges associated with the BOG management during LH₂ storage and transport, this work aims at designing a LH₂ export terminal and analyzing BOG generation through dynamic simulations of storage and carrier loading. Indeed, understanding the time-dependent BOG generation rate is crucial for identifying possible BOG recovery strategies. To investigate this, a case study is considered, which involves the transport of hydrogen, produced by 100 MW electrolyzers powered by renewable electricity, from North Africa to Northern Italy (Restelli et al., 2024). The analysis evaluates the plant's energy consumption and the rate of boil-off gas, which requires additional energy for reliquefaction. Combined with studies on the energy consumption of the liquefaction process, this work helps identifying the total energy requirements and associated costs of exporting renewable energy via liquid hydrogen.

2. Case study description

The LH₂ export terminal analysed in this study is designed to support the delivery of green hydrogen from a hypothetical renewable electricity hub situated in North Africa to a hypothetical utilization site in Northern Italy. The transport route spans a sea distance of approximately 2,500 km. The green hydrogen is supposed to be produced by a 100 MW electrolyser and sent to a liquefaction plant with a constant flow rate F of 44,000 kg/d. The resulting liquid hydrogen at a pressure of 4 bar and a temperature of 25 K constitutes the feed to the considered export terminal. The considered LH₂ export terminal comprises harbour storage, loading pipelines, LH₂ carrier, and boil-off gas compressors. The capacity of the LH₂ carrier is determined based on the quantity of liquefied hydrogen produced and stored at the terminal during the period when the carrier is not docked, denoted with τ , which is about 10 days, as estimated by Restelli et al. (2024) for a similar LH₂ export case study. The carrier's gross capacity, V_{offshore} , is calculated using Eq(1). This calculation considers a maximum fill level of 98 % of the vessel's volume as safety constraint, and a 4 % heel remaining in the tank for cooling purposes, consistent with industrial practices for LNG tanks (Rogers, 2018). In Eq(1), ρ is the LH₂ mass density at the storage conditions.

$$V_{\text{offshore}} = \frac{F \cdot \tau [\text{d}]}{\rho [\text{kg}/\text{m}^3] \cdot (0.98 - 0.04)} = \frac{44,000 [\text{kg}/\text{d}] \cdot 10 [\text{d}]}{66 [\text{kg}/\text{m}^3] \cdot (0.98 - 0.04)} = 7,100 [\text{m}^3] \quad (1)$$

The storage capacity at the export terminal, V_{onshore} , is determined by increasing the carrier's transported volume by 25 % as a safety margin to account for potential delays (Eq(2)).

$$V_{\text{onshore}} = V_{\text{offshore}} \cdot (1 + 0.25) = 8,900 [\text{m}^3] \quad (2)$$

Liquid hydrogen from the liquefaction plant is loaded into the onshore tank while awaiting the ship's arrival. Once the storage tank is fully filled, LH₂ is loaded from the onshore tank into the LH₂ carrier's tank through two pipelines, assumed to have a length of 500 m. During loading, the BOG generated in the ship's tank is compressed slightly and sent back to the onshore storage tank via a separated pipeline in order to maintain its operating pressure. Both the onshore and offshore tanks are designed to operate at 2.5 bar, with a maximum allowable pressure of 7 bar and a minimum pressure of 1.03 bar (ambient pressure). Each tank is equipped with a boil-off gas compressor and a relief valve to control the pressure. The relief valve is used only in extreme cases where the tank's pressure exceeds the maximum limit. The onshore compressor removes the BOG redirecting it to a recovery system, likely designed for reliquefaction. The maximum flow rate during loading operations is assumed to be 2,000 m³/h. A maximum fluid velocity of 4 m/s in pipelines is adopted, consistent with LNG practices, although higher velocities could be feasible due to the lower pressure drop per unit length of LH₂ compared to LNG, resulting from its lower mass density. Consequently, pipelines with a nominal diameter of 300 mm are selected.

3. Dynamic simulation of the export terminal

As boil-off gas generation during liquid hydrogen storage and carrier loading operations varies over time, a dynamic simulation is required for its analysis. Aspen HYSYS® V12.1 is employed as the process simulator, utilising the Modified Benedict-Webb-Rubin (MBWR) thermodynamic package to calculate hydrogen properties. The only modelled component is para-hydrogen, as the conversion from normal-hydrogen to para-hydrogen is assumed to be completed during the liquefaction process. A base ambient temperature of 298.15 K is considered. A process scheme of the plant is shown in Figure 1.

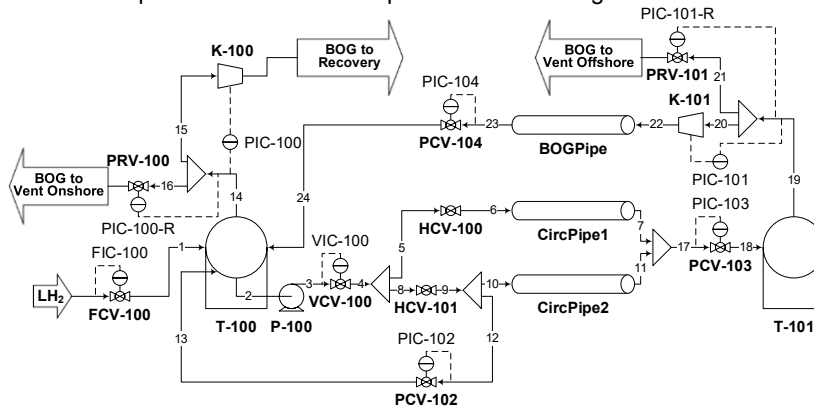

Figure 1: Process scheme of the LH₂ export terminal.

The simulation assumes that the onshore storage tank remains partially filled with cold liquid hydrogen from its initial filling until the plant shuts down. The onshore storage tank's initial liquid volume percentage is set to 15 %. Similarly, the offshore storage tank (located on the carrier) retains a small amount of cargo after unloading, in line with standard LNG practices. The initial liquid volume in the offshore storage tank is set to 4 %. To simulate the cyclic operations of the export terminal, which include storage tank filling and carrier loading, two operational modes are defined:

- Holding mode: the onshore storage tank (T-100 in Figure 1) is at LH₂ temperature and partially filled with liquid hydrogen. The loading lines are also kept at LH₂ temperature and filled with circulating LH₂ at a low flow rate from the onshore tank. T-100 continues to fill until its liquid volume percentage reaches 90 %.
- Loading mode: the offshore storage tank (T-101 in Figure 1) is at LH₂ temperature and partially filled with liquid hydrogen. LH₂ is pumped from the onshore tank to the offshore tank at a high flow rate until the offshore tank's liquid volume reaches 98 %. By this stage, the loading lines are already pre-cooled.

The inlet stream (LH₂) has a mass flow rate 44 t/d (controlled by FCV-100 and FIC-100), a pressure of 4 bar, and a temperature of 25 K, according to the basis of design for the considered case study (see Section 2). The discharge of the onshore BOG compressor is set to 7 bar. The pressure of the outlet streams destined for other uses or disposal, BOG To Vent Onshore and BOG To Vent Offshore, is set to 1.03 bar. The onshore (T-100) and offshore (T-101) storage tanks are both spherical. A detailed heat transfer model is implemented for the tanks, accounting for natural convection inside and outside the tank, as well as conduction through the metal wall and insulation layers. The inner tank, having a thickness of 0.018 m, is constructed from stainless steel, which is characterized by a specific heat capacity, c_p , of 0.51 kJ/(kg·K), a mass density, ρ , of 7930 kg/m³ and a thermal conductivity, k , of 150 W/(m·K). The outer insulation employs vacuum glass bubble technology, featuring a thickness of 1.403 m, and k of 0.0007 W/(m·K). The overall heat transfer coefficient is dynamically updated during integration, reflecting changes in the temperature profile. P-100 is the pump system installed inside the onshore tank. This system comprises four pumps, each with a capacity of 500 m³/h, to manage the loading flow rate, and a single pump with a capacity of 10 m³/h, to handle the lower circulation flow rate during holding mode. At the beginning and end of the loading mode, flow rate ramp-up and ramp-down are executed in increments of 500 m³/h every 15 minutes, allowing the operation to be completed within one hour, consistent with current LNG practices. This is achieved by sequentially engaging or disengaging one pump per onshore tank at each step. The pumps are designed with an overall efficiency of 75 %, incorporating both isentropic and electrical/mechanical efficiencies. They provide a pressure increase of 2 bar to ensure adequate driving force for carrier loading. The pipelines, CircPipe1, CircPipe2 and BOGPipe, connecting the onshore and offshore storage tanks have a length of 500 m. Their diameters are determined to comply with maximum velocity limits: 4 m/s for liquid flow and 20 m/s for vapor flow. Inner and outer diameters are chosen based on industrial standards for stainless steel pipelines (Schedule 5S). The pipelines utilize vacuum multi-layer insulation technology, featuring an insulation thickness of 0.050 m and a k of 0.001 W/(m·K). The overall heat transfer

coefficient is dynamically updated during integration. Pressure drop calculations are conducted using the Beggs and Brill correlation (Payne et al., 1979), with pipeline roughness set at $4.572 \cdot 10^{-5}$ m, as recommended by Aspen HYSYS® for mild steel. K-100 and K-101 are BOG compressors designed to function at exceptionally low suction temperatures, around 25 K. Due to uncertainties regarding the performance of compressors under such conditions, an isentropic efficiency of 50 % is assumed. These compressors regulate tank pressure by varying their rotational speed. The capacity of each unit is sized to accommodate the average BOG flow rate they are required to manage. The feed flow rate is managed by controller FIC-100, which adjusts the actuator position of flow control valve FCV-100. The set point (SP) corresponds to the LH₂ flow rate from the liquefaction process. Pressure in the onshore tank is regulated by a combination of compressor K-100 and relief valve PRV-100. The controller PIC-100 modifies the compressor's speed to maintain the onshore tank header pressure at the SP of 2.5 bar. The valve, normally closed, opens when the tank pressure exceeds 7 bar, the maximum operating pressure. This condition may occur during initial tank cooling or unexpected changes in the process that lead to high BOG generation. Similarly, the offshore tank pressure is controlled by compressor K-101 and relief valve PRV-101. The volumetric flow control valve VCV-100 regulates the flow rate in the pipelines, with a SP of 10 m³/h during holding mode and 2,000 m³/h during loading mode. The pressure within the LH₂ pipelines is maintained at 4.25 bar for both holding and loading modes. Pressure control is achieved using PCV-102 during holding mode and PCV-103 during loading mode. In holding mode, PCV-103 and HCV-101 remain closed, allowing LH₂ to flow from the onshore tank through CircPipe1, then CircPipe2, and back to the onshore tank. In loading mode, PCV-102 is closed, while HCV-101 and PCV-103 are opened, enabling LH₂ to flow from the onshore tank through CircPipe1 and CircPipe2 in parallel to the offshore tank. The pressure in the BOG return pipeline is controlled at 4 bar by PCV-104.

4. Economic assessment methodology

The Levelized Cost Of Hydrogen (LCOH), as defined by Restelli et al. (2024), is used as the metric for economic assessment. This indicator depends on the capital expenditures (CAPEX), operating expenditures (OPEX), flow rate of hydrogen delivered, plant lifetime, assumed to be 25 y, and interest rate, assumed equal to 5%. The reference year of the estimate is 2023. The amount of LH₂ delivered is calculated considering that the ship utilizes hydrogen gas as a fuel and that the heel is 4 %. Gaseous hydrogen is produced either by warming BOG generated during shipping or, if necessary, by evaporating and warming LH₂ from the cargo. The BOG rate during maritime transport is assumed to be 0.2 %/d, while the fuel consumption rate is estimated at 2,160 kg/d, based on the power requirements of an LNG carrier of comparable size (Damen, 2017), considering hydrogen's lower heating value of 33.3 kWh/kg. The investment cost methodology implemented in this study is based on equipment purchase cost functions and percentage cost factors to account for installation (Walas, 1998). Cost-capacity relationships are derived from the work of Restelli et al. (2025). Spare units for pumps and compressors are included in the analysis. The bare module cost is estimated using an equipment installation factor ($f_{ins,eq}$) that varies depending on equipment type and complexity, with data sourced from literature (Nexant Inc., 2008). Additionally, a general installation factor (f_{ins}) is applied to cover costs related to engineering and supervision, overhead, administration, construction, general electrical and safety systems, site preparation, offsite capital, contracting fees, project execution, and commissioning. This factor, typically expressed as a multiplier of the total equipment cost (Walas, 1998), is set to $f_{ins} = 1.6$ in line with recent findings by Lee et al. (2022). OPEX includes utility costs related to the electricity consumption by pumps and compressors, which is retrieved from the simulation. The price of electricity is estimated to be 0.032 €/kWh, with electricity prices estimated at 0.032 €/kWh based on Algeria's average electricity price in 2023 (Statista, 2023). Operating and maintenance expenses are assumed to be 10 % of the annual CAPEX.

5. Results and discussion

Table 1 presents the results for the duration and BOG generation for each operational mode and the overall process. The holding mode lasts 257.3 h (10.7 d), while the loading mode takes 4.7 h. It is important to note that during export terminal operations, no BOG is vented. The BOG reported in Table 1 refers to the amount processed by compressor K-100 and sent to a recovery unit, as detailed in Section 5.2. During the export terminal operations, the total BOG generation accounts for 10.1 % of the total LH₂ feed.

Table 1: Case study results for each operational mode and the overall process.

Mode	Duration [h]	Total BOG [t]	Average BOG flow rate [t/d]	BOG% of the feed [%]
Holding (I)	257.3	47.8	4.5	10.1
Loading (II)	4.7	0.7	3.6	8.3
Overall (I+II)	262.0	48.5	4.4	10.1

Figure 2 shows the simulation strip charts for the examined case study, in terms of tanks' pressure (Figure 2a) and BOG mass flow rate (Figure 2b). The onshore tank pressure fluctuates between 2.44 and 2.71 bar. The minimum pressure occurs at the end of the holding mode, coinciding with the lowest BOG generation rate. Conversely, the maximum pressure is observed at the end of the loading mode, attributed to the combined BOG generated from the liquid stored in the tank and the BOG received from the offshore tank. This BOG compensates for the liquid displaced during loading. However, during flow rate ramp-down operation at the end of the loading mode, the displaced liquid volume decreases while the injection of BOG from the offshore tank remains significant, contributing to the pressure increase. The offshore tank pressure ranges from 2.50 to 2.77 bar. It gradually increases during the offshore tank's filling phase (loading mode) and slightly decreases during the flow rate ramp-down, as the vapor displacement in the offshore tank lessens, reducing pressure build-up.

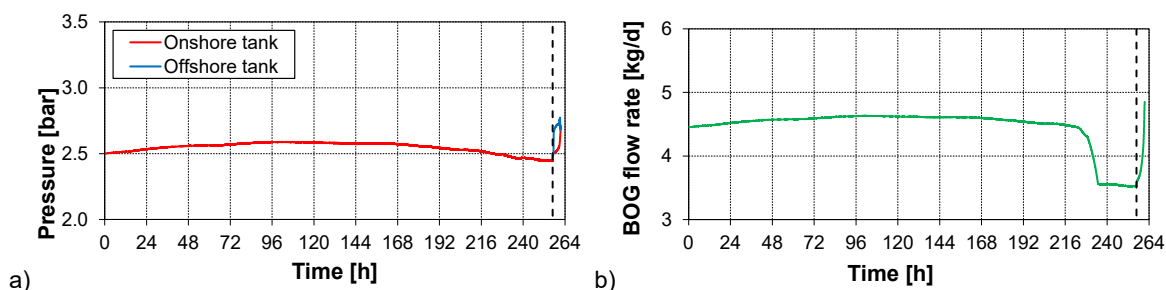

Figure 2: Strip charts of the case study: a) Onshore and offshore storage tank pressure, and b) BOG to liquefaction mass flow rate, as functions of time. The vertical dashed line indicates the transition between operational modes.

5.1 BOG recovery strategies

Wasting hydrogen boil-off gas through venting or flaring leads to substantial energy losses, as hydrogen production and liquefaction are energy-intensive and costly. With an almost constant BOG flow rate (green line in Figure 2b) of about 4,453 kg/day, the most practical solution is to reliquefy the BOG, either by utilizing the main liquefaction plant or by employing a dedicated small-scale reliquefaction system. One key advantage of this approach is that the hydrogen gas does not require precooling, as it is already at cryogenic temperatures. Emerging technologies, such as magnetocaloric materials, offer innovative solutions for BOG reliquefaction. These materials utilize the magnetocaloric effect, where the application and removal of a magnetic field cause a material to alternately heat and cool. This method is particularly suitable for small-scale operations, offering highly efficient and compact cooling systems that reduce the energy demands of conventional cryogenic refrigeration (Numazawa et al., 2014). Alternative BOG recovery strategies include compressing and storing the hydrogen gas at high pressure in specialized cylindrical tanks. The stored gas can then be sold as compressed hydrogen or used on-site, such as for power generation. Additionally, advanced storage technologies like metal-organic frameworks (MOFs) and adsorption-based systems are under development. These systems show promise due to their high hydrogen uptake at low temperatures and moderate pressures, offering innovative pathways for efficient BOG management (Shet et al., 2021).

5.2 Economic assessment

The total CAPEX for the investigated LH₂ export case study is estimated to 205.9 M€, with the largest expense attributed to the onshore storage tanks and the ship, as illustrated in the pie chart in Figure 3. The OPEX is projected at 20.6 M€/y, with minimal contributions from the electricity consumption of loading pumps and BOG compressors (0.004 M€/y). The main OPEX driver is the cost of operations and maintenance (20.6 M€/y). The resulting LCOH for storage and maritime transport is 3.09 €/kg. When combined with the costs of hydrogen production and liquefaction, the high LCOH highlights the critical need for cost reductions across the entire supply chain to establish LH₂ as a competitive energy carrier.

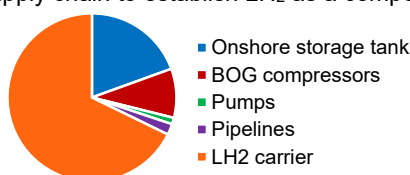

Figure 3: Breakdown of the total bare module cost by contributions from various equipment.

6. Conclusions

This work study explores the operation of a hypothetical liquid hydrogen export terminal. For the case study examined, involving a liquid hydrogen feed flow rate of 44,000 kg/d, and a harbour-to-harbour distance of 2,500 km, the cyclic operation at the export terminal is repeated about 30 times a year. The generated boil-off gas, which maintains a nearly constant flow rate throughout the cycle, can be recovered by reliquefying it at a nearby liquefaction plant, which operates continuously. The levelized cost of hydrogen for terminal storage and shipment is calculated at 3.09 €/kg, emphasizing the need for further research to reduce costs for liquid hydrogen export to become economically feasible. This study marks an initial step toward assessing the potential of liquefied hydrogen as a means to transport green hydrogen across the Mediterranean Sea.

Nomenclature

c_p – specific isobaric heat capacity, kJ/(kg·K)
 F – mass flow rate, kg/d

ρ – mass density, kg/m³
 k – thermal conductivity, W/(m·K)

Acknowledgments

The work has been supported by the Future Energy Exports CRC (www.fenex.org.au) whose activities are funded by the Australian Government's Cooperative Research Centre Program.

References

- Al Ghafri S.Z.S., Munro S., Cardella U., Funke T., Notardonato W., Trusler J.P.M., Leachman J., Span R., Kamiya S., Pearce G., Swanger A., Rodriguez E.D., Bajada P., Jiao F., Peng K., Siahvashi A., Johns M.L., May E.F., 2022, Hydrogen liquefaction: a review of the fundamental physics, engineering practice and future opportunities, *Energy & Environmental Science*, 15, 2690-2713.
- Damen, 2017, products.damen.com/-/media/products/images/clusters-groups/shipping/liquefied-gas-carrier/liquefied-gas-carrier-7500-Ing/downloads/product_sheet_damen_liquefied_gas_carrier_7500_Ing_10_2017.pdf?rev=7e8230a833e1458ca06c29a4b7a6b5e4 (accessed 24 January 2023).
- Fesmire J., Swanger A., Jacobson J., Notardonato W., 2022, Energy efficient large-scale storage of liquid hydrogen, *IOP Conference Series: Materials Science and Engineering* 1240, 012088.
- Hydrogen Energy Supply Chain (HESC), www.hydrogenenergysupplychain.com/about-the-pilot/supply-chain/the-suiso-frontier (accessed 17 October 2024).
- Kim J., Vu H.T.T., Kim S., Choi M., Lee E., Park K., Kim J., Park H., Choi B., Han J., Kim H., Choi J., Chang D., 2024, Technical feasibility of large-scale transportable liquid hydrogen export terminal. *International Journal of Hydrogen Energy* 66, 499-511.
- Lee J.-S., Cherif A., Yoon H.-J., Seo S.-K., Bae J.-E., Shin H.-J., Lee C., Kwon H., Lee C.-J., 2022, Large-scale overseas transportation of hydrogen: Comparative techno-economic and environmental investigation, *Renewable and Sustainable Energy Reviews* 165, 112556.
- Nexant Inc., 2008, H2A hydrogen delivery infrastructure analysis models and conventional pathway options analysis results.
- Numazawa T., Kamiya K., Utaki T., Matsumoto K., 2014, Magnetic refrigerator for hydrogen liquefaction, *Cryogenics* 62, 185-192.
- Payne G.A., Palmer C.M., Brill J.P., Beggs H.D., 1979, Evaluation of inclined-pipe, two-phase liquid holdup and pressure-loss correlation using experimental data, *Journal of Petroleum Technology* 31, 1198-1208.
- Restelli F., Jiao F., Norris B., Trusler J.P.M., Siahvashi A., May E.F., Pellegrini L.A., Johns M., Al Ghafri S.Z.S., 2025, Dynamic simulation of a liquefied hydrogen export terminal, under review in *Energy*.
- Restelli F., Spatolisano E., Pellegrini L.A., Cattaneo S., de Angelis A.R., Lainati A., Roccaro E., 2024, Liquefied hydrogen value chain: A detailed techno-economic evaluation for its application in the industrial and mobility sectors, *International Journal of Hydrogen Energy* 52, 454-466.
- Rogers, H., 2018, LNG Shipping Forecast: costs rebounding, outlook uncertain.
- Shet S.P., Priya S.S., Sudhakar K., Tahir M., 2021, A review on current trends in potential use of metal-organic framework for hydrogen storage, *International Journal of Hydrogen Energy* 46, 11782-11803.
- Śliwa T., Kruszewski M., Zare A., Assadi M., Sapińska-Śliwa A., 2018, Potential application of vacuum insulated tubing for deep borehole heat exchangers, *Geothermics* 75, 58-67.
- Statista, Price of electricity among households and businesses in Algeria as of June 2023, www.statista.com/statistics/1283693/price-of-electricity-among-households-and-businesses-in-algeria (accessed 17 October 2024).
- Walas S.M., 1998, *Chemical process equipment: selection and design*.