

# Operating Procedures to Mitigate Greenhouse Gas Emission Caused by Front-End Failures in Petrochemical Plants

Chuei-Tin Chang\*, Guan-Wun Chen

Department of Chemical Engineering, National Cheng Kung University, Tainan, Taiwan 70101

[ctchang@mail.ncku.edu.tw](mailto:ctchang@mail.ncku.edu.tw)

A subprocess that facilitates product generation in petrochemical plant is generally referred to as the “front end.” The additional hardware items followed behind are usually used for purification purpose and named as the “back-end” units. In a realistic manufacturing environment, it is almost impossible to avoid equipment failure(s) after a long period of operations. Obviously, a set of proper actions must be taken to dissipate the inevitable emission of greenhouse gases emitted through the flare stacks. It is thus necessary to figure out effective counter measures during the design stage against such incidents predicted a priori. Our research objective here is to conjecture a few operating strategies to eliminate/reduce such air pollution induced by the front-end failures on the basis of sound engineering judgment, previous operational experiences and rigorous simulation results. Although this heuristic approach may not be as rigorous as those created by the popular AI tools, the resulting operating procedure(s) should at least be reliable and can be used as the foundation for further improvements. Note also that this procedure synthesis methodology may be carried out much more quickly without the need to secure a large amount of training data in advance. Finally, this back-end manipulation protocol may also be applied to other chemical plants after malfunction(s) develops in the front end.

## 1. Introduction

As the undesirable effects of global warming become apparent, suppression of greenhouse gas (GHG) emission has become a critical issue for keeping the petrochemical industries sustainable. According to Murphy and Allen (2005), these gases may include: methane, ethylene, propylene, butylene and butadiene, etc. Naphtha cracking is a typical GHG-emitting process, which is utilized in the present paper as a working example for illustration convenience.

In a sense, all chemical processes can be structurally characterized with two subprocesses placing next to each other in series. The subprocess in front is adopted primarily to produce a mixture that contains the target product(s), the unreacted reactants, by-products and other wastes. This mixture is then sent to the subprocess at the back end to purify all its components. Chenevert et al. (2005) proposed a so-called “tail-chase” strategy to reduce 75-80% of the total amount of gaseous compounds flared during start-up and/or shutdown. This nonconventional operation can be easily facilitated with a few extra compressors, pumps, pipelines, valves and fittings to recycle all streams from the exits of back end to the inlets of the same subprocess. Notice that the tail-chase tactic completely avoids sending the GHGs to the flare stack(s), and its operational safety and feasibility has already been confirmed by Xu et al. (2020) for the ethylene plant. To expedite realization of tail-chase operation, Yang et al. (2010) suggested that rigorous dynamic simulation may be utilized as a virtual alternative to reduce operator training cost. Wang et al. (2014) synthesized shutdown procedures of the naphtha cracking plant also by making use of dynamic simulation. Wang et al. (2016) in a later study showed with dynamic simulation that, by recycling the downstream liquid and vapor products to the inlet of cracked gas compressor, it is possible to significantly reduce GHG emission during the start-up and shutdown phases of this ethylene production process.

Other than the much-discussed tail-chase strategy, notice that in even earlier literature researchers also suggested to run all columns in total-reflux mode. Gani et al. (1998) dynamically simulated the total-reflux operation in an unsteady process to demonstrate that this operating strategy can indeed be utilized to reduce

GHG emission, while Reepmeyer et al. (2003) also adopted the total-reflux scheme to facilitate start-up of a distillation column.

From the above reviews, one can see that the tail-chase and total-reflux strategies were both utilized to handle routine start-up and shutdown of the typical chemical plants. In the present study, these start-up/shutdown experiences are extended to navigate the back-end subprocess in abnormal scenarios that may occur in a naphtha cracking plant. Experiences gained from procedure synthesis in this working example may again be extended to other processes of the same structure. Due to space limitation, discussions in the current paper focus only on operating the back-end subprocess, i.e., the distillation train. On the basis of the plant operational experiences gained by Reepmeyer et al. (2003), Chenevert et al. (2005) and in many other operation-related studies, e.g., Ge et al. (2021), new improvements have been developed in the present work for use to synthesize remedial measures against the anticipated failures. Specifically, these measures are supposed to be useful for manipulating the separation systems against the incidence of a front-end equipment breakdown in the naphtha cracking plant. More specifically, the original structure of distillation train is altered for the purpose of performing tail-chase and total-reflux operations so as to minimize the total quantity of emitted GHGs and also the total financial loss in cases when the upstream feed supply is interrupted due to front-end failures. The detailed operation steps have been developed according to the above-mentioned heuristic tactics, while feasibility and effectiveness of these procedures were confirmed with credible commercial software, e.g., ASPEN PLUS DYNAMICS<sup>®</sup>.

## 2. Emergency response operations

The emergency response operations considered here are supposed to be performed sequentially. The entire plant is assumed to be operated at the designated steady state during the initial period but, after a long span of continuous operation, the process stream(s) between the front and back ends may be discontinued due to one or more front-end failure (e.g., reactor outage, pump or compressor malfunction) taking place unexpectedly. According to the operational experiences reviewed above, the tail-chase and total-reflux tactics may be implemented to avoid excessive GHG emission. If, at a later instance, the failed unit is repaired and brought back to normal, the aforementioned process stream(s) naturally should resume and a recovery procedure is then executed to steer the system to its original condition.

## 3. Steady-state naphtha cracking process

A complete process flow diagram (PFD) of naphtha cracking can be found in Yang et al. (2010). For the sake of facilitating clear illustration, only the distillation train formed by de-ethanizer, de-propanizer and de-butanizer in this PFD is treated as the back-end subprocess in this study. Notice that these three individual columns are labelled as T-4001, T-4501 and T-5001, respectively, and this 3-column subprocess features two external feed streams and four product streams (see Figure 1). To quantitatively describe the tail-chase and total-reflux configurations for emergency response, the flowrates and compositions of these overall system inputs and outputs are fixed initially at those obtained by simulating the normal steady-state back-end subprocess with ASPEN PLUS<sup>®</sup>. Also, to avoid unnecessarily tedious analysis, any trace amount of species in every such stream has been ignored and only the flowrates of its predominant components are given in Table 1.

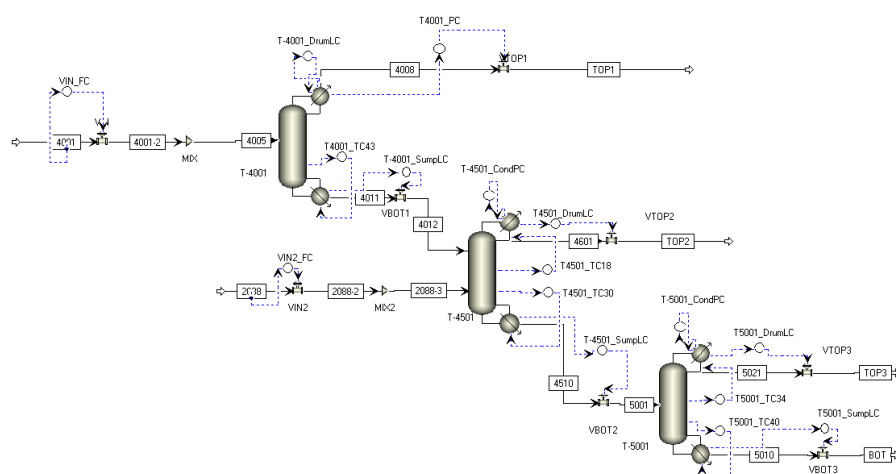

Figure 1: Process flow diagram of a portion of the back-end of ethylene plant during normal operation

Table 1: Predominant components and their weight percentages (wt %) in the overall input and output streams of a 3-column distillation train in the naphtha cracking process

Component	Stream 4001	Stream 2088	Stream TOP1	Stream TOP2	Stream TOP3	Stream BOT
C <sub>2</sub> H <sub>2</sub>	0.63	-	1.10	-	-	-
C <sub>2</sub> H <sub>4</sub>	47.12	-	81.51	-	-	-
C <sub>2</sub> H <sub>6</sub>	10.03	-	17.34	-	-	-
C <sub>3</sub> H <sub>4</sub>	0.66	1.38	-	3.34	-	-
C <sub>3</sub> H <sub>6</sub>	27.24	10.60	-	90.77	-	-
C <sub>3</sub> H <sub>8</sub>	1.89	-	-	5.87	-	-
C <sub>4</sub> H <sub>6</sub>	4.35	11.10	-	-	33.79	-
C <sub>4</sub> H <sub>8</sub>	6.51	18.42	-	-	53.68	-
C <sub>4</sub> H <sub>10</sub>	1.54	4.32	-	-	12.21	-
C <sub>5</sub> H <sub>10</sub>	-	26.10	-	-	-	*
C <sub>6</sub> H <sub>6</sub>	-	12.83	-	-	-	*
C <sub>7</sub> H <sub>8</sub>	-	1.80	-	-	-	*
C <sub>7</sub> H <sub>14</sub>	-	13.05	-	-	-	*

\*: significant amount; -: trace

#### 4. Tail-chase operating procedure

The tail-chase operating procedure used for handling an identifiable front-end failure consists of four steps:

**Step 1: construction of process structure.** Let us consider the PFD in Figure 1 together with the mass-balance data in Table 1 first. If the targeted abnormal incident occurs, the two inlet valves VIN and VIN2 must be closed to cut off the external feeds completely. In addition, all output streams of the distillation train should be recycled to the inlet mixers MIX and MIX2 after shutting down VTOP1, VTOP2, VTOP3 and VBOT3 on the outgoing product lines. The tail-chase configuration can be constructed according to the following considerations.

- Since C<sub>2</sub>'s is not present in the second feed stream 2088 and C<sub>2</sub>'s are the major components of the first feed stream 4001 according to Table 1, splitting TOP1 is not needed. Thus, TOP1 should be recycled only to MIX.
- Since the overhead product stream TOP2 of column T-4501 contains almost only C<sub>3</sub>'s and they are also present in streams 4001 and 2088, it is reasonable to split TOP2 according to a properly selected flow fraction (denoted as X<sub>C<sub>3</sub>s</sub>) and send the resulting streams to mixers MIX and MIX2, respectively. The flow fraction to MIX can be estimated as follows

$$X_{C_{3s}} \approx F_{C_{3s}}/TOP2_{C_{3s}} \quad (1)$$

where, F<sub>C<sub>3</sub>s</sub> is the total mass flowrate of C<sub>3</sub>'s in the first feed and TOP2<sub>C<sub>3</sub>s</sub> denotes the approximated mass flowrate of TOP2. Eq(1) can be established from the facts that TOP2 contains almost only C<sub>3</sub>'s and the mass fraction of C<sub>3</sub>'s is significant in the feed 4001 to column T-4001. Thus, from the mass-balance data in Table 1, X<sub>C<sub>3</sub>s</sub> can be estimated to be 0.86.

- Since the overhead product stream TOP3 of column T-5001 contains almost only C<sub>4</sub>'s and they also present in feed streams 4001 and 2088, it should be split into two and send them to MIX and MIX2, respectively. The mass-flow fraction of the split stream directed to MIX (denoted as X<sub>C<sub>4</sub>s</sub>) can be estimated by using Eq(2) below according to the same rationale behind Eq(1).

$$X_{C_{4s}} \approx F_{C_{4s}}/TOP3_{C_{4s}} \quad (2)$$

where, X<sub>C<sub>4</sub>s</sub> can be approximated with the total mass flowrate of C<sub>4</sub>'s in the first feed stream and the total mass flowrate of stream TOP3. On the basis of the corresponding data listed in Table 1, the value of X<sub>C<sub>4</sub>s</sub> is approximately 0.47.

- Stream BOT should be sent only to mixer MIX2 before column T-4501 since C<sub>5</sub>'s and the heavier hydrocarbons are present in stream 2088 but none in stream 4001 (see Table 1).

The process flow diagram for tail-chase operation (shown in Figure 2) can be established on the basis of the above design analysis.

**Step 2: identification of necessary operator tasks.** Failure occurrence and repair completion are assumed to be observable events in this study. The former enables a set of operator actions to build the recycle structures in Figure 2 and then to carry out the subsequent tail-chase operation, while the latter initiates another set of actions to disconnect the above loops and then drive the system back to the original steady state. To facilitate quick return from tail-chase to normal state after fixing the front-end failure, it is desirable to manipulate the back end during the tail-chase period to ensure that the distillation train embedded in the tail-chase structure closely mimics the normal conditions listed in Table 1 and Figure 1. To achieve this goal, it may be necessary to

simultaneously adjust all heating and cooling duties in the tail-chase system (see Figure 2) for the purpose of creating the desired pressure drops between the consecutive columns.

**Step 3: synthesis of detailed steps.** As mentioned previously, the proposed heuristic approach is adopted to identify specific steps in the tail-chase operation to significantly reduce GHG emission resulting from the front-end failures. One of the best feasible procedures identified so far is expressed with a sequential function chart (SFC) and presented in Figure 3. More detailed description of this SFC can be found elsewhere (Chen, 2024).

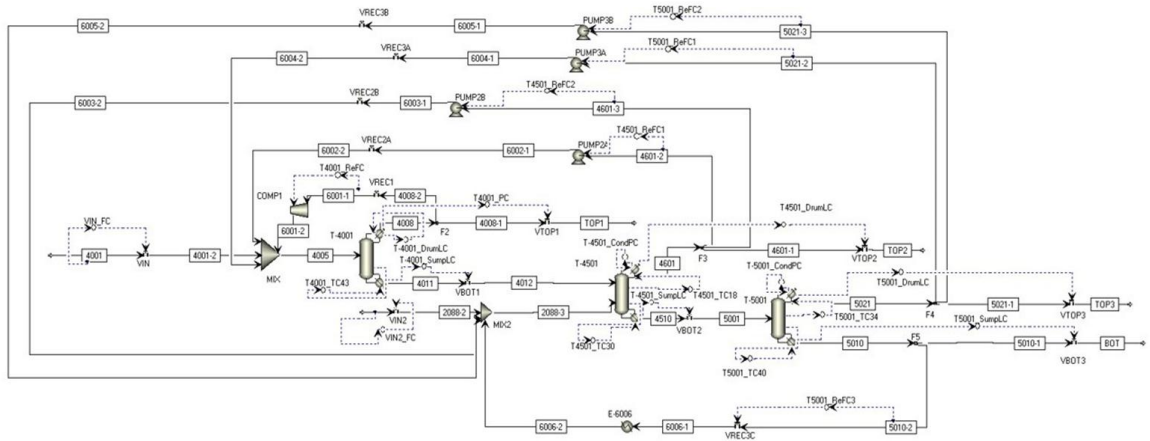

Figure 2: Process flow diagram of tail-chase operation

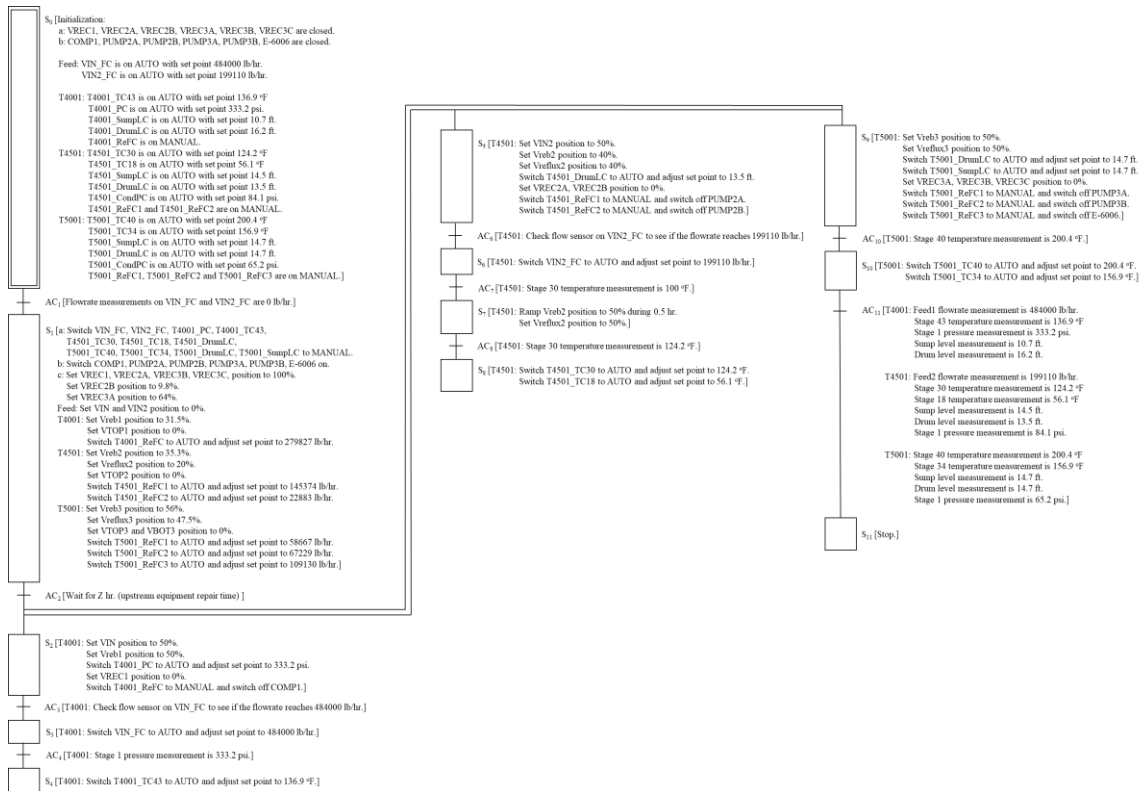

Figure 3: Sequential function chart of tail-chase operation

**Step 4: validation via rigorous simulation.** The operating procedure in Figure 3 was validated via rigorous numerical experiments performed with ASPEN PLUS DYNAMICS<sup>®</sup>. By setting the repair time in Figure 3 to be 5 hours and 15 hours, respectively, in AC<sub>2</sub>, i.e., Z = 5 and 15, the impacts of feed-interruption duration can be clearly observed from the corresponding simulation results, and it was concluded that the proposed operating procedure is safe, feasible and effective. These results are nonetheless omitted in this paper due to save space.

## 5. Total-reflux operating procedure

To prevent excessive GHG emission, the total-reflux operation can be used as a potential alternative. Similar to the synthesis of tail-chase procedure, the operating procedures in the present were built in essentially the same four steps reported previously. Generally speaking, after detecting the front-end failure, all inlet and outlet valves of every column in the back end should be closed so as to allow each column to be run independently. In other words, the resulting process structure can be thought of as a disconnected version of the original distillation train shown in Figure 1. One procedure is presented below in Figure 4, while the detailed description of this SFC is again omitted for the sake of brevity. The interested readers may find this material in Chen (2024)

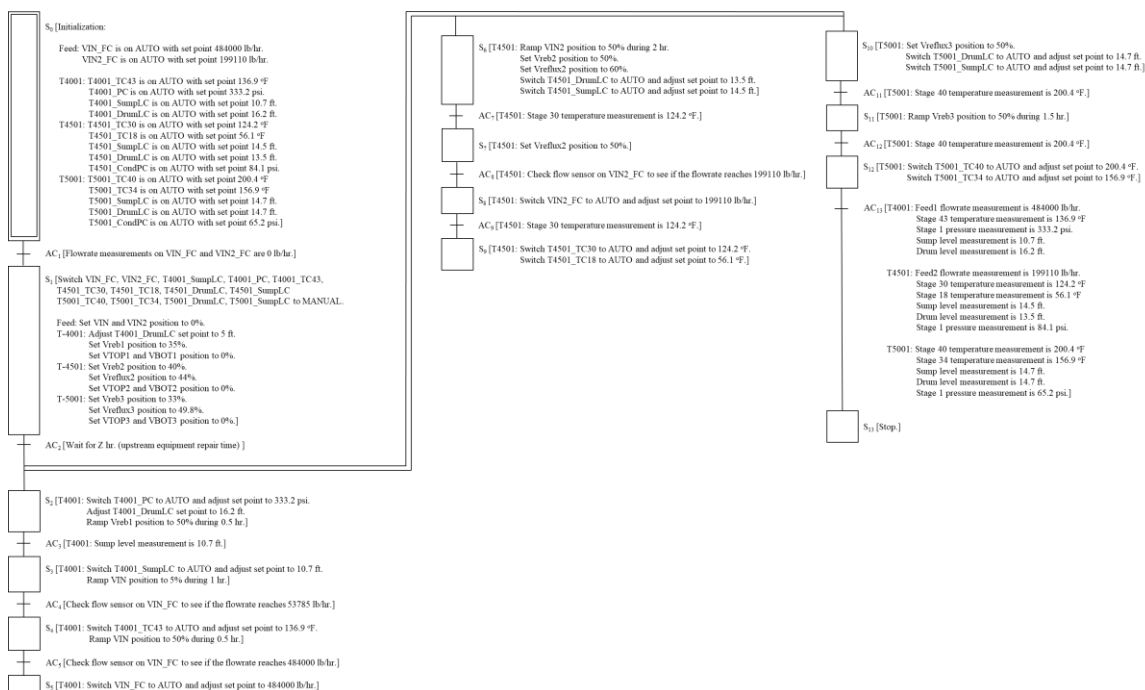

Figure 4: Sequential function chart of total-reflux operation

## 6. Impacts of repair time

Although the above procedure synthesis steps were tested only in the working example, the proposed method is expected to be generalizable. Rigorous simulation data were generated for two typical repair times ( $Z$ ) in implementing the procedures given in Figures 3 and 4. An important criterion can then be established accordingly to select the proper emergency response strategy in any specific scenario. This same selection approach can be adopted for running the other chemical processes in a straightforward fashion.

### 6.1 Short-term repairs

Let us first assume that the front-end equipment failure(s) in the above naphtha cracking plant is expected to be repaired in 5 hours. Tables 2 and 3 show summaries of GHG emission (mainly from column T-4001) and utility consumption amounts in reboilers and condensers obtained from simulation results generated respectively by applying the tail-chase and total-reflux operating strategies. Based on the overall GHG emission abatement capability, the former strategy seems to be a better choice if the repairing job can be completed in a relatively short time period.

Table 2: Total amounts of off-spec products and consumed energy caused by using alternative operating procedures to mitigate effects of front-end failure(s) in a naphtha cracking plant within 5 hours

Operating strategy	Amount of off-spec product (lb)	Energy consumed (MBtu)			Total operation time (hr)
		Condenser	Reboiler	Total	
Tail chase	4868688.6	-1806.4	2265.1	4071.6	14.6
Total reflux	5272140.3	-1761.6	2058.1	3819.7	15.4

*Table 3: Total amounts of off-spec gas and liquid products produced by using alternative operating procedures to mitigate effects of front-end failure(s) within 5 hours*

Operating strategy	Gaseous off-spec product (lb)	Liquid off-spec product (lb)
Tail chase	2357078.0	2511610.6
Total reflux	2571283.3	2700857.0

## 6.2 Long-term repairs

The analysis presented here was performed according to the prediction that repair lasts 15 hours. The performances of the two proposed strategies are again compared in Tables 4 and 5 according to GHG emission levels and energy consumption amounts. Thus, it seems that the total-reflux procedure performs better in terms of overall GHG emission abatement capability if the upstream failure(s) lasts in a relatively long period of time.

*Table 4: Total amounts of off-spec products and consumed energy caused by using alternative operating procedures to mitigate effects of front-end failure(s) in a naphtha cracking plant within 15 hours*

Operating strategy	Amount of off-spec product (lb)	Energy consumed (MBtu)			Total operation time (hr)
		Condenser	Reboiler	Total	
Tail chase	5689497.0	-3175.6	3988.9	7164.5	26.8
Total reflux	6201383.6	-2812.0	3158.3	5970.3	27.0

*Table 5: Total amounts of off-spec gas and liquid products produced by using alternative operating procedures to mitigate effects of front-end failure(s) within 15 hours*

Operating strategy	Gaseous off-spec product (lb)	Liquid off-spec product (lb)
Tail chase	2995042.0	2694454.9
Total reflux	3010887.2	3190496.4

## 7. Conclusions

Both tail-chase and total-reflux operations have been demonstrated in extensive simulation studies to be potentially effective for eliminating GHG emission caused by the front-end failure(s) in a naphtha cracking plant. The simulation results suggest that the former is preferred for the short-term response needs and the latter is useful in long-term scenarios. Notice especially that the heuristic approach proposed here may be extended to operate the back end of any other chemical plant with the same process structure after malfunction(s) develops in the front end. This generalizable feature is considered to be the most useful contribution of the present study.

## References

- Chen, G.W., 2024, Shutdown and emergency response procedures for separation sequences in chemical plants, MS Thesis, National Cheng Kung University, Tainan, Taiwan.
- Chenevert, D., Harry, C.J., Unterbrink, B., Cain, M., 2005, Flare minimization practices improve olefins plant start-ups, shutdowns, *Oil & Gas Journal*, 103(33), 54-60.
- Gani, R., Jepsen, T.S., Perez-Cisneros, E.S.A., 1998, Generalized reactive separation unit model - modelling and simulation aspects, *Computers & Chemical Engineering*, 22, S363-S370.
- Ge, S., Xu, Y., Wang, S., Xu, Q., Ho, T., 2021, A win-win strategy for simultaneous air-quality benign and profitable emission reduction during chemical plant shutdown operations. *Process Safety and Environmental Protection*, 147, 1185-1192.
- Murphy, C.F., Allen, D.T., 2005, Hydrocarbon emissions from industrial release events in the Houston-Galveston area and their impact on ozone formation, *Atmospheric Environment*, 39(21), 3785-3798.
- Reepmeyer, F., Repke, J.U., Wozny, G., 2003, Analysis of the start-up process for reactive distillation, *Chemical Engineering & Technology*, 26(1), 81-86.
- Wang, Z., Xu, Q., Ho, T.C., 2014, Emission source characterization during an ethylene plant shutdown, *Chemical Engineering & Technology*, 37(7), 1170-1180.
- Wang, S., Zhang, J., Wang, S., Xu, Q., 2016, Dynamic simulation for flare minimization in chemical process industry under abnormal operations, *Current Opinion in Chemical Engineering*, 14, 26-34.
- Xu, Y., Dinh, H., Xu, Q., Eljack, F.T., El-Halwagi, M.M., 2020, Flare minimization for an olefin plant shutdown via plant-wide dynamic simulation, *Journal of Cleaner Production*, 254, 120129.