

# A Bayes Network to Predict the Equipment Deterioration in an Atmospheric Distillation Unit

Antonino Giacobbe<sup>a,\*</sup>, Giuseppa Ancione<sup>a</sup>, Maria Francesca Milazzo<sup>a</sup>, Fabrizio D'Antonio<sup>b</sup>, Elpida Piperopoulos<sup>a</sup>

<sup>a</sup>Department of Engineering, University of Messina, Contrada di Dio, 98166 Messina, Italy

<sup>b</sup>Raffineria di Milazzo S.C.p.A., Contrada Mangiavacca, 98057 Milazzo (ME), Italy

Accessing big data from the continuous monitoring of process assets in industrial plants allows for the prediction of equipment deterioration. This promotes a digital transition process in order to monitor risk in major accident plants.

This work is a further implementation of a previous developed approach to predict the equipment deterioration in an atmospheric distillation unit, which is based on the prediction of the residual useful life (RUL) and the associated risk of plant sections subject to naphthenic acid corrosion and sulphidation. Nowadays, in fact, there is a growing attention to extract heavy and sour crude oils as they are cheaper and so more profitable than sweet oils, but they require higher costs to ensure the integrity of the equipment and a higher associated risk, related to high quantities of sulphur compounds, metals and other impurities.

To manage corrosion mechanisms and to update the RUL, an approach based on a Bayes network is improved and tested by means of its application to a real case study. It is applied to 4 critical sections of an atmospheric distillation unit of the Milazzo refinery (Messina), i.e. two sections upstream the column and two side cuts. Parameters taken into consideration are metallurgies, feedstock features, temperatures, plant conditions and performed inspections during 9 months in operation.

## 1. Introduction

In recent decades, Oil companies have focused on the extraction, refining and distribution of higher acid crudes: these are cheaper than sweet crudes, but they contain high amounts of heavy hydrocarbons, aromatics, sulphur compounds and metals. This results in high corrosion rates, higher costs to maintain plant integrity and increased associated risk. To mitigate or to control these phenomena, refineries often adopt continuous corrosion monitoring systems or metallurgy upgrades. In atmospheric and vacuum distillation units, the main damage mechanisms are naphthenic acid corrosion and sulfidation. Naphthenic acids have the basic formula  $C_nH_{2n+z}O_2$ , being  $n$  the number of carbon atoms and  $z$  the hydrogen vacancies: they are not corrosive at room temperature, they become corrosive around 200 °C for carbon steels, they reach their peak reactivity around 350 °C and then it decreases above 400 °C (Al-Moubaraki and Obot, 2021). The parameters of influence are manifold, but it is closely related to TAN. Sulfidation is a high temperature corrosion mechanism (230–425 °C) in which sulphur separates from sulphur compounds, it diffuses into the base metal along grain boundaries, and it compromises the structure (Rebak, 2011); this mechanism is not completely known yet, as the high number of reactions that contribute, but it is closely related to the sulphur content.

Monitoring process parameters is the basis of the CBM (Condition-Based Maintenance), in which data are recorded, acquired and processed to determine the health status of an item (Rosmaini and Shahrul, 2012). It belongs to the predictive maintenance techniques family that, through probes, sensors and NDT (Non-Destructive Tests), monitors the conditions of the assets and processes the data through mathematical models to provide performance indicators. From the interpretation of these performance indicators, it is possible to establish maintenance actions to engage and the time intervals to attend.

This work resumes the Bayesian model conceived by Ancione et al. (2023) and then applied in the preheating section of an atmospheric distillation unit of the Milazzo refinery (Giacobbe et al, 2024). Here the model foresees a monitoring period of 9 months, and it considers four critical sections of the distillation column. The model allows a dynamic update of the residual useful life of the sections involved and an update of the risk level with respect to the expected risk. To achieve this goal, parameters taken into consideration are crudes characteristics, process variables (temperatures), physical aspects (current plant conditions) and maintenance aspects (inspections frequency and items criticality).

## 2. Methodology

The model is based on the Bayes' theorem: given two events A and B with nonzero probabilities, the conditional probability of A with respect to B is given by the product of the conditional probability of B with respect to A and the probability of A, divided by the probability of B (Pearl, 1988):

$$P(A|B) = \frac{P(B|A) \cdot P(A)}{P(B)} \tag{1}$$

Bayes networks are very effective in reliability analyses to estimate random failures at random intervals and to estimate a posteriori probability of unknown variables from knowledge of experimental evidence.

The proposed approach consists of a Bayes network model represented by 9 nodes, 6 of them are independent variables and 3 dependent variables. The independent nodes (or parent nodes) are *Sulphur*, *TAN*, *Temperature*, *Initial Conditions*, *Inspections frequency* and *RBI Criticality*; the dependent nodes (or child nodes) are *Corrosion Rate* (CR), *Consumed Life* ( $\Delta$ RUL) and *Risk Index* (k). The CR node is a child of *Sulphur*, *TAN* and *Temperature* nodes, according to the Standard API 581 (2016). The  $\Delta$ RUL node depends on *Initial Condition* and CR, whereas the k node depends on consumed life  $\Delta$ RUL, *Inspections Frequency* and *RBI Criticality*. Concerning the *Inspections Frequency* node, it regards when the next inspection will be performed, whereas the *RBI Criticality* node takes into account the criticality level defined in the last performed RBI (Risk- based Inspection). Figure 1 shows the network structure; the variables are discretized according to the criteria established in Table 1 and 2; the relationships between CR and *Initial Conditions* are shown in Table 3, those regarding the Risk Index node are reported in Table 4.

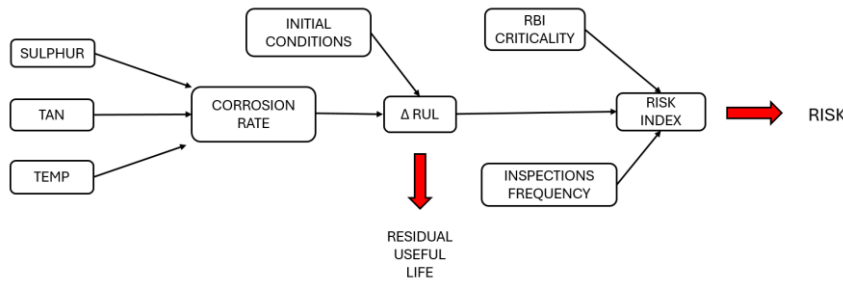

Figure 1. Structure of the suggested Bayesian network

Table 1. State definition of Sulphur, TAN, Temperature, and Corrosion Rate.

Sulphur [S%]		TAN [mgKOH/g]		Temperature [°C]		CR [mm/y]	
State name	Range	State name	Range	State name	Range	State name	Range
S1	≤ 0.3	S1	≤ 0.3	S1	≤ 232	Very_Low	≤ 0.075
S2	0.3 – 0.5	S2	0.3 – 0.65	S2	232 - 260	Low	0.075 – 0.15
S3	0.5 – 1.05	S3	0.65 – 1.5	S3	260 - 288	Med_Low	0.15 – 0.25
S4	1.05 - 2	S4	1.5 – 3.0	S4	288 - 315	Medium	0.25 – 0.35
S5	2 – 2.75	S5	> 3.0	S5	315 - 343	Med_High	0.35 – 0.50
S6	> 2.75			S6	343 - 371	High	0.50 – 1
				S7	371 - 392	Very_High	1 – 1.5
				S8	> 392	Highest	> 1.5

Table 2. State definition of Initial Condition, Inspections frequency, and RBI Criticality nodes.

Initial Conditions		Inspections Frequency		RBI Criticality	
State name	Range [%]	State name	Range [months]	State name	Value
Normal	10 - 100	S1	≤ 12	S1	Low
Warning	5 - 10	S2	13 - 24	S2	Medium Low
Pre-Critical	2 - 5	S3	> 24	S3	Medium
Critical	≤ 2			S4	Medium High
				S5	High

Table 3. Definition of Consumed Life ( $\Delta RUL$ ) node.

$\Delta RUL$		CR [mm/y]							
		Very Low	Low	Med-Low	Medium	Medium High	High	Very High	Highest
Initial Conditions	Normal	R	N	N	H	H	VH	VH	VH
	Warning	N	N	H	H	VH	VH	VH	VH
	Pre-Critical	N	N	H	H	VH	INT	INT	INT
	Critical	H	H	VH	INT	INT	INT	INT	INT

R = Reduced; N = Normal; H = High; VH = Very High; INT = Intolerable.

Table 4. Definition of Risk Index ( $k$ ) node.

RBI Criticality	Risk index $k$	Inspections Frequency [month]	$\Delta RUL$				
			Reduced	Normal	High	Very High	Intolerable
Low		≤ 12	L	L	ML	M	H
		13 - 24	L	L	ML	MH	H
		> 24	L	L	M	H	H
Med-low		≤ 12	L	L	ML	MH	H
		13 - 24	L	L	M	H	H
		> 24	L	L	M	H	H
Medium		≤ 12	L	L	M	MH	H
		13 - 24	L	L	M	H	H
		> 24	ML	ML	MH	H	H
Med-High		≤ 12	ML	ML	MH	H	H
		13 - 24	ML	M	H	H	H
		> 24	ML	M	H	H	H
High		≤ 12	MH	H	H	H	H
		13 - 24	MH	H	H	H	H
		> 24	H	H	H	H	H

L = Low; ML = Medium Low; M = Medium; MH = Medium High; H = High.

The *Residual Useful Lifetime* (RUL) is obtained by subtracting the life consumed from the reference period, usually 10 years (expressed in days), as given by Eq. (2):

$$RUL = 3650 - \Delta RUL \quad (2)$$

The *Consumed Life* ( $\Delta RUL$ ), also expressed in days, is calculated by Eq. (3):

$$\Delta RUL = [0.5 p_1 + 1 p_2 + 2 p_3 + 3 p_4 + 4 p_5] \Delta t \quad (3)$$

where  $p_n$  are the states probabilities of  $\Delta RUL$  node and  $\Delta t$  is the time interval considered, whereas the numerical coefficients represent the states weights.

The  $k$  parameter represents the weighted average of the node's probabilities, and it is calculated with Eq. (4). It is defined like a coefficient that amplifies or reduces the overall risk value, changing the position of the equipment in the Risk matrix, in the considered plant section and after the examined time interval:

$$k = f_1 r_1 + f_2 r_2 + f_3 r_3 + f_4 r_4 + f_5 r_5 \quad (4)$$

where  $f_i$  coefficients represent the weights assigned for each state of the  $k$  node and  $r_i$  the states probabilities of the same node. The updated risk ( $R_{update}$ ) value is, finally, given by (Eq. 5):

$$Risk_{update} = k \cdot Risk_{initial} \quad (5)$$

Considering that, for a given scenario, the consequences remain the same, the likelihood is the only updated parameter, as given in (Eq. 6):

$$POF_{update} = k \cdot POF_{initial} \quad (6)$$

The numerical values of the coefficients have been defined by imposing known inputs on the network and recording the output; meanwhile, the following observations are made:

- if  $\Delta RUL_{up} = \Delta T_{ref} \rightarrow R_{update} = R_{initial} \rightarrow k = 1$ ;
- if  $\Delta RUL_{up} < \Delta T_{ref} \rightarrow R_{update} < R_{initial} \rightarrow k < 1$ ;
- if  $\Delta RUL_{up} > \Delta T_{ref} \rightarrow R_{update} > R_{initial} \rightarrow k > 1$ .

It is assumed a quadratic law to represent the  $k$  values as the ratio  $\Delta RUL_{up}/\Delta t$  varies, obtaining the coefficients shown in Table 5:

Table 5. Coefficients for the  $k$  index calculation.

Risk Index coefficients					
	$f_1$	$f_2$	$f_3$	$f_4$	$f_5$
If $\Delta RUL \leq \Delta t$	0.16	0.25	0.49	0.81	1.00
If $\Delta RUL > \Delta t$	0.81	1.00	1.21	1.69	2.25

### 3. Case study

The presented case study is an atmospheric distillation unit of the Milazzo Refinery, for processing high sulphur crude oils. Four critical sections were examined, identified in Figure 2:

- the second preheating train (E8 A/H exchangers);
- the transfer line down to the furnace (F1);
- heavy gasoil side cut (pipeline 6"-P1404);
- atmospheric residue extraction (E25 exchanger).

To each of them is associated an integrity operating window IOW (API RP 584, 2014). Materials, degradation mechanism, nominal conditions and IOW codes of the analysed sections are given in Table 6.

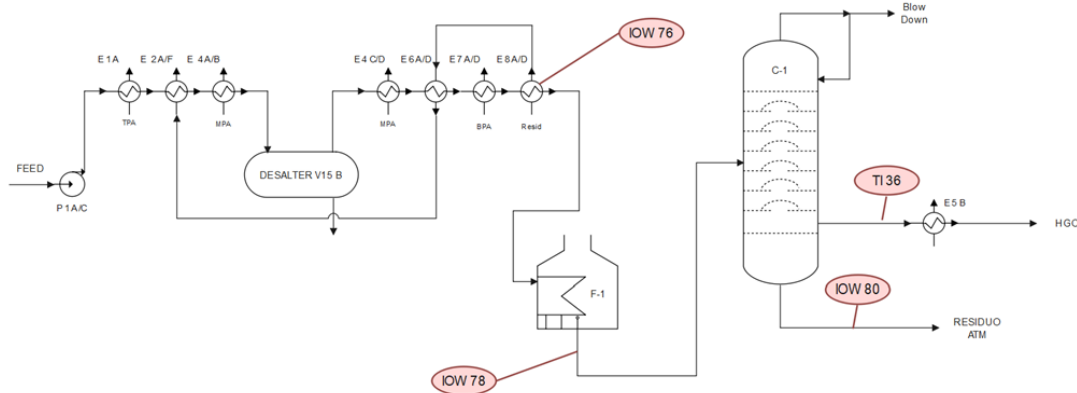

Figure 2. Simplified P&I diagram of the first part of the examined distillation unit and the IOW locations

Table 6. Characteristics and nominal conditions of the items.

Item	IOW	Damage Mechanism	Material	T <sub>N</sub> [°C]	S <sub>N</sub> [wt %]
E-8	76		Carbon Steel	266	3.3
F-1	78	High Temperature Sulfidic	5 Cr	362	3.3
6"-P1404	36	and Naphthenic Acid Corrosion	5 Cr	350	5.7
E25	80		5 Cr	350	5.7

T<sub>N</sub> nominal temperature, S<sub>N</sub> nominal sulphur percentage.

#### 4. Results and discussion

For the sake of brevity, only the results for the first analysed equipment are reported here. Figure 3 provides the feed data characterised by Sulphur and TAN of the processed crudes in 9 months of operation (270 days); Figure 4 illustrates the hourly-detected temperatures, Figure 5 shows the bayesian network model, implemented in the software Netica, applied to the case study concerning the carbon steel item.

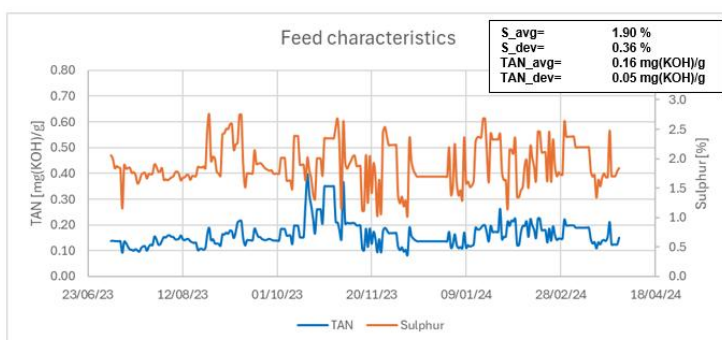

Figure 3. TAN and sulphur trends of the processed crudes in the examined period

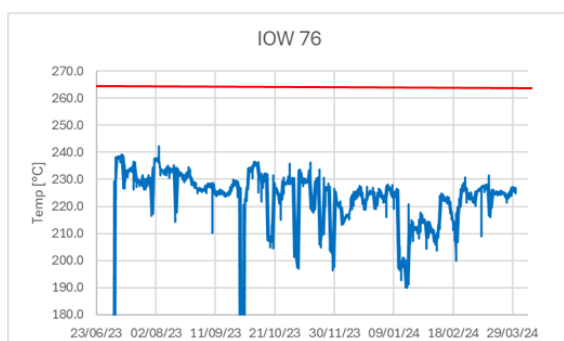

Figure 4. Temperature trend of the IOW 76 in the examined period and IOW temperature limit (266 °C)

The CR node has been trained according to the API 581, with respect for the High Temperature Sulfidic and Naphthenic Acid Corrosion mechanism for carbon steel. The initial condition of the examined equipment is "Normal" (between 10 and 100% of the design life), so the  $\Delta$ RUL estimated for the examined period has been about 137 days, that means the remaining useful lifetime is equal to 3513 days on a 10-year basis. This first result highlights a significantly reduced lifetime consumption compared to that expected, i.e. 270 days. Furthermore, considering that the RBI Criticality for the examined section is medium-high and that the next inspection will be performed in 24 months, the Risk index obtained is 0.251. This means that the updated risk of the plant section under current operating conditions is 25% of the initial risk. Knowing that the RBI probability of failure for the considered equipment is  $3.06 \times 10^{-5}$  (E category of the Risk Matrix), the updated probability of failure is  $7.69 \times 10^{-6}$ . Other two bad scenarios are considered to test the network with different conditions: the first one considers the same feedstock but higher temperatures, the second one considers higher temperatures and higher crude's acidity. The obtained results are summarised in Table 6.

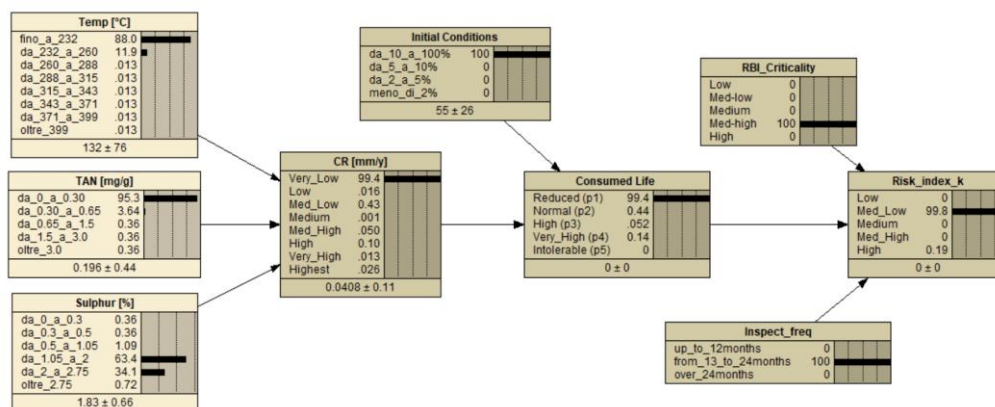

Figure 5. Bayesian network for the Carbon Steel crude preheating section

Table 6. Consumed life, risk index and updated probability of failure of the pre-heating section over 270 days; comparison between the three considered scenarios.

Scenario	Design	N.1	N.2	N.3
ΔRUL [days]	270	137	274	300
RUL [days]	3380	3513	3376	3350
k	1.00	0.251	1.067	1.183
Risk	Design	25 %	107%	118%
Probability of failure	$3.06 \times 10^{-5}$	$7.69 \times 10^{-6}$	$3.26 \times 10^{-5}$	$3.62 \times 10^{-5}$

## 5. Conclusions

The proposed approach comes from the combination of the concepts of Condition-Based Maintenance and the Bayes' conditional probability; it makes possible to determine the residual useful life and the risk level of a critical section, by varying the variables of influence of the damage mechanisms. In fact, by varying the characteristics of the processed feedstocks and the process variables, it is possible to have a significant variation in the corrosion rate. Knowing the corrosion rate and the risk level, it is possible to establish the plant utilisation and the maintenance strategy (extension or reduction of maintenance intervals), implementing mitigation techniques if the damage is excessive or processing more acidic crudes if the plant allows it.

However, the proposed model still has some limitations, which it is attempting to overcome: the main one concerns the values of the numerical coefficients for risk index calculation. In the future, it is expected to improve this criticality determining probability distributions with known inputs and imposing the same inputs on this network: so, it will be possible to determine k-values by comparing the corresponding outputs.

## References

- Al-Moubaraki A.H., Obot I.B., 2021, Corrosion challenges in petroleum refinery operations: Sources, mechanisms, mitigation, and future outlook, *Journal of Saudi Chemical Society*, 25, 10-14.
- Ancione G., Bartolozzi V., Bragatto P., Milazzo M.F., 2023, Monitoring Equipment Corrosion due to Sour Crude Oils: a Bayesian Approach, *Chemical Engineering Transactions*, 99, 337-342.
- API RP 581 (American Petroleum Institute), 2016, Risk-Based Inspection Methodology, 3rd ed. API Publishing Services, Washington (USA).
- API RP 584 (American Petroleum Institute), 2014, Integrity Operating Windows, 1st ed. API Publishing Services, Washington (USA).
- Giacobbe A., Ancione G., Milazzo M.F., D'Antonio F., Bragatto P., Piperopoulos E., 2024, Integrating IOW in the Estimation of the Risk of an Atmospheric Distillation Unit by Using a Bayesian Network, *Chemical Engineering Transactions*, 111, 85-90.
- Pearl, J., 1988, *Probabilistic Reasoning in Intelligent Systems: Network of Plausible Inference*, 1st edition Morgan Kaufmann, Los Angeles (USA).
- Rosmaini A., Shahrul K., 2012, An overview of time-based and condition-based maintenance in industrial application, *Computers & Industrial Engineering*, 63, 135-149
- Rebak R.B., 2011, Sulfidic corrosion in refineries – A review, *Corrosion Reviews*, vol. 29, p. 123-133.