

Electric Rail Traction for Induction Motor Control of Hybrid PWM strategy by using fuzzy logic controller

Ma Yinl, Zhu Cuihon, Ca Rui,

Tianjin Medical University Cancer Institute and Hospital, Tianjin
Department of Medical Oncology, Tianjin Medical University General Hospital, Tianjin
China National Clinical Research Center for Cancer; Key Laboratory of Cancer Prevention and Therapy; Tianjin's Clinical Research Center for Cancer, Tianjin

Abstract:-

Switching losses are minimised, and reliability is improved, by using a low shift frequency in the electrical rail traction induction control system. However, with low switching frequencies, the usual single pulse width modulation (PWM) approach across the full speed range might produce an excessive number of harmonic components that sequentially induce motor heating, torsion ripple, and other detrimental consequences. Hybrid PWM techniques are proposed in this research to achieve low losses and total harmonics supported by very low shift frequencies by combining carrier-based asynchronous and synchronous modulation and optimal synchronous modulation techniques. The findings and simulations of the hybrid PWM approach offered by a fuzzy logic controller were used as collateral.

Index Terms— Fuzzy logic controller, low switching frequency, hybrid pulse width modulation, smooth transition, and traction motor.

INTRODUCTION:-

Over time, acceptance engines aided by voltage source inverters (VSIs) will run the majority of electric rail footing frameworks [1]. Protected entryway bipolar transistors, which are often used in these inverters, are still the most common

implementation of these devices (IGBTs). Silicon carbide (SiC) and other wide-band gap semiconductor devices may be used to create inverters with lower losses and smaller diameters, but their current costs and power levels are unlikely to rise much in widespread usage. As a result, inverters

continue to be hindered by Si devices. Doping of Si devices may have improved their controllability and strength within a particular temperature range, but high exchanging and on-state mishaps may still produce superfluous intersection temperatures that might make the devices fizzle. In rail footing frameworks, it is common to use low exchanging frequencies to reduce IGBTs' exchanging mishaps and therefore increase their warm life and limit.

Since the introduction of electric drive in 1964 by A. Schonung and H. Stemmler [4], beat width tweak (PWM) systems have grown swiftly, and the general employed PWM systems for enlisting

vector PWM (SVPWM) are used. The ratio N_{cr} between the transporter and high recurrence areas decreases as the engine recurrence increases, which causes the converters to create an extensive number of synchronised segments and causes engine warming, torque swell and other adverse effects [7] [8]. As a contrast to this, uneven PWM (DPWM) approaches seem to reduce twisting at high N_{cr} levels at a given exchange repetition. [10]

Electric rail footing converters are often used in the low-recurrence and medium- to high-recurrence regions to regulate DC voltages using half and half PWM approaches, i.e., regular uninterrupted regulation, over modulation or synchronous balancing, then square wave. Currently, the majority of electric rail footing converters make use of cross-breed PWM techniques. Over modulation, focused 60 synchronous balance, and ideal synchronous balance are the most common approaches to the medium recurrence change zone. For the low-recurrence district, Mitsubishi and Toshiba were given synchronous SVPWM, which was then used across modulation I and II

engine drives have been discussed and thought about in [5]-[10]. By improving the exchanging modes, PWM techniques provide better DC transport voltage utilisation, improve converter noises and mishaps, and increase the yield recurrence range of three-stage converters and distinct markers [5], [7], [8]]. PWM methods supply the desired voltage as the primary goal. In addition to a large power, low exchanging recurrence, and a broad speed range, electric rail footing converters offer many other advantages. A single normal, nonstop balance is possible.

To control the entire speed range of the footing enlistment engine, strategies such as sinusoidal PWM (SPWM) or space

locations in order to simply switch to square wave. Basic, but with high fifth and seventh sub harmonics, making it necessary to develop a precise engine model to monitor basic current for shut circle current regulation and causing low repetition wavering when N_{cr} is less than 11.

ICE fast trains and China's first AC electric train AC4000 used focal 60 synchronous SPWM adjustment innovation, which can be easily implemented and has low exchanging misfortunes, despite the fact that it has high pinnacle engine streams and low-recurrence noises. The agents selected symphonious least PWM (SHEPWM) and current symphonious least PWM may achieve various advancement targets, in contrast, by using increased synchronous regulation techniques [7] (CHMPWM). ALSTOM and GE obtained the more developed SHEPWM invention, whereas SIEMENS used unconnected symphonious current simplifying synchronous regulation.

In light of this, the major focus of this study is to provide a more in-depth

explanation of the use of mixture PWM for rail footing engine control. The remainder of this document is organised as follows. A more accurate representation of the suggested half-and-half structure may be found in Area II, which displays the necessary half breed PWM computations.

II. HYBRID PWM ALGORITHMS:-

A. As previously discussed, IGBTs' calamities, music, adjustment records, and so on are all things to consider. For a real rail footing enlistment engine control, the use of a crossover PWM technique is a better choice. A steady recurrence offbeat PWM is used to avoid complicated count and advancements among synchronous PWMs with different Ncr in the low-recurrence region. PWM waveform asymmetry is a real problem as the key repetition increases; this means that standard synchronous PWM with triple and odd Ncr must be used until the direct regulation list is out of its range or sub harmonic segments are high [13], at which point OSPWM must be used. [12] Calculation of different PWMs is discussed in this section before a half-breed design for a real electric footing engine control is shown.

B. Asynchronous THIPWM Algorithm:-

For three-stage VSIs with significant Ncr adjustments, the most common balancing scheme is conventional SVPWM (CSVPWM), which aims to reduce THD while simultaneously increasing DC transport consumption [7], [8]. However, with CSVPWM, three-stage beats must be balanced in the meanwhile, making it insufficiently adaptive for smooth progress where current or torque influence must be kept at a safe distance.. In a cross-breed structure of the engine control framework, this article uses one-fourth-third-symphonious infusion PWM (THIPWM4). For low-recurrence locations with large Ncr tweak, the THD of THIPWM4 is extremely close to that of CSVPWM, at the expense of a minor reduction of

greatest DC transport usage [7]. An FPGA may do the calculation without a triangle count and yet achieve smooth progress for three-stage beats using this technique [8]. FIG. 1 depicts a typical electric rail traction voltage source converter in broad strokes.

The VSI for electric rail traction topology is shown in Figure 1.

The one-fourth third-harmonic injection three-phase voltages V_{XN} may be obtained from the figure, with regard to the DC bus negative point N [7]

Where

With regard to fictional DC centre tap 0, V_{x0} is phase voltage, and V_d is bus voltage.

Fundamental angle frequency (ω) and beginning phase (θ) are both defined as Phase shift between three-phase voltages, X , is the problem.

Its modulation wave is 0.093 to 0.907 cycles per second. As a result, the pink PWM pulse may be generated by comparing active-high to active-low.

Fig. 2. THIPWM schematic for CBPWM

C. Synchronous THIPWM Algorithm:-

As previously said, synchronous THIPWM is used to alter the interface between APWM and OSPWM, as previously stated. Nonconcurrent THIPWM's regulation calculation is extremely similar to that of synchronous control, the only difference being that the transporter's recurrence is not consistent, but is instead modified by critical recurrence and Ncr. In addition, NCR's reputation as an alternative must be maintained.

1 2 4

Zero to three and three to zero.

in order to complete each aspect of the project.

V_{Pn} to the peak voltage (which is $2V_d(13)$) is what defines the modulation index M , which in turn is determined by the basic peak phase-to neutral voltage

π

what is known as modulation

The highest value of M for THIPWM in the linear modulation range is 0.907 [13].

The three-phase reference modulation voltages V_{mx} may be represented as an FPGA implementation of the modulation method.

Fig. 2 shows an example of V_{ma} , which is represented by

There is no need to be concerned about the presence of triple subharmonics in a three-stage converter's separated, unbiased heap [13]. A 15-Ncr resistor is used in the synchronous regulation zone of the approach shown.

As a result, CSPWM and APWM may easily link at any level, and no further progress method is required, since they share the same bearer.

CHMPWM Algorithm:-

As of right now, the most widely-used OSPWMs for the disposal of low-arrange music are SHEPWM and CHMPWM, with SHEPWM being much more often used in applications in writing. Although SHEPWM has a drawback that causes non-ideal consonant hardship in an engine where the root-mean-square (RMS) swell current is exaggerated, the following more elevated quantity of music will be boosted close to the previously disposed of music. [13] as a result of which steady development will be more difficult (will be talked about later in the part "IV Smooth

Change Discussion"). As a result, CHMPWM is included in this investigation to get the lowest possible weighted THD (WTHDi)

To create CHMPWM, the wave depicted in Figure 3 may be employed, which is reliant on SHEPWM.

SHEPWM phase voltage wave with K number of angles (Fig. 3).

There are only odd harmonics in the sine wave, hence the phase to N voltage may be written as [7], [13] using a Fourier series. the number of notch angles $I K$, is the order of the harmonic, and V_k is its peak phase voltage value $I I$ for the k -th-order harmonic. For even and odd values of K , we use the +1 and -1 notation.

CHMPWM technique optimal protest is to minimise the THD of line current, which can be calculated from the stage voltage separated by the forceful spillage engine impedance [13]. For the articulation, the WTHDi, which is expressed as a unit of central line current [7], is preferable. This is how the results of the CHMPWM computation might be conveyed:

Using a PC software, the score edges might be iterated, avoiding look-into tables (LUTs) [25]. The primary extent may be managed and the amount of $K-1$ noises can be removed with by using K number of score points. Even if WTHDi can be reduced by increasing the number of indent heavenly attendees, the LUT will become absurdly large and more reasonable FPGA components will be needed. However, the Ncr of CSPWM and APWM is high enough to maintain high-quality tweak execution even in low-recurrence areas. For K , only 1, 2, 3, and 4 are accepted in this newly-introduced use.

D. Hybrid PWM Plan:-

This study proposes using APWM, CSPWM, OSPWM, and square-wave to control engine line current and reduce

throbbing torque at all speed ranges, in order to reduce the total harmonic distortion (THD) in the engine line current. The proposed cross-breed PWM can be planned as shown in Fig. 4, where the tweak strategies (bearer frequencies), DC transport voltage V, RMS line voltage $V_{ll}(rms)$, and ascertained aggregate loss of the converter P_{loss} are depicted against central recurrence for an electric rail footing framework with the fundamental parameters listed in Table I.

It can be observed from Figure 4 that the suggested APWM travels to square wave via 15-switch CSPWM (15-CSPWM) and 4 to 1 indent edges OSPWMs throughout the whole speed range (9-CHM to 3-CHM). Changes in line voltage are made by primary recurrence to fulfil motion and torque requirements, culminating in square-wave ($M = 1$), which has the fewest switch duties and minimises the successful engine current, as well as disasters. The yield line voltage necessitates a change in the DC transport voltage. It is not just the most severe available exchange rates that are used to alter the balance modes, but also the largest available adjustment files. The aggregation misfortune is reduced as the transporter recurrence decreases, but the conduction misfortune is increased as it travels to square wave mode.

$$\left\{ \begin{array}{l} \min: WTHD_i = \frac{1}{k} \sqrt{\sum_{k=5,7,11,\dots}^{\infty} \left(\frac{V_k}{V_1}\right)^2} \\ s.t.: M = \pm \frac{1}{k} [1 + 2 \sum_{i=1}^K (-1)^i \cos k \alpha_i] \\ s.t.: 0 < \alpha_1 < \alpha_2 < \dots < \alpha_K < \pi/2 \end{array} \right. \quad (4)$$

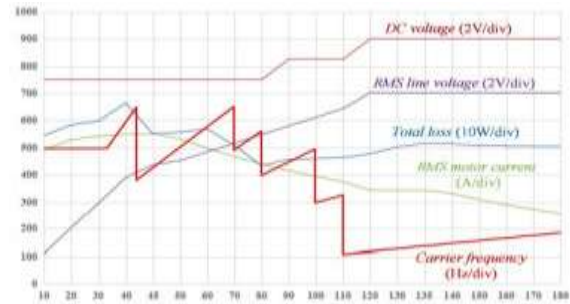

The fundamental frequency of VSI variables is shown in this diagram.

To provide optimal engine control, a hybrid PWM architecture has been implemented, where each PWM must meet the following requirements:

Limiting pinnacle current reduces IGBT current weight.

in order to avoid converter catastrophes, take into mind the limitations of exchanging frequencies and the normally modest frequency fluctuations that are characteristic of converters.

Consistent material is OK.

There must be a PWM and an FPGA capable of meeting the needs of M-edge LUTs and score-edge LUTs

III. Transitions between PWMs that are smooth and seamless.

IV. SMOOTH TRANSITION DISCUSSION:-

A. A. As the footing grows in speed, the bearer proportion drops as the expanding recurrence is bit by bit enlarged, and the contrary is true for the half-and-half PWM process. The critical shift in the transporter % will have an impact on the PWM yield voltage's exact stage management. As a consequence, a

dead time or chip advanced control mistake may easily cause the inverter's stage fluctuation between the actual yield voltage and the reference voltage. It is due of these circumstances that the footing engine current and torque stun.

B. B. \sC. Starting with general progress proposals and then going on to more technical discussions of improvements, including progress approaches and performance comparisons between a single DSP and the suggested structure, SHEPWM and CHMPW, will be provided.

C. General Rules of Smooth Transition:-

So as to retain the soundness of engine streams and torques, when travelling between different PWM balancing modes, the following angles should be regarded to keep the advancement of PWMs from easy back rates to square-wave.

Initially, endeavour to retain the key evolution, including smooth shifts of stage and plentifulness. The accuracy of the exchanging point and the control calculation are two of the most important factors in key advancement. At that time the influence of music can't be underestimated. Symphonious phases are not promised to remain uninterrupted in different forms of exchanging, on the grounds that the consonant substance is differed for each manner, and stage modifications are inevitable.

So the progress needs to retain a strategic distance from too enormous general symphonious change, all together not to generate the consonant current consequence. At long last, hysteresis must be implemented at each step so that the framework does not cycle incessantly between two unusual regulatory modes at a specified pace. A hysteresis of 0.5 Hz is used in the suggested method.

D. More Discussion on Smooth Transition:-

V. In the full speed range, the half-and-half PWM shows a few notable improvements. The primary difference comes between two CBPWMs of APWM and CSPWM, where the transporter frequencies are nearly no differentiation and the M is constant, which make it easy to complete smooth progress. The change will likewise turn out to be easy when it happens between 3-beat OSPWM and square-wave [11], for the point of the 3-beat OSPWM will drop to zero as per the increasing M, which is square-wave. Despite the advancement, the engine's flow and torque may be maintained.

VI.

VII. In any event, the primary progression and consonant impact turn out to be more vital when the advancements happen between CSPWM and OSPWM, or within OSPWMs, specifically when only a single MCU or DSP is used or SHEPWM is utilised for OSPWM.

VIII. Simulation results:

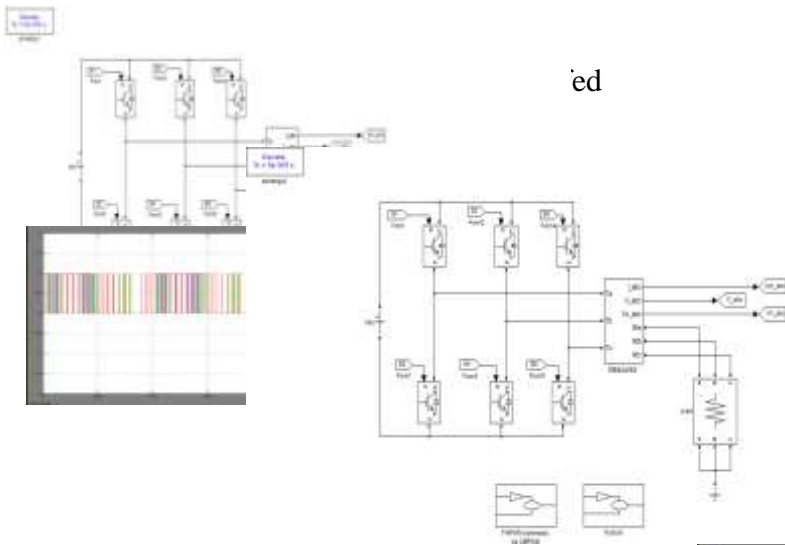

ied

(a) Pulses

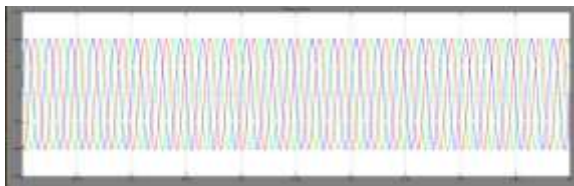

(b) Phase Currents



(a) Stator Current

(f) Torque

Fig:6 simulation results of Inverter fed Induction motor drive without load

Fig:7 simulation diagram of Voltage source inverter with R Load

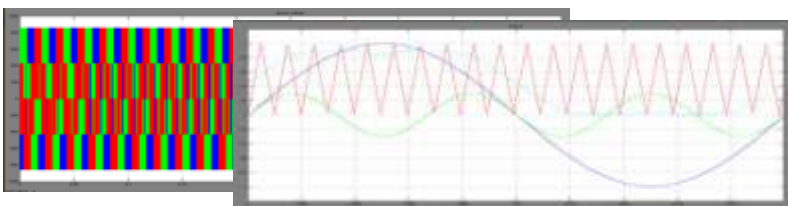

(a) Control Strategy

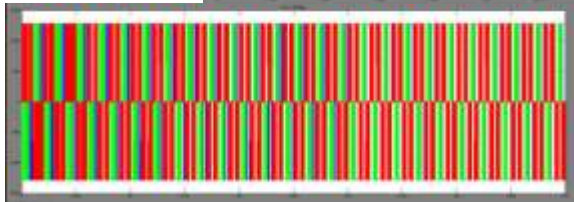

(c) Line Voltage

(d) Phase Voltages

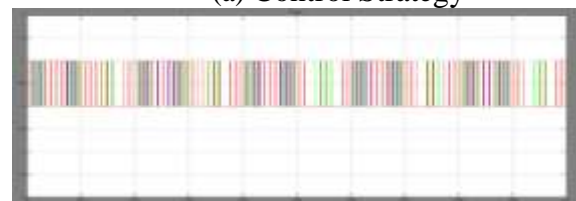

(b) Pulses

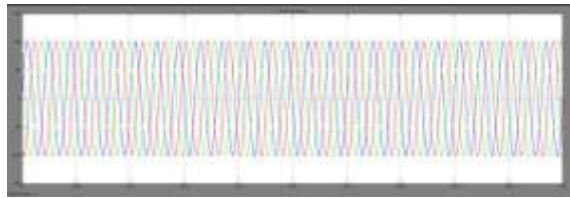

(c) Phase Currents

(a) Phase currents
(b) Line Voltages

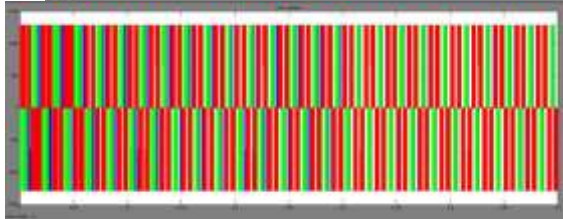
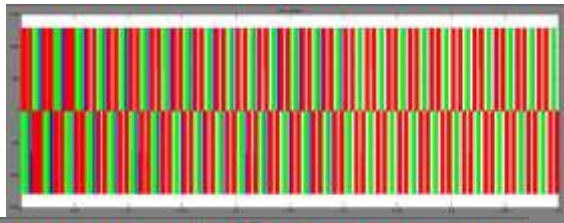

(a) Phase Voltages

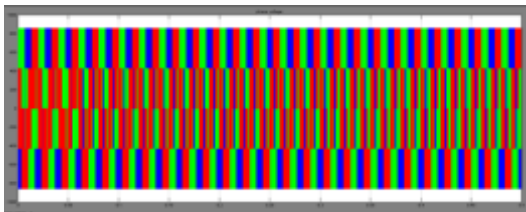

(e) Phase Voltages

Fig: 8 simulations results of Voltage source inverter with R Load

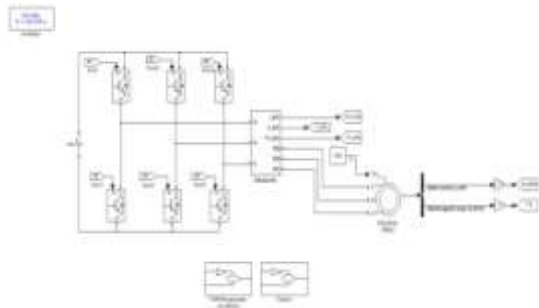
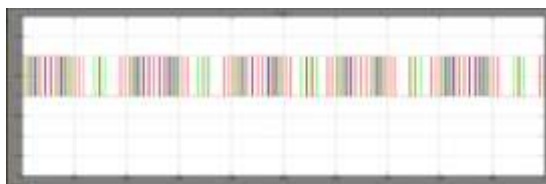
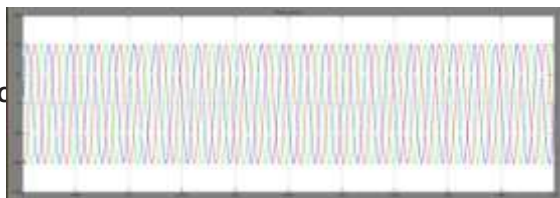

Fig: 9 simulation diagram of Inverter fed Induction motor drive with load



(a) Pulses



(c)

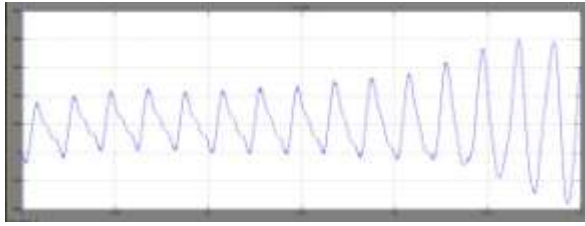

(a) Stator Current

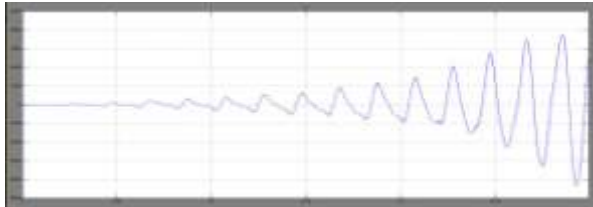

(a) Torque

Fig: 10 simulations results of Inverter fed Induction motor drive with load

Simulation results by using fuzzy logic controller:

Fuzzy rule is a type of many-regarded rationalisation in which reality assessments of components may be any bona fide number some place between the scope of 0 and 1. It is possible for reality estimates of components to be just 0 or 1 when using the Boolean technique. Fluffy foundations have been engaged to control the potential of partial truth, where reality respect may fluctuate between being fully obvious and being utterly untrue. Moreover, when semantic elements are employed, these degrees may be monitored by unique abilities.

The three variables of the FLC, the error, the change in error and the output, have seven triangle membership functions for each. Sets of fundamental fuzzies

of membership functions for the variables are as indicated in the Figs.11.

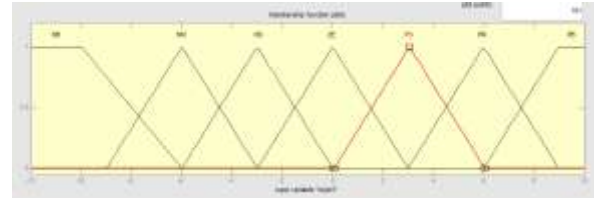

Fig 11(a) Function member ship of input1

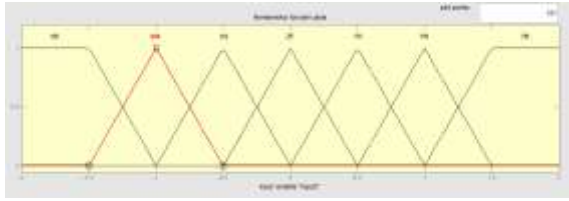

Fig 11(b) Function member ship of input2

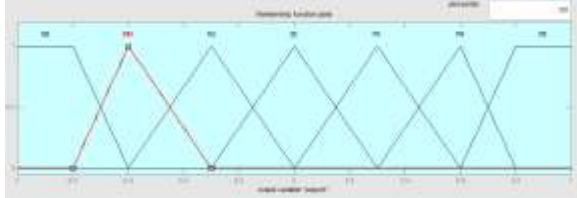
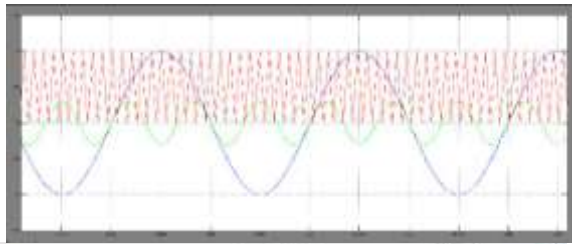

Fig 11(c) Function member ship of output



xTABLE: 1. FUZZY Rules

PB	ZE	Z E	Z E	NB	N B	NB	NB
PM	ZE	Z E	Z E	NM	N M	NM	NM
PS	ZE	Z E	Z E	NS	NS	NM	NM
ZE	NS	NS	Z E	ZE	Z E	PS	PS
NS	PM	P M	P M	NS	Z E	PS	ZE
NM	PM	P M	P M	PB	Z E	PS	ZE
NB	PB	P M	P M	PB	Z E	ZE	ZE

For each of the three factors, the semantic factors positive huge (PB), positive medium (PM), positive small (PS), zero (Z), negative little (NS), negative medium (NM), and negative large (NB) convey the fuzzy factors' significance. A lead in the govern base may be conveyed in the shape: If both (e) and (de) are NB, then (album is Z). The tenets are established in light of the framework's information and operation. The administrate base modifies the obligation cycle for the PWM of the inverter as per the alterations in the contribution of the FLC. The amount of principles may be specified aswanted. The quantities of guidelines are 49 for the seven enrollment elements of the blunder and the adjustment in mistake (contributions of the FLC).

Fig: 12 Simulation diagram of Voltage source inverter with R Load

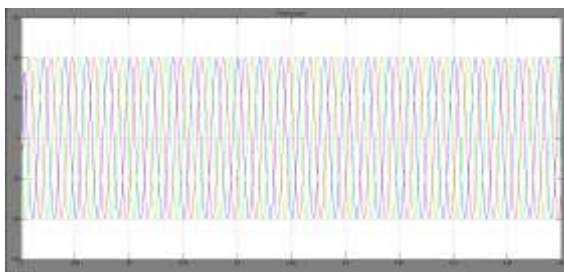

e/ Δe	PB	P M	PS	ZE	NS	NM	NB
-------	----	--------	----	----	----	----	----

(a)Control Strategy

(a)Pulse

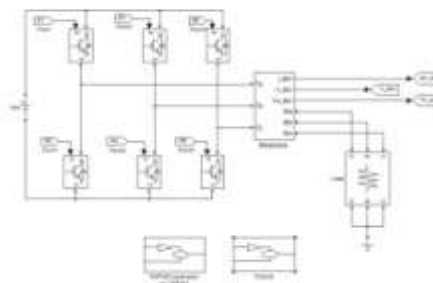

(a) Phase current

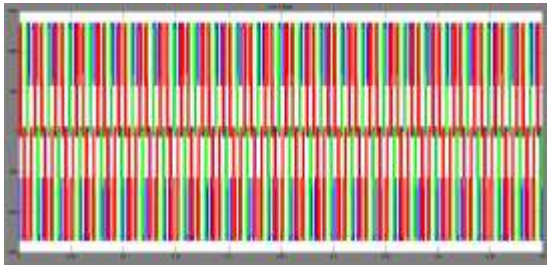

(a)

Pulse

(a) Line voltage

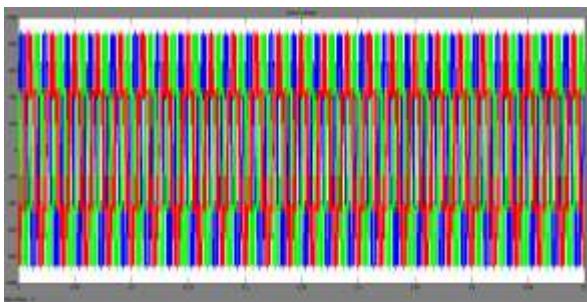
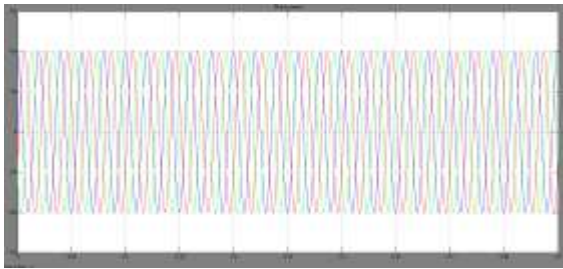

(a) Phase voltage

Fig: 13 Simulation results of Voltage source inverter with R Load

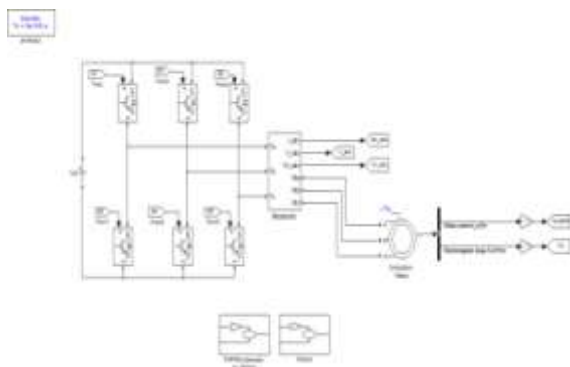
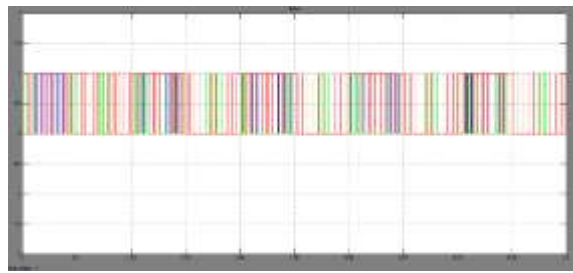
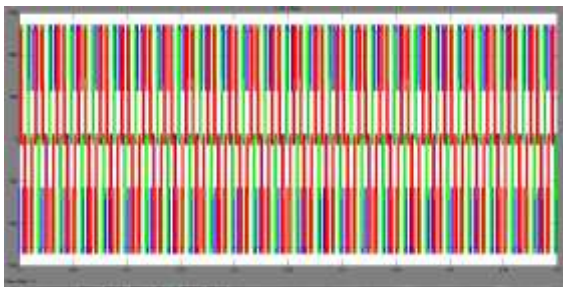
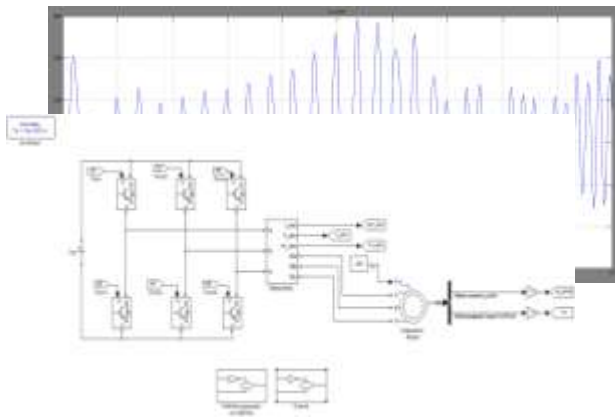

Fig: 14 simulation diagram of Inverter fed Induction motor drive without load torque



(b) Phase current



(c) Line voltage

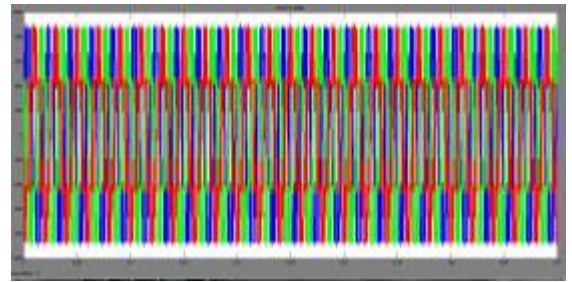

(d) Phase voltages

(e) Stator current

(f) Torque

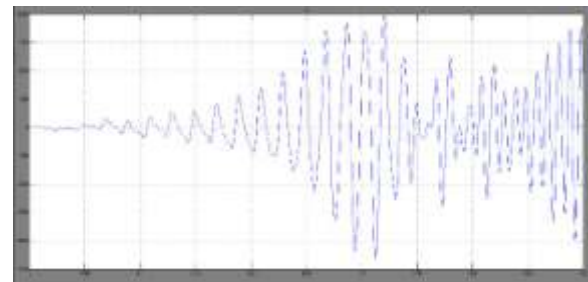
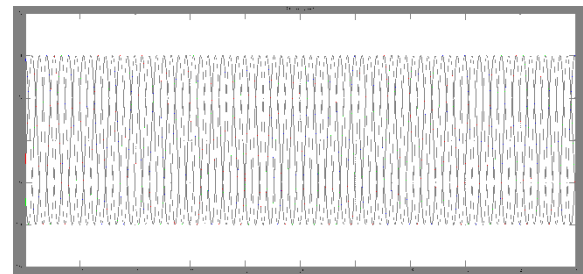
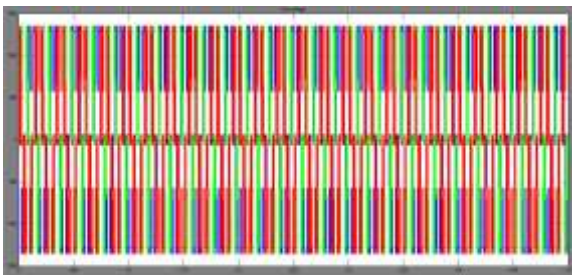

Fig: 15 simulation results of Inverter fed Induction motor drive without load torque

Fig: 16 simulation diagram of Inverter fed Induction motor drive with load torque

(a) Pulse



(b) Phase current

(c) Line voltages

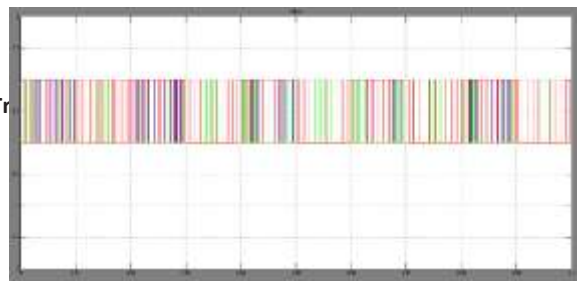

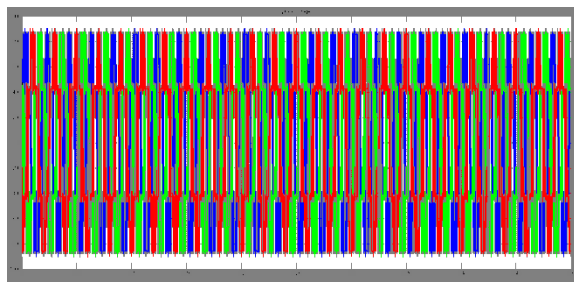

(d) phase voltages

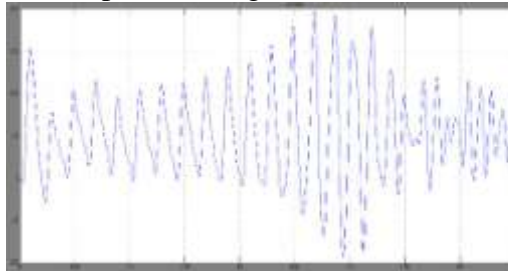

(e) Stator current

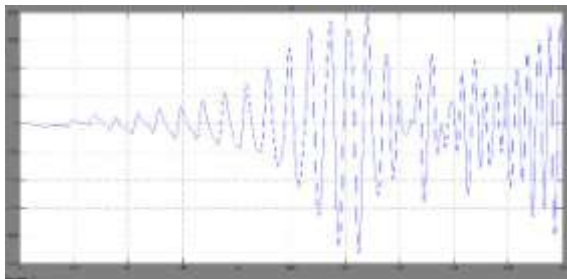

(f) Torque

Fig: 17 simulation result of Inverter fed Induction motor drive with load torque

VI. CONCLUSION:-

The hybrid PWM subject for electrical traction motor control is simplified in this research using a Fuzzy Logic Controller system and existing approach. By totally utilising the points of interest and assets of each processor, high-precision hybrid PWMs square measure enforced while fulfilling the multi-rate and multi-task process of the traction management. The implementation strategies of the bestowed hybrid PWM technique, wherever asynchronous and synchronous THIPWM4, CHMPWMs square measure used for transiting from low-speed to square-wave, square measure mentioned intimately, together with algorithms

between the 2 processors, swish transition, etc.. by using the fuzzy logic controller and desining in MATLAB/SIMULINK the THD values are reduced compared to the existing results PWM creation based on simulation findin Low total harmonics supported by a horribly low switch frequency have been obtained with great precision and the feature of low losses, allowing the control to function better and the system's reliability to grow.

REFERENCES:-

Among them: De Doncker, Rik, Duco WJ Pulle, and André Veltman. Analyzing, modelling, and controlling advanced electrical drives. Springer Science & Business Media, 2010.

[1] A Space Vector Modulator for the High-Switching Frequency Control of Three-Level SiC Inverters, by J. Holtz, M. Höltingen, and J. O. Kraß, IEEE Trans. Power Electronics vol. 29, no. 5, May 2014, p.

(2) "Evaluation of Switching Performance of SiC Devices in PWM Inverter-Fed Induction Motor Drives," IEEE Trans. Power Electronics, vol. 30, no. 10, pp. 5701-5711, Oct. 2015. Z. Zhang, F. Wang, L. M. Tolbert, B. J. Blalock and D. J. Costinett

[2] In conjunction with reversible variable speed AC drives, A. Schonung and H. Stemmler "Static Frequency Changers with Subharmonic Control in 1964, pp. 555-557", Brown Boveri Rev.

[3] [3] van der Broeck HW, Skudelny H-C, Stanke GV, "Analysis and realisation of a pulse width modulator based on voltage space vectors," IEEE Trans. Industry Applications, vol. 24, no. 1, pp.142-150, 1988. J. Holtz, "Electronic power conversion using pulse width modulation," Proc. IEEE, vol. 82, no. 8, Aug. 1994, pp. 1194-1214.

[5] [4] Holmes D G, Lipo T A. Pulse width modulation for power converters: concepts and practise. John Wiley & Sons, 2003.

Ayyanar and Ayyanan, "Space-Vector-Based Hybrid Pulse width modulation techniques for reduced harmonic distortion," IEEE Trans. Power Electronics, vol. 25, no. 3, March 2010, pp. 760-774.

[6] Induction motor drives using an advanced hybrid PWM technique to reduce torque ripple are discussed in IEEE Trans on Industrial Electronics (vol 57 no 6, june 2010), by K Basu and J. S. S. Prasad, G. Narayanan, H. K. Krishnamurthy and R. Ayyanar.