

## A 41% bandwidth microstrip patch antenna

Mehmet Yusuf Imeci<sup>1</sup>, S. Taha Imeci<sup>2</sup>, Ramazan Daşbaşı<sup>3</sup>

<sup>1</sup> International University of Sarajevo, Department of Electrical Engineering, Bosnia and Herzegovina

<sup>2</sup> Fatih Sultan Mehmet Vakıf University, Department of Electrical and Electronics Engineering, Fatih-İstanbul, Türkiye

<sup>3</sup> Yıldız Technical University, Electronics and Communication Engineering, Türkiye

\*Corresponding author E-mail: [mehmedyusufimeci@gmail.com](mailto:mehmedyusufimeci@gmail.com)

Received: Jul. 14, 2022  
Revised: Feb. 20, 2023  
Accepted: Feb. 27, 2023  
Online: Mar. 2, 2023

### Abstract

This work contains a wideband DS (defected-ground-structure) microstrip patch antenna. Initially, the intention of this work was based on realizing a sub-6 GHz 5G microstrip patch antenna, but through many experimentations, we inadvertently stumbled upon a different kind of microstrip patch antenna, namely, an antenna with a substantially wide band. The numeric values of the variables/parameters of this compact, wide-band, microstrip patch antenna, which has a proudly high fabrication tolerance, are as follows:  $S_{11} = -10.09 \text{ dB}$ ,  $frequency = 8.7 \text{ GHz}$ ,  $\epsilon_{\theta} = 2.67 \text{ dB}$ ,  $\epsilon_{\phi} = -2.3 \text{ dB}$ . The bandwidth reaches approximately 6.6 GHz to 10.2 GHz, hence giving this particular design's bandwidth a proud 41% value.

The inspiration for this work came from [11], which posed two symmetrical antennas opposite from one another, whereas this work has produced a singular antenna, with a more circular center, and with other many modified traits.

© The Author 2023.  
Published by ARDA.

**Keywords:** DGS, microstrip, Patch, Antenna, Wideband, Sub-6 GHz, 5G

### 1. Introduction

Printed patch radiators didn't really shine in the world of technology until the 1970s when the wireless data transfer methods in communication systems practically skyrocketed. Even though these types of antennas are small and fairly cheaply produced, they still hold the capability of being integrated with RF circuits [1]. For the past about 10 years or so, dielectric resonators (DR) have quite increasing popularity owing to their practicality [2]. As you, the typical reader of this type of work would probably know, 5G stands for fifth-generation mobile network. In a broad sense, explaining it could simply boil down to how its main purpose, is to connect everything together, as far as in the realm of communication systems. [3]. Millimeter-wave (mm-Wave) bands coupled with 5G technology, allow data to be transferred in substantially greater amounts [4]. Technologies such as say, today's cell phones, especially ones that operate below 3 GHz, are used quite a lot in the sub-6 GHz range [5]. Dual-band antennas are a lot of times constructed by choosing different parts in different band values, and adding them to construct a new part [6]. Sub-6 GHz technology with respect to mm-waves not only surpasses physical range, thus covering greater distances, it also poses as a cheaper alternative with a wider bandwidth, which brings a high amount of data transferring capability [7]. High-speed and low-latency data transfer has become increasingly important as wireless systems got increasingly sophisticated in a relatively short span of time [8]. Studies indicate the details on how the antenna's properties conform to various stub parameters [9]. All in all, microstrip patch antennas are a great companion to be coupled with 5G applications [10]. Lots of smartphones in these past years that are to be integrated with 5G, have been posed with wideband antennas that are not only as high as 6 GHz but are also as less efficient as 50% [11]. The absolute explosion of the Internet of Things (IoT) and various other wireless technologies in our current era of technological developments, has made it somewhat crucial for newer and better

This work is licensed under a [Creative Commons Attribution License](https://creativecommons.org/licenses/by/4.0/) (https://creativecommons.org/licenses/by/4.0/) that allows others to share and adapt the material for any purpose (even commercially), in any medium with an acknowledgement of the work's authorship and initial publication in this journal.



breakthroughs and technologies to emerge for better inner adaptability, and 5G is one such example. [12]. There isn't even a need to state the obvious of the absolutely crucial role of the internet in data transmission in high quantities [13]. Sub-6 GHz technology surely helps in this high quantity *and* high-speed data transfer [14]. Omni-directional antennas aren't particularly the highest-range antennas [15]. A patch antenna is basically a radio antenna that you can easily just mount to a surface. [16]. The microstrip patch antenna finds itself a role in all ranges of mobile communication systems [17]. (5G) technology is definitely on the rise where communication systems are concerned, and this explosive widening of its use happens to be occurring in many nations worldwide. [18]. To fully realize and reap the benefits of 5G technology, small and highly efficient antennas are a must [19]. 5G has substantially reduced latency and many many other benefits with respect to 4G. Therefore, 5G is expected to rule the domain it's present in, for the foreseeable future in our current era where technological developments are at an all-time rise [20].

## 2. Research method

All research for this publication has been made possible with use of *Sonnet Software*, which is a simulation tool that is widely popular in microwave circuit analyses.

As you can see from the following three figures, (figures 1-3), our microstrip patch antenna design consists mainly of rectangular shapes, with the only exception of the center, which is basically a circle. The metal parts of the design are obviously much smaller than the whole design, as the dimensions are about 1.5 to 4.5 centimeters, while the whole box size is about 24 to 8.5 centimeters. The thickness of the whole design, as it may appear from the 3D view below, looks quite massive, but we remind you that that's just a close-up zoomed-in view of the design, and in reality, with all the layers combined, the whole design is only as thick as about 3 centimeters. As it appears from the simulation results from Sonnet Software regarding our design (figure 4), our band range starts from about 6.5 GHz, and goes all the way up to a little over 10.2 GHz, and thus, corresponds to a bandwidth value of 41%. It may also be apparent that the lowest point of  $S_{11}$  appears to be just a little below -25 dB.

## 3. Results and discussion

The dimensions and shape of this antenna design is shown in Figure 1, Figure 2, and Figure 3.

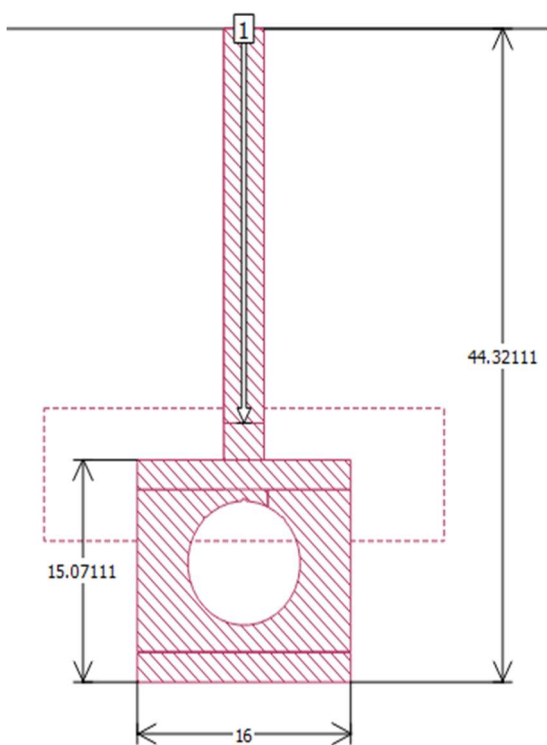

Figure 1. The top view with dimensions in mm (box not included)

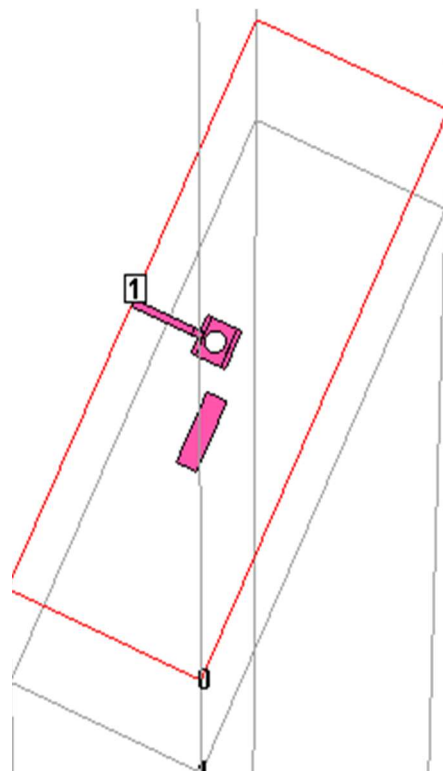

Figure 2. The 3D view (main part)

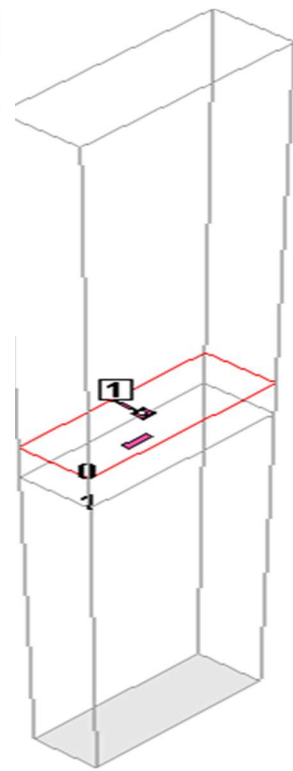

Figure 3. 3D view (complete)

Patch antenna main design results of the S-parameters are shown graphically in Figure 4.

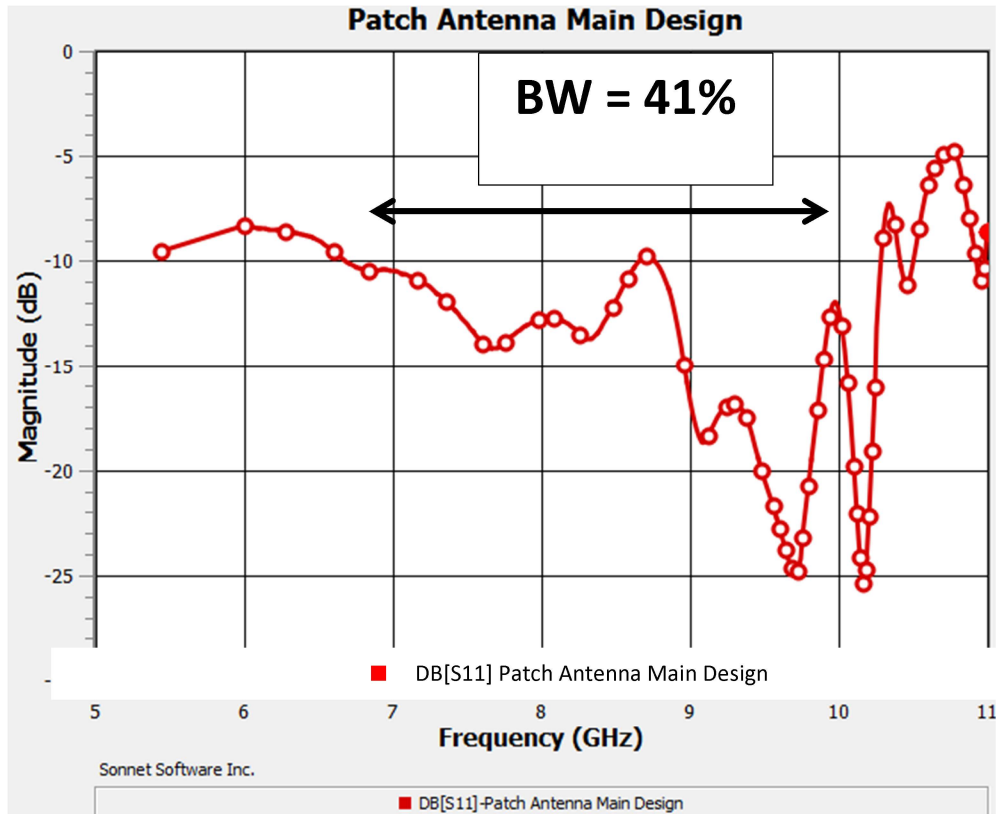

Figure 4. The S-parameters graph for the main design

One can observe below in (table 1) that when we changed the dielectric constant values starting from 4.3, and going all the way up to 4.5, our frequency and gain results practically didn't change. The closest result to the original design came when the dielectric constant value was 4.5 (4.4 was the original value).

Table 1. Changing the dielectric constants (main design values in **bold**)

Dielectric constant ( $\epsilon_r$ )	Magnitude (dB)			Frequency (GHz)
	$S_{11}$	$\epsilon_\theta$	$\epsilon_\phi$	
4.3	-13.01	2.38	-2.55	8.62
4.35	-13.45	2.35	-2.52	8.58
<b>4.4</b>	<b>-9.79</b>	<b>2.67</b>	<b>-2.3</b>	<b>8.7</b>
4.45	-13.59	2.38	-2.51	8.54
4.5	-12.06	2.51	-2.52	8.64

As it can be seen in the following (table 2) that when we changed the dielectric thicknesses starting from 1.5 mm, and going all the way up to 1.6mm, our frequency and gain results practically didn't change. The closest result to the original design came when the dielectric thickness value was 1.57 mm (1.55 mm was the original value).

Table 2. Changing the dielectric thicknesses (main design values in **bold**)

Dielectric thickness	Magnitude (dB)			Frequency (GHz)
	$S_{11}$	$\epsilon_\theta$	$\epsilon_\phi$	
1.5	-13.56	2.45	-2.41	8.62
1.53	-12.96	2.47	-2.5	8.62
<b>1.55</b>	<b>-9.79</b>	<b>2.67</b>	<b>-2.3</b>	<b>8.7</b>
1.57	-11.64	2.47	-2.56	8.68
1.6	-11.37	2.44	-2.63	8.66

When we consider the following results (table 3), when we changed the length of the center in the y-axis starting from 14.5 mm, and going all the way up to 15.5 mm, our frequency and gain results again practically didn't change. The closest result to the original design came when the length of the center in the y-axis was 14.75 mm (15.07 mm was the original value).

Table 3. Changing the length of the center in the y-axis (main design values in **bold**)

The length of the center in the y-axis	Magnitude (dB)			Frequency (GHz)
	$S_{11}$	$\epsilon_{\theta}$	$\epsilon_{\phi}$	
14.5	-11.57	2.66	-2.3	8.54
14.75	-10.38	2.72	-2.34	8.64
<b>15.07</b>	<b>-9.79</b>	<b>2.67</b>	<b>-2.3</b>	<b>8.7</b>
15.25	-11.43	2.63	-2.19	8.54
15.5	-11.9	2.57	-2.04	8.5

As it's apparent from the table below (table 4), when we changed the length of the center in the x-axis starting from 15 mm, and going all the way up to 17 mm, our frequency and gain results once again practically didn't change. The closest result to the original design came when the length of the center in the x-axis was 15 mm (16 mm was the original value).

Table 4. Changing the length of the center in the x-axis (main design values in **bold**)

The length of the center in the x-axis	Magnitude (dB)			Frequency (GHz)
	$S_{11}$	$\epsilon_{\theta}$	$\epsilon_{\phi}$	
15	-12.1	2.5	-2.53	8.66
15.5	-12.11	2.57	-2.42	8.58
<b>16</b>	<b>-9.79</b>	<b>2.67</b>	<b>-2.3</b>	<b>8.7</b>
16.5	-10.91	2.65	-1.9	8.48
17	-10.29	2.58	-1.4	8.38

Please refer to the below results (table 5), to see that when we changed the length of the ground in the x-axis starting from 29 mm, and going all the way up to 31 mm, our frequency and gain results once again practically didn't change, but at 29.5 mm, we had a weird spike in frequency (from 8.68 to 8.74), but the closest result to the original design came when the length of the ground in the x-axis was 30.5 mm and at 31 mm.

At 30.5 and 31 mm, the frequencies were the same and 8.68 GHz, which is the same exact frequency with the original design (30 mm was the original value).

Table 5. Changing the length of the ground in the x-axis (main design values in **bold**)

The length of the ground in the x-axis	Magnitude (dB)			Frequency (GHz)
	$S_{11}$	$\epsilon_{\theta}$	$\epsilon_{\phi}$	
29	-11.63	2.47	-2.4	8.62
29.5	-11.22	2.45	-2.41	8.74
<b>30</b>	<b>-10.09</b>	<b>2.67</b>	<b>-2.28</b>	<b>8.68</b>
30.5	-12.41	2.48	-2.61	<b>8.68</b>
31	-14.89	2.45	-2.7	<b>8.68</b>

We can refer to the below figure (figure 5) to view the current distribution. The darkest blue, illustrating zero current being distributed, while the darkest red oppositely illustrating the highest amount of current being distributed, note that the colors cause the current distribution to be clearly and vividly represented.

This current distribution is specifically illustrating the distribution at 8.7 GHz, which is the original frequency of the design.

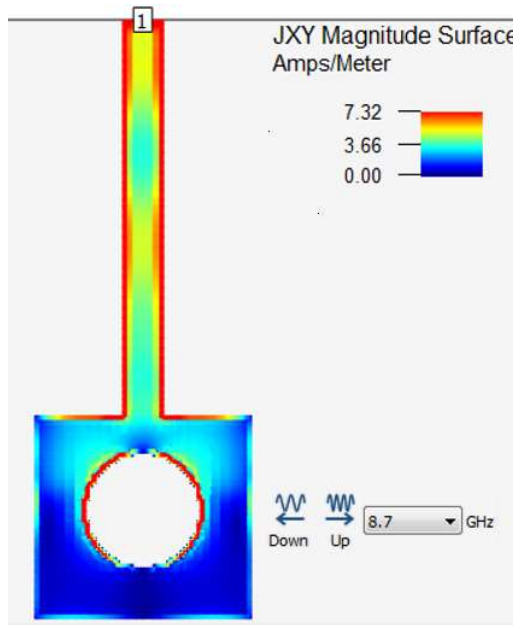

Figure 5. The current distribution

Note that in the following two figures (figures 6-7), the gain results of the 8.7 GHz main design are presented. And the main results are  $\epsilon_{\theta} = 2.67 \text{ dB}$  (figure 6), and  $\epsilon_{\phi} = -2.3 \text{ dB}$  (figure 7).

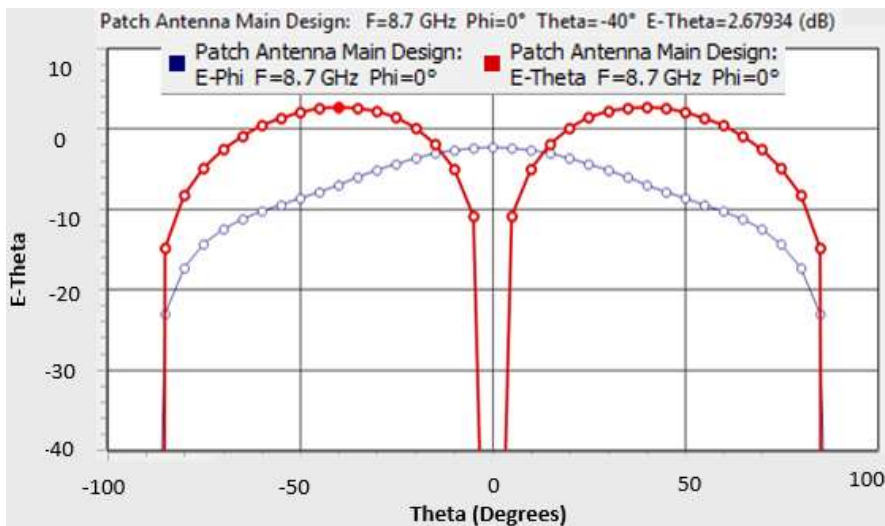

Figure 6. The phase angles graph (E-Theta)

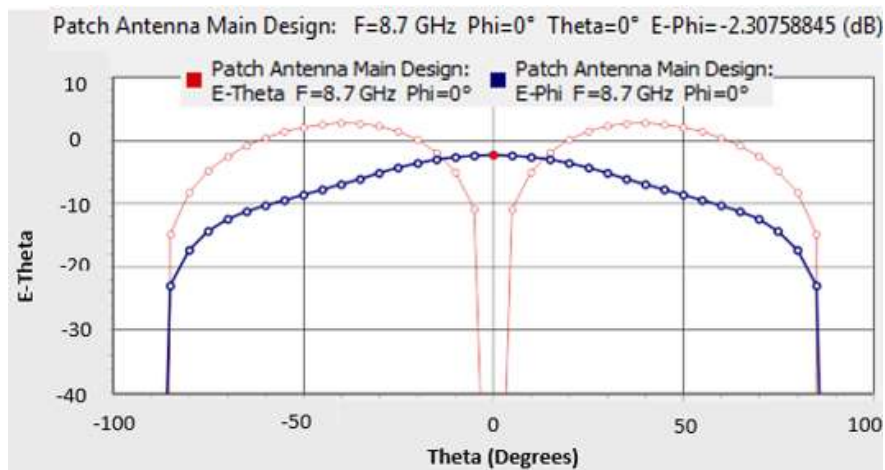

Figure 7. The phase angles graph (E-Phi)

#### 4. Conclusions

As it may be obvious from previous reading of this current work, our antenna design with the given characteristics ( $S_{11} = -10.09 \text{ dB}$ ,  $\text{frequency} = 8.7 \text{ GHz}$ ,  $\epsilon_{\theta} = 2.67 \text{ dB}$ ,  $\epsilon_{\phi} = -2.3 \text{ dB}$ ), poses a unique and valuable presence in communication systems, at the current era the world resides in. Even though the initial intentions of this work were to realize a completely different type of antenna with a fairly dissimilar category (a sub-6 GHz 5G microstrip patch antenna), the beauty of experimentation and the surprises it may offer (like in this case), sometimes delivers a completely different but no less important type of separate technology. Parametric studies, where the fabrication tolerances are obviously present, also supports the tangible value and practicality of this 41% bandwidth design of a miniature beast, that despite its puny size, has a pretty far reach (high frequency range).

#### Declaration of competing interest

The authors declare that they haven't any known financial or non-financial competing interests in any material discussed in this paper.

#### Funding information

No funding was received from any financial organization to conduct this research.

#### References

- [1] A. Kapoor, R. Mishra, and P. Kumar, "Wideband miniaturized patch radiator for Sub-6 GHz 5G devices," *Helvion*, vol. 7, no. 9, p. e07931, 2021.
- [2] J. Iqbal, U. Illahi, M. N. M. Yasin, M. A. Albreem, and M. F. Akbar, "Bandwidth enhancement by using parasitic patch on dielectric resonator antenna for sub-6 GHz 5G NR bands application," *Alex. Eng. J.*, vol. 61, no. 6, pp. 5021–5032, 2022.
- [3] A. Al-Gburi, "Wideband microstrip patch antenna for sub 6 GHz and 5G applications," *Prz. Elektrotech.*, vol. 1, no. 11, pp. 28–31, 2021.
- [4] D. N. Gençođlan and Ş. Çolak, "Investigation of origami inspired sub-6 GHz accordion monopole antenna for 5G applications," *Sak. Univ. J. Sci.*, vol. 25, no. 4, pp. 974–983, 2021.
- [5] M. Yerlikaya, S. S. Gültekin, and D. Uzer, "A novel design of a compact wideband patch antenna for sub-6 GHz fifth-generation mobile systems," *International Advanced Researches and Engineering Journal*, vol. 4, no. 2, pp. 129–133, 2020.
- [6] W. Sun, Y. Li, L. Chang, H. Li, X. Qin, and H. Wang, "Dual-band dual-polarized microstrip antenna array using double-layer gridded patches for 5G millimeter-wave applications," *IEEE Trans. Antennas Propag.*, vol. 69, no. 10, pp. 6489–6499, 2021.
- [7] I. Ahmad et al., "Design and experimental analysis of multiband compound reconfigurable 5G antenna for sub-6 GHz wireless applications," *Wirel. Commun. Mob. Comput.*, vol. 2021, pp. 1–14, 2021.
- [8] B. Huang, M. Li, W. Lin, J. Zhang, G. Zhang, and F. Wu, "A compact slotted patch hybrid-mode antenna for sub-6 GHz communication," *Int. J. Antennas Propag.*, vol. 2020, pp. 1–8, 2020.
- [9] B. G. Hakanoglu, B. Koc, O. Sen, H. Yalduz, and M. Turkmen, "Stub loaded patch antenna and a novel method for miniaturization at sub 6 GHz 5G and WI-fi frequencies," *Adv. Electr. Comput. Eng.*, vol. 21, no. 2, pp. 23–32, 2021.
- [10] T. O. Olawoye and P. Kumar, "A high gain antenna with DGS for sub-6 GHz 5G communications," *Adv. electromagn.*, vol. 11, no. 1, pp. 41–50, 2022.
- [11] S. S. Al-Bawri et al., "Broadband sub-6GHz slot-based MIMO antenna for 5G NR Bands mobile applications," *J. Phys. Conf. Ser.*, vol. 1962, no. 1, p. 012038, 2021.
- [12] M. Alibakhshikenari et al., "Dual-polarized highly folded bowtie antenna with slotted self-grounded structure for sub-6 GHz 5G applications," *IEEE Trans. Antennas Propag.*, vol. 70, no. 4, pp. 3028–3033, 2022.

- 
- [13] R. Mishra, R. Dandotia, R. Mishra, P. Kuchhal, and R. Pachauri, "SRR slotted multiband antenna in sub 6-GHz for futuristic communication," *EAI Endorsed Trans. Energy Web*, p. 165997, 2018.
- [14] P. Jha, S. Singh, and R. L. Yadava, "Wideband sub-6 GHz micro-strip antenna: Design and fabrication," in *Advances in Smart Communication and Imaging Systems*, Singapore: Springer Singapore, 2021, pp. 109–115.
- [15] M. Farasat, D. N. Thalakituna, Z. Hu, and Y. Yang, "A review on 5G sub-6 GHz base station antenna design challenges," *Electronics (Basel)*, vol. 10, no. 16, p. 2000, 2021.
- [16] T. Aathmanesan, "Novel slotted hexagonal patch antenna for Sub-6 GHz 5g wireless applications."
- [17] A. Kapoor, R. Mishra, and P. Kumar, "Compact wideband-printed antenna for sub-6 GHz fifth-generation applications," *Int. j. smart sens. intell. syst.*, vol. 13, no. 1, pp. 1–10, 2020.
- [18] P. Dwivedi and D. Sen, "Micro-strip antenna design for 5G sub 6 GHz and WI-Fi applications," *Int. J. Sci. Res. (Raipur)*.
- [19] B. Tütüncü and M. Kösem, "Substrate analysis on the design of wide-band antenna for sub-6 GHz 5G communication," *Wirel. Pers. Commun.*, pp. 1–13, 2022.
- [20] Darwin and Sampath, "Sub-6 GHz band massive MIMO antenna system for variable deployment scenarios in 5G base stations," *Research Square*, 2021.