

Study and Design of a WLAN WSN Wake-Up Receiver

Mariem Bouraoui

Department of Electrical Engineering, College of Engineering, Prince Sattam Bin Abdulaziz University, Al-Kharj 11942, Saudi Arabia | Systems Integration and Emerging Energies Laboratory, Electrical Engineering Department, National Engineers School of Sfax, University of Sfax, 3038 Sfax, Tunisia
m.bouraoui@psau.edu.sa (corresponding author)

Imen Barraaj

Department of Computer Engineering, College of Computer Engineering and Sciences, Prince Sattam Bin Abdulaziz University, Al-Kharj 11942, Saudi Arabia | Systems Integration and Emerging Energies Laboratory, Electrical Engineering Department, National Engineers School of Sfax, University of Sfax, 3038 Sfax, Tunisia
i.barraaj@psau.edu.sa

Mohamed Masmoudi

Systems Integration and Emerging Energies Laboratory, Electrical Engineering Department, National Engineers School of Sfax, University of Sfax, 3038 Sfax, Tunisia
mohamed.masmoudi@enis.tn

Received: 15 April 2025 | Revised: 25 May 2025 and 6 June 2025 | Accepted: 8 June 2025

Licensed under a CC-BY 4.0 license | Copyright (c) by the authors | DOI: <https://doi.org/10.48084/etasr.11518>

ABSTRACT

Research on wake-up receivers is gaining momentum due to the growing demand for this compact yet crucial component in advanced technological systems that rely on radio-based communication. Wake-up receivers play a key role in minimizing the activity of the main radio, thereby significantly reducing energy consumption, and extending the overall system lifetime. This paper provides an overview of the design considerations and challenges associated with wake-up receivers, along with a comparison of several existing architectures. Additionally, a Wireless Local Area Network (WLAN) wake-up receiver is validated using Advanced Design System (ADS) software. A performance comparison between Amplitude Modulation (AM) and Differential Quadrature Phase Shift Keying (DQPSK) modulation schemes is also presented.

Keywords-WSN; WLAN; wake-up receiver; envelope detector; AM; DQPSK; modulation

I. INTRODUCTION

A Wireless Sensor Network (WSN) consists of battery-powered sensor nodes distributed across a specific application area. Figure 1 illustrates the block diagram of a typical sensor node. As the world transitions into the era of the Internet of Everything (IoE), the coverage areas of WSNs are expanding, and the number of deployed sensor nodes in each network is growing exponentially. It was projected that over 50 billion devices would be connected to the Internet by 2020 [1]. Given the rapid increase in sensor node deployment, WSNs face a critical challenge: reduced system lifetime due to rising energy consumption, particularly from the main radio receiver, and the limited capacity of battery-powered sources. Consequently, the reduction of overall energy usage has become a fundamental requirement for the sustainability and effectiveness of future WSNs.

A common approach to reducing the electrical energy demand of a WSN is the implementation of a subsidiary receiver known as a wake-up receiver. This type of receiver supports the main radio receiver in monitoring its communication channel. As illustrated in Figure 2, when a wake-up receiver detects a wake-up message in the channel, it activates the primary radio. Otherwise, the main receiver remains inactive to minimize the enormous energy consumption associated with idling. As it is evident, during idling, the overall energy consumption of a WSN is mainly defined by the energy consumption of the wake-up receiver. Therefore, the wake-up receiver is required to achieve a minimum energy budget, generally at a level of 10^{-3} of the primary receiver's energy consumption. Recent research indicates that the implementation of low-power wake-up receivers in a WSN, when properly integrated at the Medium Access Control (MAC) level, can achieve an energy saving

factor of over 30 compared to conventional duty-cycled WSNs [2-4].

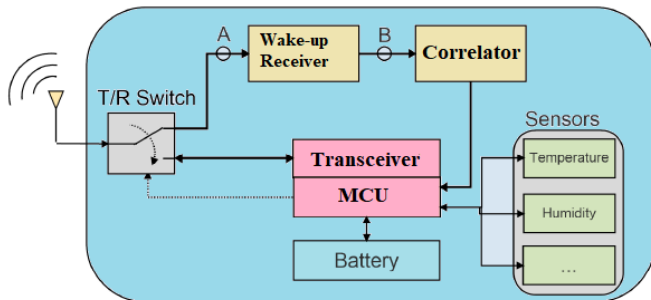

Fig. 1. Block diagram of a sensor node.

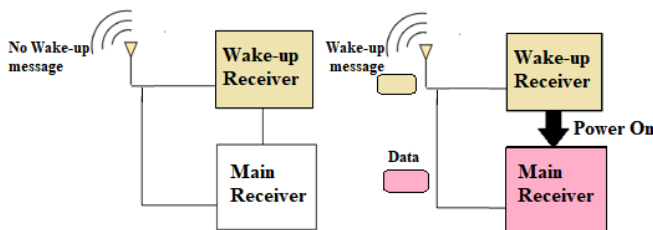

Fig. 2. A wireless communication schema using a wake-up receiver.

II. BASIC WAKE-UP RECEIVER ARCHITECTURES

In the relevant literature, there are three prevalent wake-up receiver architectures. The first one is the direct demodulation architecture, in which the signal undergoes passive or active RF amplification and filtering and then passes to an envelope detector for demodulation to Baseband (BB).

The second architecture is the transmitted local oscillator system, which uses the same general architecture as the direct demodulation architecture but is used for signals that include a transmitted tone. Through the nonlinear action of the envelope detector, this tone enables down-conversion of the signal to an Intermediate Frequency (IF) rather than BB. The third architecture is the more conventional heterodyne architecture, which employs on-chip local oscillators for down conversion prior to demodulation.

The first two architectures are typically employed for low-power applications, often at the expense of some degree of resistance to interference. In contrast, on-chip local oscillator architectures tend to consume much more power but offer enhanced resilience. Figures 3(a), 3(b), and 3(c) illustrate the direct demodulation, the transmitted local oscillator, and the on-chip local oscillator architectures, respectively. These architectures are of low complexity and are gaining popularity in wake-up receivers. Moreover, Table I presents a comparison between some recent wake-up receiver architectures.

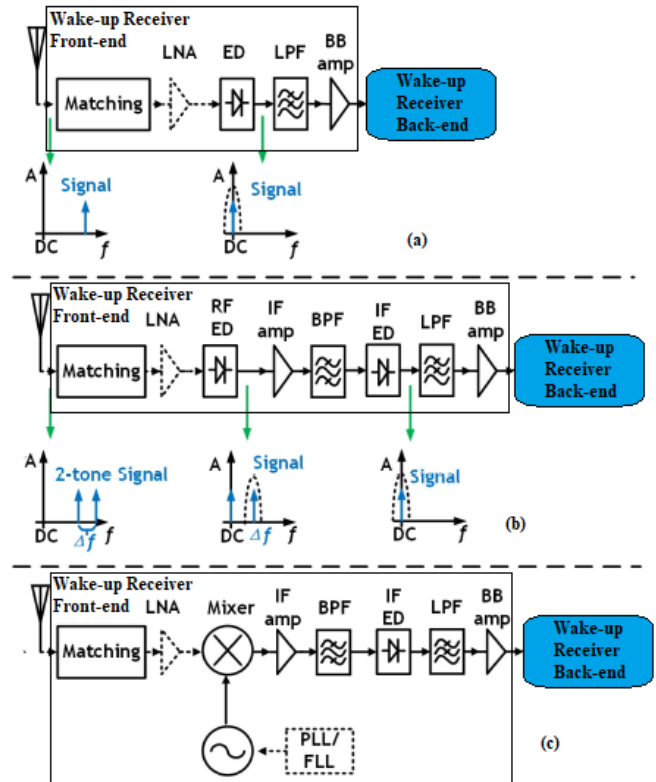

Fig. 3. (a) Direct demodulation wake-up receiver architecture, (b) transmitted local oscillator wake-up receiver architecture. (c) on-chip local oscillator wake-up receiver architecture.

TABLE I. COMPARISON OF RECENT WAKE-UP RECEIVER ARCHITECTURES

Reference	Architecture type	Technology	Power	Sensitivity (dBm)	Frequency
[5]	On-chip local oscillator	40 nm CMOS	578 μ W	-91.5	2.4 GHz
[6]	Direct demodulation	Off-the-shelf	1.38 mW	-90	868 MHz
[7]	Direct demodulation	180 nm CMOS	193 nW	-84.5	402 MHz
[8]	Transmitted local oscillator	65 nm CMOS	19 μ W	-63.6	915MHz

III. WLAN WAKE-UP RECEIVER SYSTEM

The most utilized band in the literature for the construction of wake-up receivers is 868 MHz [6]. The advantage of this band, in addition to registering in the Zigbee standards, is that it is part of the Industrial Scientific Medical (ISM) band. Using this band relaxes the limits on the communication protocol. However, wake-up receivers operating at 868 MHz are not compatible with other network types, such as Ultra-Wideband

(UWB), Wireless Personal Area Networks (WPANs), and Body Area Networks (BANs).

The objective of this study is to design a Wireless Local Area Network (WLAN) wake-up receiver. We will focus on the results at 5.2 GHz, since the ISM band specification for the IEEE 802.11a in the WLAN standard was adopted for the carrier frequency 5.2 GHz. Due to the necessity for enhanced transmission rates, 802.11b with 11 Mbit/s is clearly inferior to 802.11a, which is a modification to the IEEE 802.11 protocol

that adds a higher data rate of up to 54 Mbit/s utilizing the 5.2 GHz band [9, 10].

There is a broad spectrum of applications for WLANs in the real world. They are frequently utilized to augment existing wired networks rather than to entirely replace them. Figure 4 presents a selection of the applications that are enabled by the capabilities and adaptability of WLAN technology, including healthcare, conducting everyday business, network management in older buildings and dynamic environments.

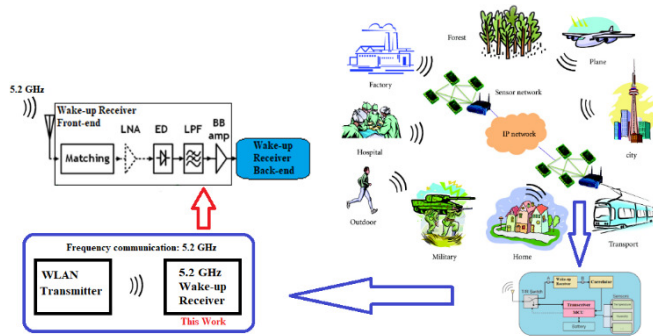

Fig. 4. WLAN wake-up receiver system applications.

A. Wake-up Receiver Advanced Design System Validation

In this work, we have chosen the direct demodulation wake-up receiver architecture due to its simplicity. This architecture directly demodulates the incident RF signal without prior down conversion to IF or BB. An On-Off Keying (OOK) modulated RF signal passes through a matching network and is filtered before the envelope detector to reduce the total noise rectified by the detector. The envelope detector output is typically weak and requires a Baseband Amplifier (BBA) that amplifies the signal prior to digitization. A digital correlator follows the digitizer to compare the signal against reference codes and determine if the input matches a wake-up signal. Figure 5 illustrates the implemented design using Advanced Design System (ADS). The Band-Pass Filter (BPF), the Low-Noise Amplifier (LNA), the Low-Pass Filter (LPF), and the BBA are ADS library components.

The circuit block requirements for the wake-up receiver front end are presented in Table II. These values have been selected based on state-of-the-art designs. Since the goal is to implement the wake-up receiver chain using CMOS technology, the parameters have been chosen to remain within practical and realistic limits, allowing for further optimization during the design process.

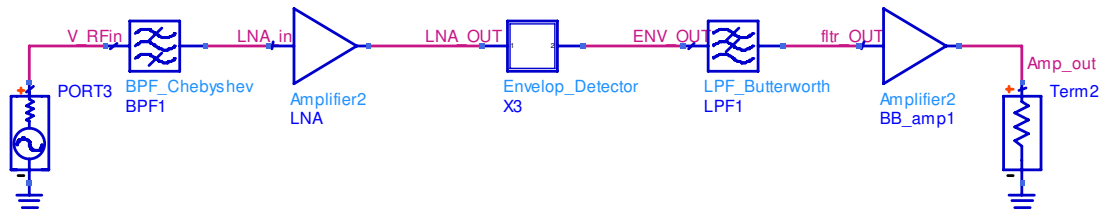

Fig. 5. Wake-up receiver system chain.

TABLE II. CIRCUIT BLOCKS REQUIREMENTS OF THE WAKE-UP RECEIVER FRONT END

Block	Parameter	Value
BPF	Fcenter	5.2 GHz
	BWpass	1 GHz
	BWstop	1.2 GHz
	Astop	20 dB
	ILoss	4 dB
LNA	S21	30 dB
	S11	-15 dB
	S22	-15 dB
	S12	-25 dB
	NF	1.6 dB
	IIP3	8 dBm
Envelope detector	Designed circuit	
LPF	Fpass	2.6 GHz
	Fstop	5.2 GHz
	Astop	70 dB
BBA	S21	35 dB
	S11	-15 dB
	S22	-15 dB
	S12	-25 dB
	NF	3 dB
	IIP3	24 dBm
P-1dB	14 dBm	

The only remaining unimplemented block is the envelope detector. This block should be designed in a separate ADS schematic, converted into a symbol, and integrated into the main wake-up receiver schematic. As one of the most essential components of the wake-up receiver, the envelope detector plays a critical role in signal processing. Further discussion of this block will be provided in the following section.

The minimum power consumption of the wake-up receiver can be estimated using the following equation:

$$P_{min, wake-up} = P_{min, LNA} + P_{min, BBA} \quad (1)$$

Each block's minimum power consumption is calculated as follows:

$$P_{min} = V_{DD} \times I_{total} \quad (2)$$

where:

- P_{min} is the estimated minimum power consumption of the block.
- V_{DD} is the supply voltage.
- I_{total} is the total current drawn by the active blocks (e.g., LNA, BBA).

It is important to note that, aside from the LNA and the BBA, the remaining blocks in the circuit are passive components, which do not consume power. The baseband filter typically consists of passive elements and is used to remove unwanted frequency components from the demodulated signal. While it does not actively consume power, its performance is critical to ensure signal clarity. On the other hand, the BBA is an active component and does contribute to power consumption. It is responsible for boosting the filtered signal to a level suitable for further processing or decision-making in the wake-up receiver. Careful design of the amplifier is necessary to maintain a balance between gain, noise performance, and power efficiency—especially in ultra-low-power applications like wake-up receivers.

ADS envelope simulation was used to simulate the signal spectrum. Figure 6 shows the simulated spectrum at the input of the wake-up receiver, the output of the LNA, the output of the envelope detector, and the output of the front end of the wake-up receiver. The peak signal energy in the spectrum concentrates around ± 5 GHz, with relatively little energy at DC. Figure 7 presents the simulated voltage behavior in the frequency domain at the at the same points in the circuit. Additionally, using harmonic balance, we can observe the voltage behavior at each receiver point, as shown in Figure 8.

Figure 11 demonstrates that the rise time of the output voltage depends on the capacitance value.

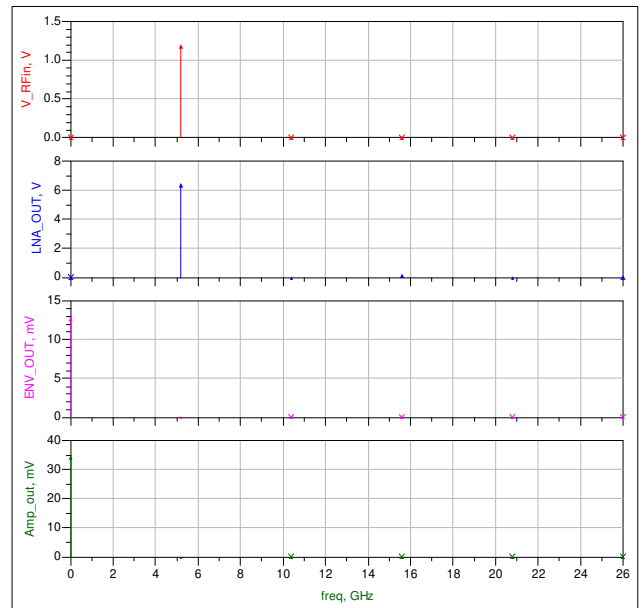

Fig. 7. Voltage behavior in frequency domain at each wake-up receiver point.

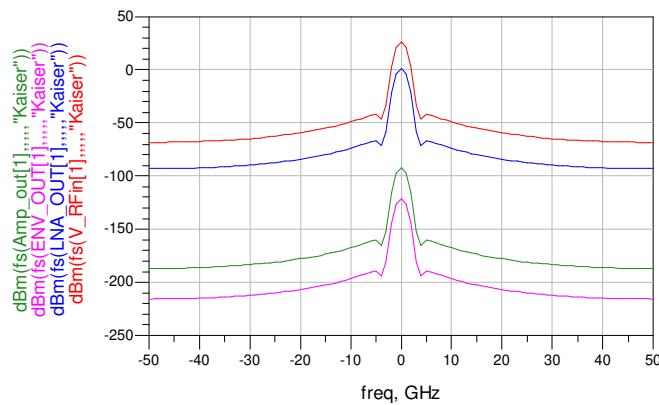

Fig. 6. Spectrum variation at each wake-up receiver point.

B. Envelope Detector Used

The WLAN signal produced by the RF source is an AC signal with very low input energy. Therefore, an RF-DC converter circuit, also called an envelope detector, is used to obtain a perfect DC voltage. The primary requirement for an RF-DC converter circuit is a high-frequency diode that should function in the GHz frequency range.

To reach maximum DC values, a combination of diodes and capacitors must be selected correctly. The two-diode passive envelope detector shown in Figure 9 uses a Schottky diode SMS7630-061 [11] with a low threshold voltage and a very short reverse recovery time [12]. It is known that the operating signal frequency is inversely proportional to the capacitor values used. Consequently, for an input frequency between 5 GHz and 5.5 GHz, the capacitor values will be in the pF range [13]. As shown in Figure 10, the output envelope detector voltage depends on the resistance value, whereas

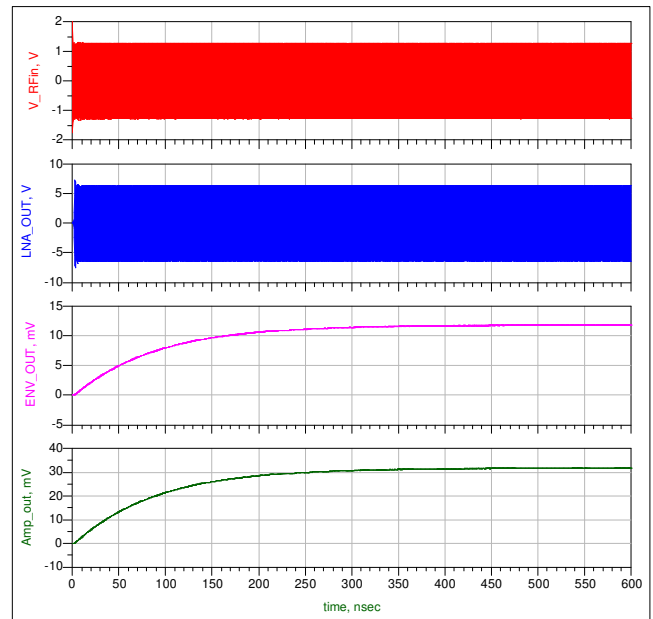

Fig. 8. Voltage behavior at each wake-up receiver point.

IV. IMPLEMENTATION OF THE WLAN WAKE-UP RECEIVER WITH TRANSMITTER CHAIN

A. Amplitude Modulation

Since OOK modulation is a particular case of Amplitude Modulation (AM), we use an AM modulation block in the transmitter chain to modulate the wake-up signal. Then, the

signal is amplified by a power amplifier. Figure 12 presents the transmitter chain-based AM modulation. Figure 13 shows the simulated spectrum at the input and output of the power amplifier and the transmitter output. The peak signal energy in the modulated BB spectrum concentrates around the

frequencies ± 10 MHz. Figure 14 presents the LNA output spectrum, the envelope detector output spectrum, and the wake-up receiver output spectrum for the AM signal. Figure 15 illustrates the voltage behavior at the transmitter output and at each wake-up receiver point.

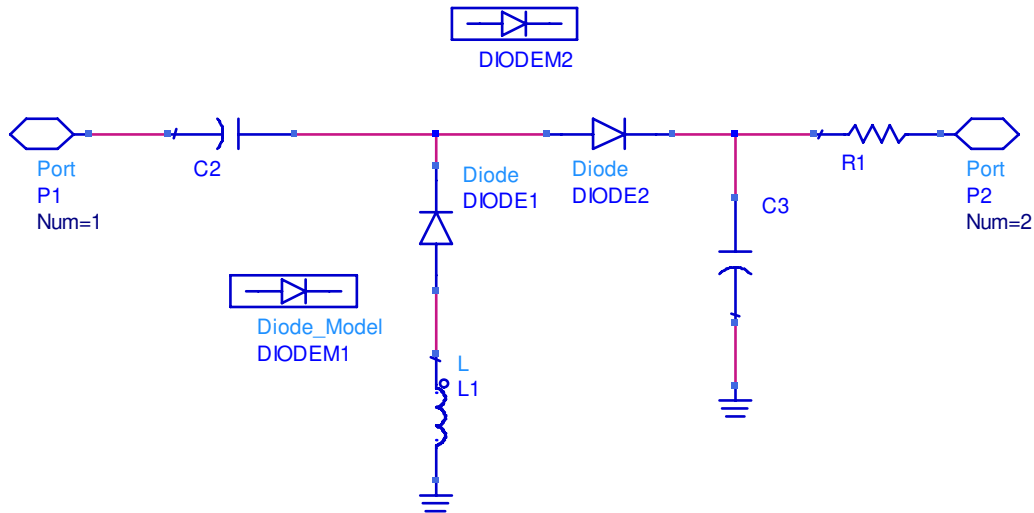

Fig. 9. Two-diode envelope detector.

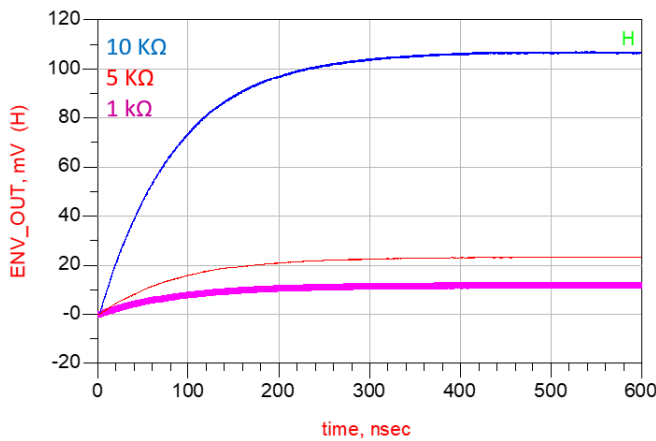

Fig. 10. Output voltage of the envelope detector as a function of the load resistance.

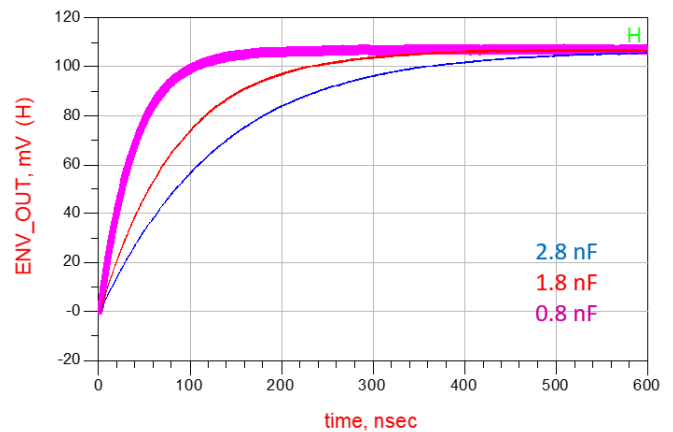

Fig. 11. Output voltage of the envelope detector as a function of the capacitance value.

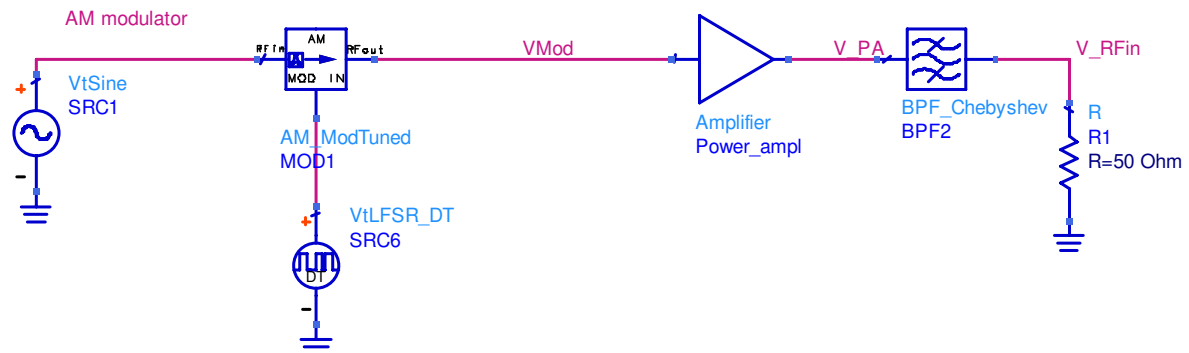

Fig. 12. Transmitter chain for AM modulation.

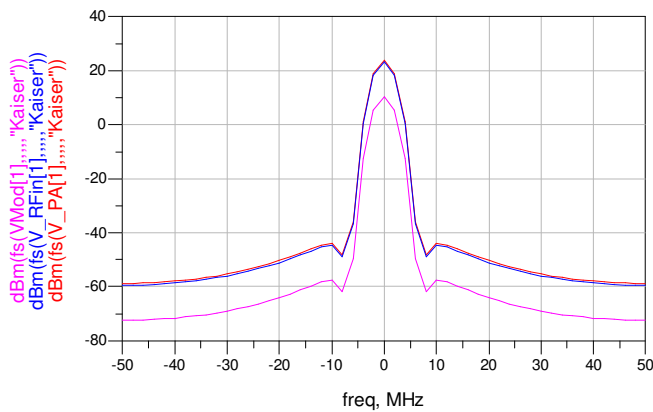

Fig. 13. Modulated signal spectrum, power amplifier output spectrum, and transmitter output spectrum for the AM signal.

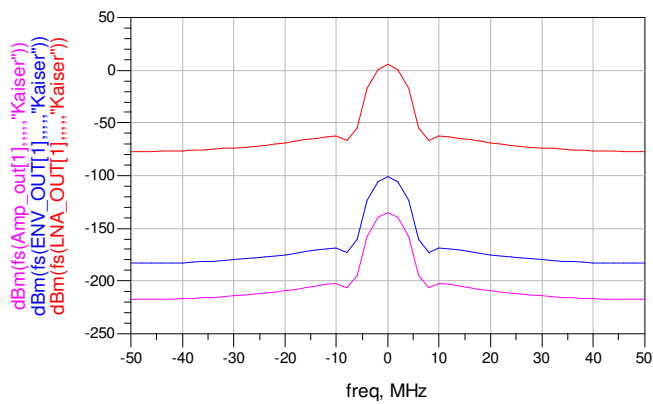

Fig. 14. Signal spectrum at the LNA, envelope detector, and wake-up receiver outputs for the AM signal.

B. Differential Quadrature Phase Shift Keying Modulation

Differential Quadrature Phase Shift Keying (DQPSK) is a variation of Quadrature Phase Shift Keying (QPSK) in which

there is no absolute carrier phase reference; rather, the transmitted signal itself is used as the phase reference. There are various applications of DQPSK, including WLANs, Bluetooth, and RFID communication. Since DQPSK modulation does not require a carrier at the receiver, complex circuits are not needed. Figure 16 presents the transmitter chain-based DQPSK modulation.

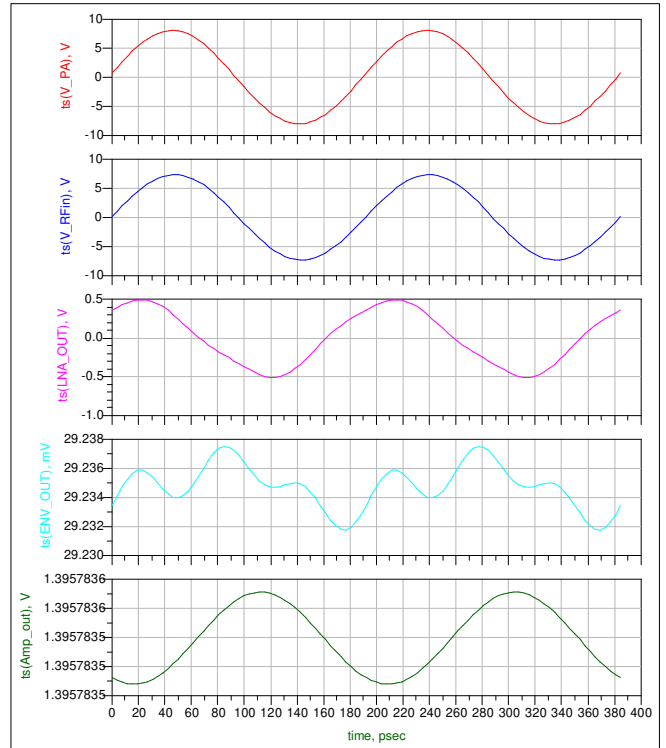

Fig. 15. Voltage behavior at the transmitter output and each wake-up receiver point.

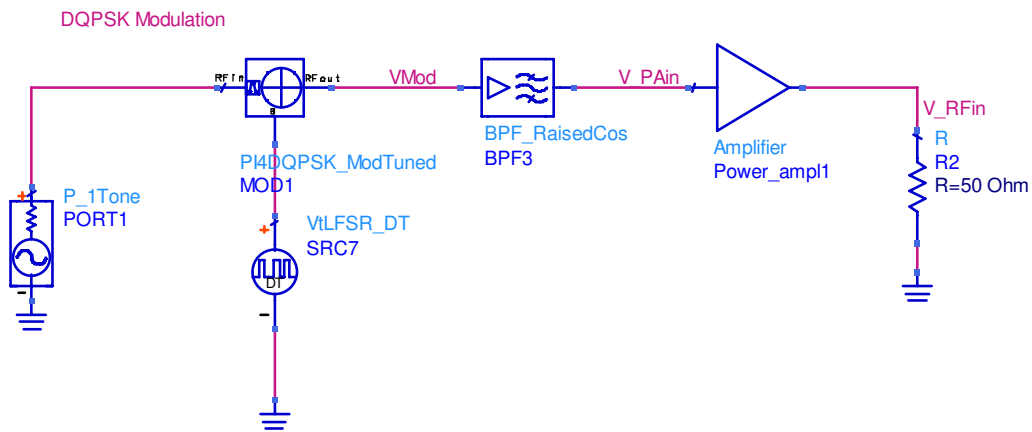

Fig. 16. Transmitter chain for DQPSK modulation.

Figure 17 shows the simulated spectrum at the transmitter output, LNA output, envelope detector output, and wake-up receiver output for the DQPSK signal. The peak signal energy in the modulated BB spectrum concentrates around the

frequencies ± 50 MHz. Figure 18 presents the voltage behavior at the transmitter output and at each wake-up receiver point. As shown in Figures 14 and 17, the wake-up receiver output spectrum is 50% better with DQPSK modulation compared to

AM modulation. Since we are using the same parameters for both modulations as listed in Table II, we can observe the impact of DQPSK modulation on the output of the envelope detector and the wake-up receiver. With this modulation, we can decrease the gain of the BBA or decrease the capacitance and resistance values of the envelope detector, allowing for easy implementation in CMOS technology.

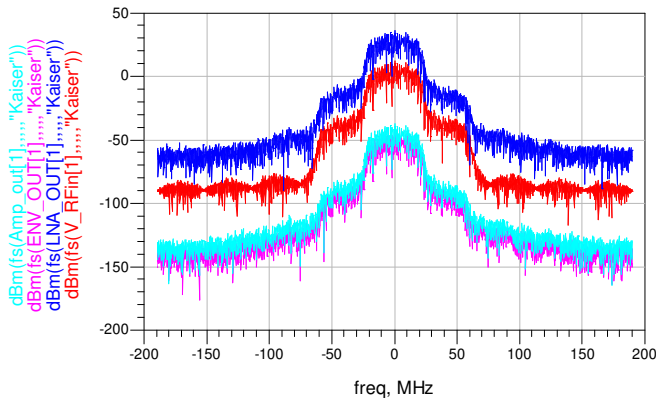

Fig. 17. The transmitter output spectrum, LNA output spectrum, envelope detector output spectrum and wake-up receiver output spectrum for DQPSK signal.

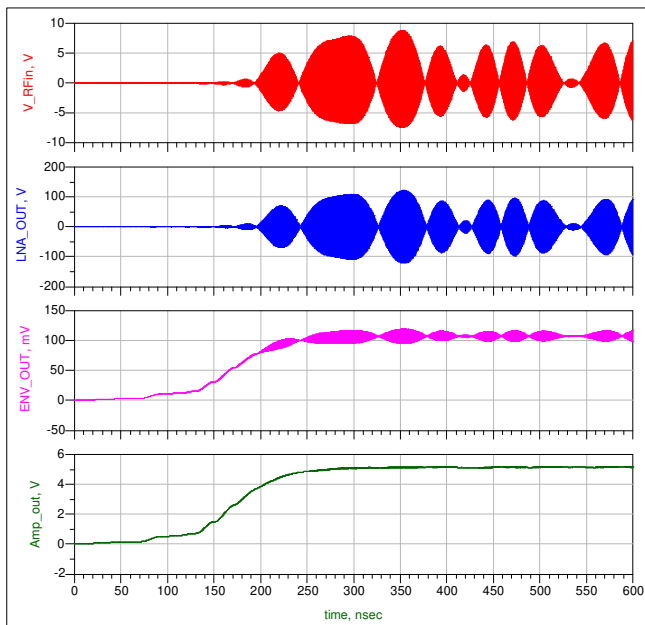

Fig. 18. The behavior of the voltage at output transmitter and each wake-up receiver point.

V. CONCLUSION

Wake-up receivers are critical components in energy-constrained wireless systems such as the Internet of Things (IoT) and wireless local area networks (WLANs), enabling ultra-low power communication. However, achieving an optimal balance between sensitivity, power consumption, and design simplicity, especially within CMOS implementation constraints, remains a key design challenge. This study

addressed these challenges by exploring various wake-up receiver architectures and identifying key design trade-offs. A WLAN-targeted wake-up receiver was modeled and validated using block-level simulations in Advanced Design System (ADS) software with design parameters aligned to the 0.18 μm CMOS process to assess practical feasibility.

Additionally, a performance comparison was conducted between Amplitude Modulation (AM) and Differential Quadrature Phase Shift Keying (DQPSK). The results demonstrate that DQPSK provides a 50% improvement in the output spectrum compared to AM, which could lead to reduced gain requirements in the Baseband Amplifier (BBA) or a simpler envelope detector design, both of which are favorable for CMOS integration.

The novelty of this work lies in its combination of modulation-level analysis and CMOS-aware simulation, offering theoretical insight and practical design guidance. These findings serve as a useful reference for designers developing energy-efficient wake-up receivers for WLANs and low-power wireless communication systems.

ACKNOWLEDGMENT

This study is supported by funding from Prince Sattam bin Abdulaziz University under project number PSAU/2025/R/1446.

REFERENCES

- [1] T. Kramp, R. van Kranenburg, and S. Lange, "Introduction to the Internet of Things," in *Enabling Things to Talk: Designing IoT solutions with the IoT Architectural Reference Model*, A. Bassi, M. Bauer, M. Fiedler, T. Kramp, R. van Kranenburg, S. Lange, and S. Meissner, Eds. Berlin, Heidelberg, Germany: Springer, 2013, pp. 1–10, https://doi.org/10.1007/978-3-642-40403-0_1.
- [2] P.-H. P. Wang, C. Zhang, H. Yang, M. Dunna, D. Bharadia, and P. P. Mercier, "A Low-Power Backscatter Modulation System Communicating Across Tens of Meters With Standards-Compliant Wi-Fi Transceivers," *IEEE Journal of Solid-State Circuits*, vol. 55, no. 11, pp. 2959–2969, Nov. 2020, <https://doi.org/10.1109/JSSC.2020.3023956>.
- [3] N. E. Roberts *et al.*, "26.8 A 236nW–56.5dBm-sensitivity bluetooth low-energy wakeup receiver with energy harvesting in 65nm CMOS," in *2016 IEEE International Solid-State Circuits Conference*, San Francisco, CA, USA, 2016, pp. 450–451, <https://doi.org/10.1109/ISSCC.2016.7418101>.
- [4] P. P. Mercier *et al.*, "Low-Power RF Wake-Up Receivers: Analysis, Tradeoffs, and Design," *IEEE Open Journal of the Solid-State Circuits Society*, vol. 2, pp. 144–164, 2022, <https://doi.org/10.1109/OJSSCS.2022.3215099>.
- [5] J. Im, J. Breiholz, S. Li, B. Calhoun, and D. D. Wenzloff, "A Fully Integrated 0.2V 802.11ba Wake-Up Receiver with -91.5dBm Sensitivity," in *2020 IEEE Radio Frequency Integrated Circuits Symposium*, Los Angeles, CA, USA, 2020, pp. 339–342, <https://doi.org/10.1109/RFIC49505.2020.9218383>.
- [6] S. Bdiri, F. Derbel, and O. Kanoun, "A Tuned-RF Duty-Cycled Wake-Up Receiver with -90 dBm Sensitivity," *Sensors*, vol. 18, no. 1, Jan. 2018, Art. no. 86, <https://doi.org/10.3390/s18010086>.
- [7] R. Ma, F. Protze, and F. Ellinger, "A 193-nW Wake-Up Receiver Achieving -84.5-dBm Sensitivity for Green Wireless Communications," *IEEE Transactions on Green Communications and Networking*, vol. 6, no. 1, pp. 512–529, Mar. 2022, <https://doi.org/10.1109/TGCN.2021.3101902>.
- [8] H. Ren *et al.*, "A 915MHz 19 μW Blocker-Enhanced Wake-Up Receiver with Frequency-Hopping Two-Tone Modulation Achieving 53dB Tolerance to In-Band Interference," in *2022 IEEE Radio Frequency*

- Integrated Circuits Symposium*, Denver, CO, USA, 2022, pp. 299–302, <https://doi.org/10.1109/RFIC54546.2022.9863142>.
- [9] S. Talari and P. C. Sekhar, "A High Gain Dual Band Hexagonal Metamaterial Inspired Antenna for 5G Applications," *Engineering, Technology & Applied Science Research*, vol. 14, no. 6, pp. 18029–18035, Dec. 2024, <https://doi.org/10.48084/etasr.8575>.
- [10] L.-T. Wang, Y. Xiong, and M. He, "Review on UWB Bandpass Filters," in *UWB Technology - Circuits and Systems*, M. Kheir, Ed. London, United Kingdom: IntechOpen, 2019, <https://doi.org/10.5772/intechopen.87204>.
- [11] M. Bouraoui, A. Neifar, I. Barraji, and M. Masmoudi, "Low-Power Envelope Detector for WSN Wake-up Receiver Applications," in *2023 IEEE International Conference on Design, Test and Technology of Integrated Systems*, Gammarth, Tunisia, 2023, pp. 1–5, <https://doi.org/10.1109/DTTIS59576.2023.10348315>.
- [12] W. Samakkhee, K. Phaebua, and T. Lertwiriayaprapa, "5.8 GHz rectifier circuit for electromagnetic energy harvesting system," in *2017 International Symposium on Antennas and Propagation (ISAP)*, Phuket, Thailand, 2017, pp. 1–2, <https://doi.org/10.1109/ISANP.2017.8229029>.
- [13] E. Mousa Ali, N. Z. Yahaya, P. Nallagownden, and M. A. Zakariya, "A novel rectifying circuit for microwave power harvesting system," *International Journal of RF and Microwave Computer-Aided Engineering*, vol. 27, no. 4, Apr. 2017, Art. no. e21083, <https://doi.org/10.1002/mmce.21083>.