

Application of Seasonal Trend Decomposition using Loess and Long Short-Term Memory in Peak Load Forecasting Model in Tien Giang

Ngoc-Hung Duong

Ho Chi Minh City University of Technology and Education, Vietnam | Tien Giang University, Vietnam
duongngochung@tgu.edu.vn (corresponding author)

Minh-Tam Nguyen

Ho Chi Minh City University of Technology and Education, Vietnam
tamnm@hcmute.edu.vn

Thanh-Hoan Nguyen

Department of Information Technology, Ho Chi Minh Power Corporation (EVNHCMC), Vietnam
hoan2nt@hcmpp.com.vn

Thanh-Phong Tran

LARIS, Polytech Angers, University of Angers, France | Tien Giang University, Vietnam
thanhhphong.tran@univ-angers.fr

Received: 13 July 2023 | Revised: 1 August 2023 | Accepted: 4 August 2023

Licensed under a CC-BY 4.0 license | Copyright (c) by the authors | DOI: <https://doi.org/10.48084/etasr.6181>

ABSTRACT

Daily peak load forecasting is critical for energy providers to meet the loads of grid-connected consumers. This study proposed a Seasonal Trend decomposition using Loess combined with Long Short-Term Memory (STL-LTSM) method and compared its performance on peak forecasting of electrical energy demand with Convolutional Neural Network and LSTM (CNN-LSTM), Wavenet, and the classic approaches Artificial Neural Network (ANN) and LSTM. The study evaluated the models using demand data from the power system in Tien Giang province, Vietnam, from 2020 to 2022, considering historical demand, holidays, and weather variables as input characteristics. The results showed that the proposed STL-LSTM model can predict future demand with lower Base Mean Square Error (RMSE) and Mean Absolute Percentage Error (MAPE). Therefore, the proposed method can help energy suppliers make smart decisions and plan for future demand.

Keywords-Wavenet; LSTM; CNN; STL; peak load forecasting

I. INTRODUCTION

In current development trends, technology occupies an increasingly large part of life. Thus, the electricity demand is increasing rapidly along with the development of microgrids [1]. Microgrid models in the form of a small-scale power grid with advanced techniques and tools are designed for optimal energy operation [2]. The importance of consumer load forecasting is increasingly emphasized [3]. The problem of forecasting peak loads is considered complicated. Accurate short-term forecast results support efficient and convenient operation and exploitation of a power system in an area. If the prediction indicates that the storage capacity is insufficient to support future loads, the power company may notify users of this status, causing them to reduce their electricity usage. In [4],

a hybrid approach was proposed for short-term forecasting of load demand in a typical microgrid, which was a combination of a static wavelet packet transform and a feedforward neural network based on the Harris Hawks Optimization (HHO) algorithm. HHO is applied to a feedforward neural network as an alternative training algorithm to optimize the weights and basis of neurons. In [5], Wavenet with dilating causal complexes and connection skip was used to work with long-term information, presenting various advantages compared to other statistical algorithms.

Many forecasting methods have been proposed to solve the load forecasting problem. These approaches are classified as statistical, persistence, machine learning, and association approaches [4]. In [7], a multiple linear regression model was presented to predict the hourly basic load demand [8], using the

trial-and-error method to determine the appropriate structure of the proposed model. A regression-based moving window with an adjustable window size-based method was presented in [9]. This method was compared with a Back-Propagation-based Neural Network (BPNN) to show the effectiveness of the regression-based moving window strategy. In [10], load forecasting was carried out in a microgrid using the persistence method. In [11-12], a Kalman filter-based model was proposed to forecast the short-term load demand of a household, comparing its performance with existing competing methods. Other models, such as autoregressive moving average with exogenous variables (ARMAX) [13-14], Auto-Regression Integrated Moving Average (ARIMA) [15], Seasonal ARIMA (SARIMA) [16], and modified autoregressive moving average (ARMA) [17], were suggested for short-term load forecasting. However, these methods were not capable of handling nonlinear load characteristics, limiting their application.

Machine learning and composite approaches are considered to be powerful techniques for dealing with the nonlinear properties of loads. Machine learning approaches include Support Vector Machines (SVMs) and Artificial Neural Networks (ANNs) [18]. In [19-22], decomposition with Loess forecasting (STLF) was carried out by applying both SVM and a seasonally adjusted SVM-based association model (SSA-SVM). SSA-SVM was compared with seasonally integrated wavelet-based ANN and simple ANN, showing its superior performance. Several combined approaches were applied to load forecasting, such as SVM-based Particle Swarm Optimization (PSO) [23], Genetic Algorithm (GA) with SVM [24], firefly algorithm (FFA) SVM [25-26], SVM-based Grasshopper Optimization Algorithm (GOA) [27], improved fruit fly optimization algorithm based on SVM [28], horizontal movement algorithm based on hybrid PSO and SVM [29], Experimental Mode Decomposition (EMD) [30], and Wavelet Transform (WT) with PSO-SVM [31]. Least Squares SVM (LSSVM) is an improved type of SVM that has also been applied to load forecasting. In [32], LSSVM and LSSVM with PSO for STLF were compared with conventional approaches to demonstrate their effectiveness. A hybrid WT with Fruit Fly Optimization (FFO) and a sperm whale-based LSSVM algorithm were proposed in [33] for STLF, showing outstanding performance.

The machine learning methods have some disadvantages, such as difficulty in parameter selection and unclear choice of input variables. This study proposed an improved peak load forecasting approach using the Seasonal Trend decomposition using Loess (STL) combined with LSTM (STL-LSTM). The proposed STL-LSTM method was compared with some other competing models, such as ANN, LSTM, CNN-LSTM, and Wavenet, to evaluate its performance.

II. THE PROPOSED ALGORITHM

A. Methodology

1) Seasonal Trend Decomposition Using Loess (STL)

STL is a statistical technique that decomposes a time series into three parts: seasonality, trend, and residual [2]. It uses the locally weighted regression method, commonly known as

Loess, to identify seasonal components and trends, while residuals are calculated by subtracting seasonal components and estimated trends from the initial time series. The trend component represents the long-term trend of the time series, while the seasonal component represents cyclical variations. Finally, the residual component captures fluctuations that cannot be predicted. The third panel of Figure 1 shows a seasonal component, with data variation of one cycle per year. The residual component, shown in the fourth panel of Figure 1, is the remaining variation in the data beyond the seasonal and trend components. Suppose that Y_t is the value of the time series, S_t is the value of the seasonal component, T_t is the value of the trend component, and R_t is the value of the residual component at point t , for $t = 1 \dots n$. The three components of STL analysis relate to the raw time series as follows:

$$Y_t = S_t + T_t + R_t \quad (1)$$

In previous studies, the STL method was applied to separate the data into three distinct parts, which were independently analyzed for training, validation, and testing sets. These components were used to predict the upcoming values of the time series.

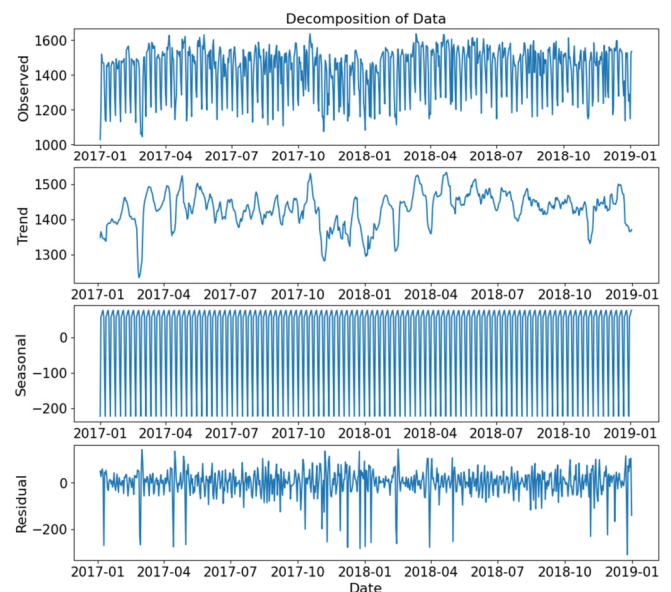

Fig. 1. Extracted samples of hourly and weekly seasonal components.

2) Long Short-Term Memory (LSTM)

LSTM is a Recurrent Neural Network (RNN) architecture that has gained popularity due to its ability to effectively handle long-term dependencies in sequential data. Unlike traditional RNNs, LSTM uses gates and memory cells to selectively retain or forget information from previous time steps. This unique mechanism prevents the vanishing gradient problem commonly encountered in RNNs. Moreover, LSTMs are well suited for tasks that require modeling long-term dependencies, thanks to their capability to store information over extended periods. Numerous studies on load forecasting have demonstrated the efficiency of LSTM networks [9].

Time-series data plays a crucial role in power load analysis. When it comes to time-series forecasting, RNNs offer distinct advantages compared to feedforward neural networks. However, RNNs face two primary challenges during training. Firstly, as training progresses further into the past, the influence of the gradient signal diminishes, making it less effective for capturing long-term dependencies. This issue is commonly known as the gradient vanishing problem. Second, at each training step, the gradient must be calculated for the activation function. If the result exceeds one, the gradient update grows exponentially, particularly with an increasing number of layers, leading to a gradient explosion.

This study proposes a load forecasting model based on LSTM neural networks as a solution to the limitations of RNNs. LSTM networks are an enhanced version of RNNs, featuring a distinctive structure. The RNN network comprises a repeating module with a straightforward design, as shown in Figure 2. Each module in the RNN network includes a single layer. On the other hand, the LSTM network shares a structure similar to the RNN, except for the presence of the memory cell module, as illustrated in Figure 3. In contrast to the single-layer architecture of RNNs, LSTM neural networks involve four distinct interacting layers.

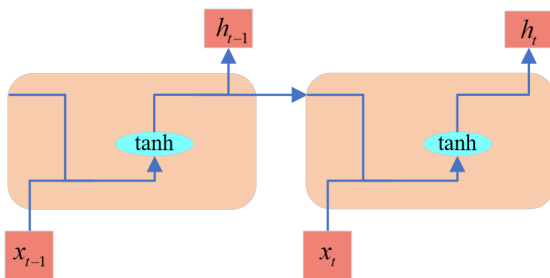

Fig. 2. The chain of RNN.

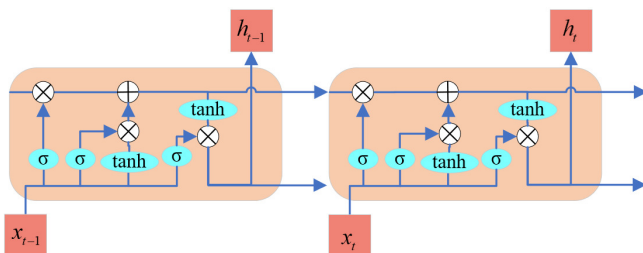

Fig. 3. The chain of LSTM neural network.

The LSTM neural network model has four parts: an input, an output, a forget, and an update part, as shown in Figure 3. In Figure 3, x_t is multiplied by f_t . The unimportant information x_t represents the input at time t , h_t represents the hidden state at time t , c_t represents the cell state at time t , and σ denotes a logistic sigmoid function that returns a probability value between zero and one, indicating the possibility of signal transmission. A value of 0 indicates that the signal cannot pass, while 1 indicates that all signals are allowed to pass.

Each cell in an LSTM network has a complex structure, controlled by three gates: a forget, an input, and an output.

Cells manipulate information in the network using these three gates to remove or add information to the cell state c_t , i.e. "memory". The forget gate determines the forgetting level, as shown in Figure 4(a), f_t representing the gate control switch of the forget gate, which controls the number of forgotten previous cell states. Similarly to human memory, a forget gate can perform the function of forgetting unimportant information while retaining important information.

$$f_t = \sigma(W_f[h_{t-1}, x_t] + b_f) \tag{2}$$

Figure 4(b) shows the input port that receives new information from the peripheral input and chooses to remember the information in the current state and the data in the previously hidden state. This creates a new vector to hold the data, which can be updated. In the input port, the tanh class defines the candidate value of the updated content and the sigmoid class defines the updated content. The probability value ranges from 0 to 1.

$$i_t = \sigma(W_i[h_{t-1}, x_t] + b_i) \tag{3}$$

$$\tilde{c}_t = \tanh(W_c[h_{t-1}, x_t] + b_c) \tag{4}$$

The next step involves updating the cell state, as shown in Figure 4(c). This process is as follows. At first, c_{t-1} is multiplied by f_t . Then the unimportant information is forgotten and the important information is retained. Finally, the information remaining in the current input is retained to obtain the latest cell state. This step varies depending on how updated each state is:

$$c_t = f_t \cdot c_{t-1} + i_t \cdot \tilde{c}_t \tag{5}$$

The sigmoid layer in the output gate defines the output from the current cell state, as shown in Figure 4(d). This process is performed using the tanh function. The output of the sigmoid layer is then multiplied by the processed value between -1 and 1 to obtain the output. Finally, the output gate switches the c_t cell state, and the obtained h_t output to the next cell is calculated as follows:

$$o_t = \sigma(W_o[h_{t-1}, x_t] + b_o) \tag{6}$$

$$h_t = o_t \cdot \tanh(c_t) \tag{7}$$

where W_f , W_i , W_c , and W_o are the weight matrices of forget gate, input port, cell state, and output port, respectively, and b_f , b_i , b_c , and b_o are the bias vectors, respectively.

The traditional LSTM neural network model solves the problem of n -step prediction by adding a thick layer when providing the h_t output. This maps the hidden state to an n -dimensional vector, which in turn responds to the data format of the problem. The n steps are predicted completely independently at this point. Therefore, string dependencies between output labels are not considered when using LSTM for prediction. Furthermore, LSTM cannot support variable-length input. If a sensor suddenly crashes during monitoring, resulting in partial loss of predictive data, LSTM may not complete the training. These limitations can be addressed by employing the proposed model for electric load forecasting, which combines STL with LSTM. Figure 5 shows this sequential approach method.

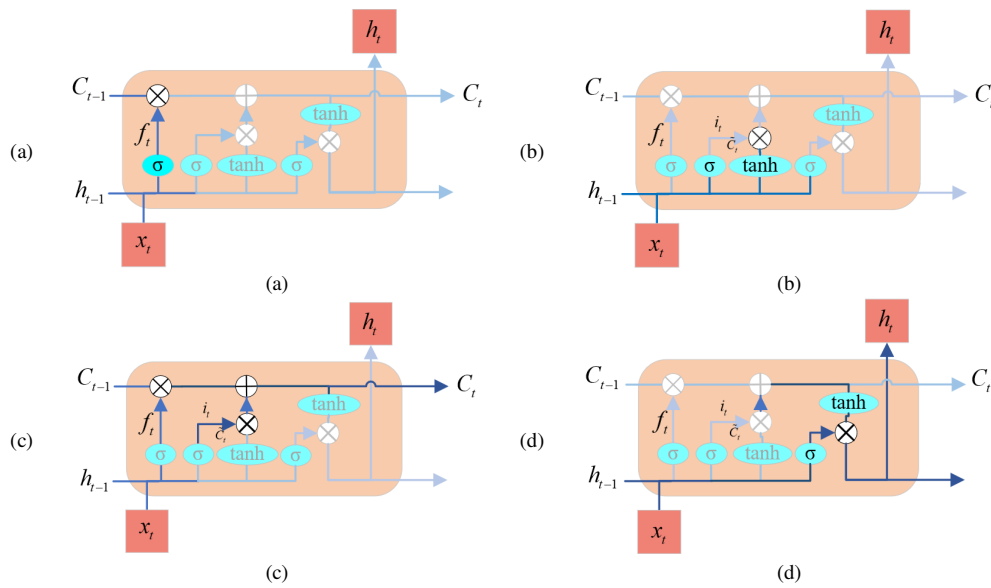

Fig. 4. Structure of a cell in an LSTM neural network: (a) Forget gate, (b) input port, (c) status update section, and (d) output port.

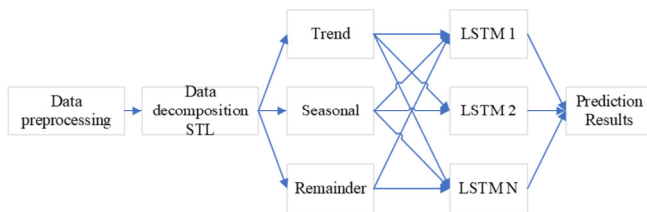

Fig. 5. Flowchart of the STL-LSTM model.

The dataset was first normalized between 0 and 1 using the Min-Max-Scaler for LSTM analysis. Then a lookback window of 1 was applied, where the input sequence was a sliding window of time steps and the output was a single value. The data were reshaped to fit the input geometry of the LSTM layer. This model consists of a hidden layer with 64 units, followed by a density output layer with a linear activation function. The model was compiled using the Adam optimizer and the mean-squared loss function. The model was trained and validated using prepared training and validation datasets. During training, the model's loss and the validation loss were used to evaluate its performance.

B. Experiment

1) Dataset

A dataset on the electric load of Tiền Giang province, Vietnam, from 2020 to 2022 was used to evaluate the proposed method. Figure 6 shows some sample data. To address the problem of load forecasting, in addition to demand periodicity, factors that affect power consumption were considered. In addition to the periodicity of demand, weather factors such as outdoor temperature, humidity, solar irradiance, and wind speed during the day were included. Time factors such as festivals or economic factors play an important role in the accurate prediction of loads. However, the collection of these external factors is very complicated, and the collected data are usually expressed as continuous and cyclic time series during

the day. This study evaluated data by timeline, time coding by day, week, month, holiday, and local outdoor temperature for the corresponding period. Figure 7 shows the temperature (in °C, orange) and electrical load (in kWh, blue) in Tien Giang for the corresponding time in a day.

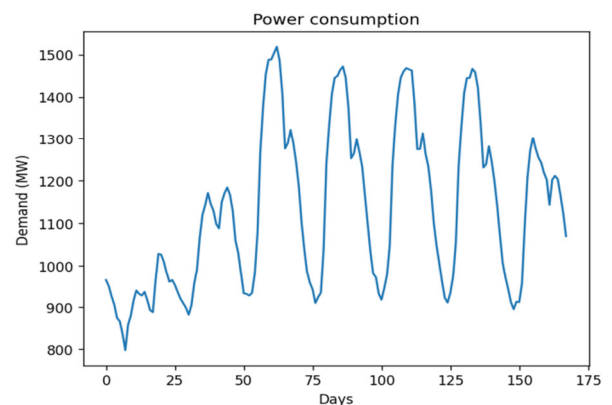

Fig. 6. Electricity load data for a week in Tien Giang.

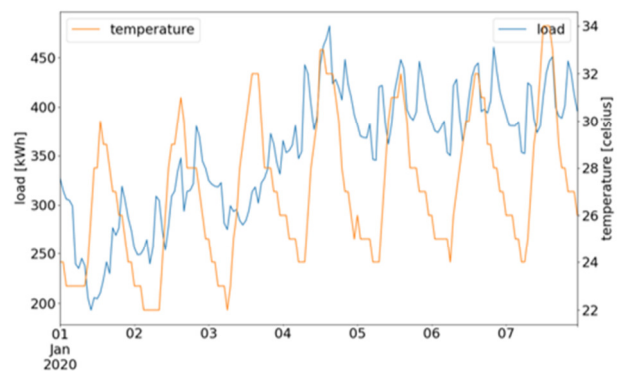

Fig. 7. Electricity and temperature data for a week in Tien Giang.

It can be seen that the load profile is significantly influenced by the temperature data variation. Therefore, the outdoor temperature acts as a highly correlated factor with the electrical load data. During the tests, the input data was normalized to the interval [0, 1]. Furthermore, 80% of the data was used for training and the remaining 20% was used for testing. These data were processed to predict the maximum daily load. Figure 8 shows daily peak data with seasonal features.

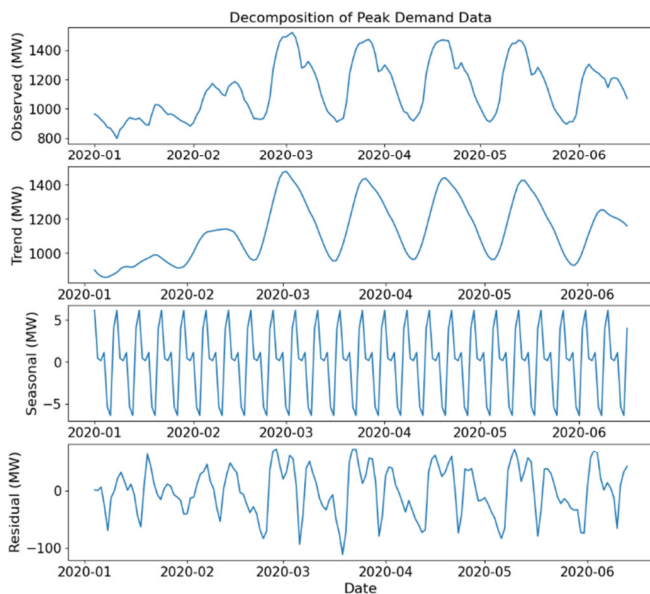

Fig. 8. Observations, trends, seasons, and residuals of peak demand.

2) Evaluation Indicators

Five metrics were used to evaluate the predictive performance of the T-GCN model on Y_t and the predicted \hat{Y}_t : Root Mean Squared Error (RMSE), Mean Absolute Percentage Error (MAPE), Accuracy, coefficient of determination (R^2), and explained variance score (Var). The following equations show the calculation formulas:

$$RMSE = \sqrt{\frac{1}{n} \sum_{t=1}^n (Y_t - \hat{Y}_t)^2} \tag{8}$$

$$MAPE = \frac{1}{n} \sum_{t=1}^n |Y_t - \hat{Y}_t| \tag{9}$$

$$Accuracy = 1 - \frac{\|Y - \hat{Y}\|_F}{\|Y\|_F} \tag{10}$$

$$R^2 = 1 - \frac{n(RMSE)^2}{\sum_{t=1}^n (Y_t - \bar{Y})^2} \tag{11}$$

$$Var = 1 - \frac{Var\{Y - \hat{Y}\}}{Var\{Y\}} \tag{12}$$

RMSE and MAE are used to measure prediction error, while their smaller values indicate greater accuracy. Accuracy is used to detect the accuracy of the prediction, and higher values indicate greater accuracy. R^2 and Var measure the ability of the predicted results to represent the actual data, and larger values indicate better prediction accuracy. To assess the effectiveness

of the LSTM model, the Training loss over the training epochs was examined, as shown in Figure 9.

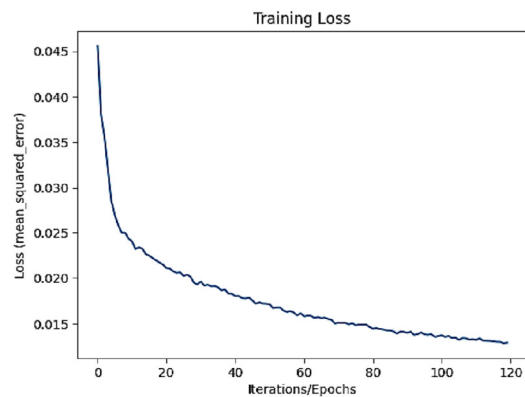

Fig. 9. Training loss of the LSTM model through the number of iterations.

3) Error Evaluation Results

Table I shows the performance of the models evaluated. The proposed model performed better in most criteria. The RMSE and MAPE coefficients clearly show the superiority of the proposed STL-LSTM method, as it scored lower values.

TABLE I. FORECAST RESULTS

Model	RMSE	MAPE (%)
ANN	1509.5	6.34
LSTM	730.87	4.96
CNN-LSTM	359.18	2.08
Wavenet	298.93	1.66
STL-LSTM	292.53	1.52

According to the results in Table I, the forecasting model using ANN gave the highest error results. The LSTM model and the CNN-LSTM gave better MAPE of 4.96% and 2.08%, respectively. In the Wavenet pattern, MAPE dropped significantly to 1.66 and had an RMSE of 298.93. Overall, the results demonstrate that the integration of STL with LSTM significantly improved forecasting accuracy, as its MAPE of 1.52% and RMSE of 292.53 indicate that it produced highly accurate forecasts, with significantly lower errors.

The superiority of the proposed STL-LSTM model demonstrates that it could be a promising approach to time-series forecasting and capture of correlated characteristics that can be decomposed into seasonal and trend components. However, further analysis and validation on different datasets and periods are necessary to confirm its generalizability and robustness.

4) Forecast Graph Results

Figure 10 displays the forecast results, showing the actual (blue) and forecast (red) data. The proposed STL-LSTM method exhibited better accuracy since the forecast results and the actual data almost coincide. The other methods had large errors, showing greater divergence between the actual and forecast data.

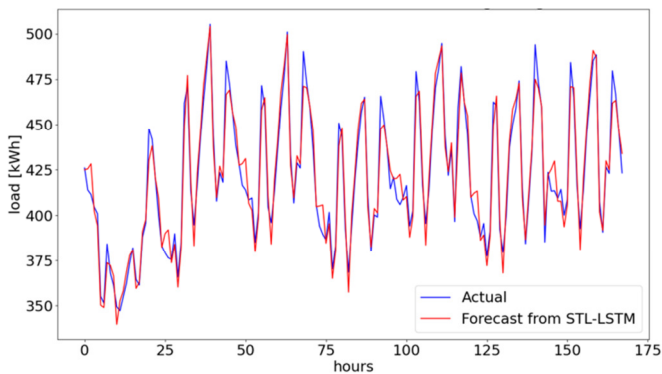

Fig. 10. Comparison of actual value and proposed STL-LSTM network aggregation method.

III. CONCLUSION

The presented results show that the proposed STL-LSTM method had improved performance in terms of *MAPE* and *RMSE*. By integrating STL and LSTM, the model can capture both short-term and long-term variations in the time series, while preserving the ability to model the seasonal component of the data. This integration is particularly beneficial for forecasting seasonal time series, where the method needs to accurately predict both seasonal and non-seasonal components. In summary, integrating STL into LSTM enables the model to learn both the seasonal and noise components, resulting in improved forecasting performance. This approach can lead to better results in time series forecasting tasks. However, a drawback of the proposed STL-LSTM model is that its algorithm is more computationally intensive and time-consuming than the other compared methods. In the future, the algorithm will be expanded to be able to optimize multiple values at the same time and reduce its computational resource consumption, while maintaining or improving its performance.

REFERENCES

- [1] N. Ahmad, Y. Ghadi, M. Adnan, and M. Ali, "Load Forecasting Techniques for Power System: Research Challenges and Survey," *IEEE Access*, vol. 10, pp. 71054–71090, 2022, <https://doi.org/10.1109/ACCESS.2022.3187839>.
- [2] M. Fan, Y. Hu, X. Zhang, H. Yin, Q. Yang, and L. Fan, "Short-term Load Forecasting for Distribution Network Using Decomposition with Ensemble prediction," in *2019 Chinese Automation Congress (CAC)*, Hangzhou, China, Aug. 2019, pp. 152–157, <https://doi.org/10.1109/CAC48633.2019.8997169>.
- [3] N. T. Dung and N. T. Phuong, "Short-Term Electric Load Forecasting Using Standardized Load Profile (SLP) And Support Vector Regression (SVR)," *Engineering, Technology & Applied Science Research*, vol. 9, no. 4, pp. 4548–4553, Aug. 2019, <https://doi.org/10.48084/etasr.2929>.
- [4] J. Zhu, H. Dong, W. Zheng, S. Li, Y. Huang, and L. Xi, "Review and prospect of data-driven techniques for load forecasting in integrated energy systems," *Applied Energy*, vol. 321, Sep. 2022, Art. no. 119269, <https://doi.org/10.1016/j.apenergy.2022.119269>.
- [5] F. Dorado Rueda, J. Durán Suárez, and A. del Real Torres, "Short-Term Load Forecasting Using Encoder-Decoder WaveNet: Application to the French Grid," *Energies*, vol. 14, no. 9, Jan. 2021, Art. no. 2524, <https://doi.org/10.3390/en14092524>.
- [6] D. Niu, Y. Wang, and D. D. Wu, "Power load forecasting using support vector machine and ant colony optimization," *Expert Systems with Applications*, vol. 37, no. 3, pp. 2531–2539, Mar. 2010, <https://doi.org/10.1016/j.eswa.2009.08.019>.
- [7] G. F. Fan, Y. H. Guo, J. M. Zheng, and W. C. Hong, "Application of the Weighted K-Nearest Neighbor Algorithm for Short-Term Load Forecasting," *Energies*, vol. 12, no. 5, Jan. 2019, Art. no. 916, <https://doi.org/10.3390/en12050916>.
- [8] S. K. Filipova-Petrakieva and V. Dochev, "Short-Term Forecasting of Hourly Electricity Power Demand: Regression and Cluster Methods for Short-Term Prognosis," *Engineering, Technology & Applied Science Research*, vol. 12, no. 2, pp. 8374–8381, Apr. 2022, <https://doi.org/10.48084/etasr.4787>.
- [9] Y. Dong, Z. Zhang, and W. C. Hong, "A Hybrid Seasonal Mechanism with a Chaotic Cuckoo Search Algorithm with a Support Vector Regression Model for Electric Load Forecasting," *Energies*, vol. 11, no. 4, 2018, <https://doi.org/10.3390/en11041009>.
- [10] R. Zhang, Z. Y. Dong, Y. Xu, K. Meng, and K. P. Wong, "Short-term load forecasting of Australian National Electricity Market by an ensemble model of extreme learning machine," *IET Generation, Transmission & Distribution*, vol. 7, no. 4, pp. 391–397, 2013, <https://doi.org/10.1049/iet-gtd.2012.0541>.
- [11] M. Ghofrani, M. Ghayekhloo, A. Arabali, and A. Ghayekhloo, "A hybrid short-term load forecasting with a new input selection framework," *Energy*, vol. 81, pp. 777–786, Mar. 2015, <https://doi.org/10.1016/j.energy.2015.01.028>.
- [12] W. Kong, Z. Y. Dong, Y. Jia, D. J. Hill, Y. Xu, and Y. Zhang, "Short-Term Residential Load Forecasting Based on LSTM Recurrent Neural Network," *IEEE Transactions on Smart Grid*, vol. 10, no. 1, pp. 841–851, Jan. 2019, <https://doi.org/10.1109/TSG.2017.2753802>.
- [13] C. Tian, J. Ma, C. Zhang, and P. Zhan, "A Deep Neural Network Model for Short-Term Load Forecast Based on Long Short-Term Memory Network and Convolutional Neural Network," *Energies*, vol. 11, no. 12, 2018, <https://doi.org/10.3390/en11123493>.
- [14] L. Han, Y. Peng, Y. Li, B. Yong, Q. Zhou, and L. Shu, "Enhanced Deep Networks for Short-Term and Medium-Term Load Forecasting," *IEEE Access*, vol. 7, pp. 4045–4055, 2019, <https://doi.org/10.1109/ACCESS.2018.2888978>.
- [15] K. Park, S. Yoon, and E. Hwang, "Hybrid Load Forecasting for Mixed-Use Complex Based on the Characteristic Load Decomposition by Pilot Signals," *IEEE Access*, vol. 7, pp. 12297–12306, 2019, <https://doi.org/10.1109/ACCESS.2019.2892475>.
- [16] B. J. Chen, M. W. Chang, and C. J. Lin, "Load forecasting using support vector Machines: a study on EUNITE competition 2001," *IEEE Transactions on Power Systems*, vol. 19, no. 4, pp. 1821–1830, Aug. 2004, <https://doi.org/10.1109/TPWRS.2004.835679>.
- [17] J. Che and J. Wang, "Short-term load forecasting using a kernel-based support vector regression combination model," *Applied Energy*, vol. 132, pp. 602–609, Nov. 2014, <https://doi.org/10.1016/j.apenergy.2014.07.064>.
- [18] J. Chakravorty, S. Shah, and H. N. Nagraja, "ANN and ANFIS for Short Term Load Forecasting," *Engineering, Technology & Applied Science Research*, vol. 8, no. 2, pp. 2818–2820, Apr. 2018, <https://doi.org/10.48084/etasr.1968>.
- [19] W. C. Hong, "Electric load forecasting by support vector model," *Applied Mathematical Modelling*, vol. 33, no. 5, pp. 2444–2454, May 2009, <https://doi.org/10.1016/j.apm.2008.07.010>.
- [20] E. Ceperic, V. Ceperic, and A. Baric, "A Strategy for Short-Term Load Forecasting by Support Vector Regression Machines," *IEEE Transactions on Power Systems*, vol. 28, no. 4, pp. 4356–4364, Aug. 2013, <https://doi.org/10.1109/TPWRS.2013.2269803>.
- [21] A. Selakov, D. Cvijetinović, L. Milović, S. Mellon, and D. Bekut, "Hybrid PSO-SVM method for short-term load forecasting during periods with significant temperature variations in city of Burbank," *Applied Soft Computing*, vol. 16, pp. 80–88, Mar. 2014, <https://doi.org/10.1016/j.asoc.2013.12.001>.
- [22] W. Sun, "A Novel Hybrid GA Based SVM Short Term Load Forecasting Model," in *2009 Second International Symposium on Knowledge Acquisition and Modeling*, Wuhan, China, Aug. 2009, vol. 2, pp. 227–229, <https://doi.org/10.1109/KAM.2009.31>.
- [23] A. Kavousi-Fard, H. Samet, and F. Marzbani, "A new hybrid Modified Firefly Algorithm and Support Vector Regression model for accurate

- Short Term Load Forecasting," *Expert Systems with Applications*, vol. 41, no. 13, pp. 6047–6056, Oct. 2014, <https://doi.org/10.1016/j.eswa.2014.03.053>.
- [24] M. Barman and N. B. Dev Choudhury, "Season specific approach for short-term load forecasting based on hybrid FA-SVM and similarity concept," *Energy*, vol. 174, pp. 886–896, May 2019, <https://doi.org/10.1016/j.energy.2019.03.010>.
- [25] M. Barman, N. B. Dev Choudhury, and S. Sutradhar, "A regional hybrid GOA-SVM model based on similar day approach for short-term load forecasting in Assam, India," *Energy*, vol. 145, pp. 710–720, Feb. 2018, <https://doi.org/10.1016/j.energy.2017.12.156>.
- [26] H. Lu, M. Azimi, and T. Iseley, "Short-term load forecasting of urban gas using a hybrid model based on improved fruit fly optimization algorithm and support vector machine," *Energy Reports*, vol. 5, pp. 666–677, Nov. 2019, <https://doi.org/10.1016/j.egy.2019.06.003>.
- [27] H. Jiang, Y. Zhang, E. Muljadi, J. J. Zhang, and D. W. Gao, "A Short-Term and High-Resolution Distribution System Load Forecasting Approach Using Support Vector Regression With Hybrid Parameters Optimization," *IEEE Transactions on Smart Grid*, vol. 9, no. 4, pp. 3341–3350, Jul. 2018, <https://doi.org/10.1109/TSG.2016.2628061>.
- [28] X. Wang and Y. Wang, "A Hybrid Model of EMD and PSO-SVR for Short-Term Load Forecasting in Residential Quarters," *Mathematical Problems in Engineering*, vol. 2016, Dec. 2016, Art. no. e9895639, <https://doi.org/10.1155/2016/9895639>.
- [29] Q. Chen, Y. Wu, X. Zhang, and X. Chen, "Forecasting system based on Wavelet Transform and PSO-SVM," in *Security and Identification 2008 2nd International Conference on Anti-counterfeiting*, Guiyang, China, Dec. 2008, pp. 305–309, <https://doi.org/10.1109/IWASID.2008.4688383>.
- [30] S. Qiang and Y. Pu, "Short-term power load forecasting based on support vector machine and particle swarm optimization," *Journal of Algorithms & Computational Technology*, vol. 13, Jan. 2019, Art. no. 1748301818797061, <https://doi.org/10.1177/1748301818797061>.
- [31] W. Sun and M. Ye, "Short-Term Load Forecasting Based on Wavelet Transform and Least Squares Support Vector Machine Optimized by Fruit Fly Optimization Algorithm," *Journal of Electrical and Computer Engineering*, vol. 2015, Dec. 2015, Art. no. e862185, <https://doi.org/10.1155/2015/862185>.
- [32] Z. Guo, L. Hu, J. Wang, and M. Hou, "Short-term Load Forecasting Based on SSA-LSSVM Model," in *2021 4th International Conference on Energy, Electrical and Power Engineering (CEEPE)*, Chongqing, China, Apr. 2021, pp. 1215–1219, <https://doi.org/10.1109/CEEPE51765.2021.9475790>.
- [33] J. P. Liu and C. L. Li, "The Short-Term Power Load Forecasting Based on Sperm Whale Algorithm and Wavelet Least Square Support Vector Machine with DWT-IR for Feature Selection," *Sustainability*, vol. 9, no. 7, 2017, <https://doi.org/10.3390/su9071188>.

AUTHORS PROFILE



Ngoc-Hung Duong was born in Long An, Vietnam, on December 1, 1970. He graduated from the HCMC University of Technology. He received a master's degree in major automation and control engineering at Ho Chi Minh City University of Technology (BKU) in 2016. From 2009, he was a researcher at Tien Giang University, Vietnam. Since 2017, he is a Ph.D. student in major electrical engineering at HCMC University of Technology and Education. His research interests include system modeling, forecasting load electricity, and power system control.



Minh-Tam Nguyen was born in Ben Tre, Vietnam. He received a Ph.D. degree in Engineering Science from the University of Technology, Sydney, Australia in 2010. He is the dean of the Faculty of Electrical and Electronics Engineering, Ho Chi Minh City University of Technology and Education. His research interests include system modeling, intelligent and robust control, soft computing, and power system control.



Thanh-Hoan Nguyen specializes in research on AI and ML technologies applied in load forecasting and grid analysis. He graduated from the Ho Chi Minh City University of Technology (HCMUT), under the Honor Program. He finished the Master of Telecommunication Engineering program at HCMUT. Currently, he is carrying out research for his Ph.D. He is working as a specialist at the Information Technology Company of Ho Chi Minh City Power Corporation (EVNHCMC). He has contributed to the development of data collection and mining systems, IoT Gateway application for Automatic Meter Reading (AMR), and Fault Indicators System (FI), with the application of modern technologies including Big Data, AI into the company's fields of operation.



Thanh Phong Tran was born in Tien Giang, Vietnam, on September 2, 1986. He graduated from the Vietnam National University, Ho Chi Minh City University of Technology (HCMUT). He received a National Master's Degree (DNM) in Science, Technology and Health in Complex Systems Engineering, Optimization and Safety of Systems (OSS), at the University of Technology of Troyes, France in 2011, and a Ph.D. degree in Automation and Applied Computing at the University of Angers, France in 2017. From 2011, he was a lecturer-researcher at Tien Giang University, Vietnam. Later, he was the deputy head of the Scientific Research & Technology Management and International Cooperation Office, Tien Giang University. He is also an assistant professor, at Polytech Angers, University of Angers, France from 2021. His research works are devoted to parametric identification, inverse problems, process analysis, systems control theory, renewable energy, and pattern recognition. Most of his publications are focused on nonlinear partial differential equations systems, describing the state evolution of complex thermal processes, and renewable energy generators.