

# Design of Intelligent Control Arm Strength Training Device for Students

Weiliang Ren, Guibing Liao, Fuxing Zhang, Jingtao Yang, Jiayu Li, Jie Li

Liaoning University of science and technology, China

---

**Abstract:** The design belongs to the technical field of sports training equipment, especially for the arm strength training system, including a support seat, a support rod, a holding rod and a body. The two sides of the support seat are connected with knobs through screw thread, the inner side of the support seat is clamped and connected with a support rod, and the bottom side of the support rod is fixedly connected with No. 1 fixed base, One side of the No.1 fixed base is rotationally connected with a screw rod through a rotating shaft, the upper end of the screw rod is connected with a rod groove through screw thread, the upper end of the rod groove is clamped and connected with a pull rope, the upper end of the rope is fixedly connected with a handle, and a variety of strength training structures are arranged in the training device, It can carry out a variety of arm strength training exercises, and can carry out complete and comprehensive training on arm strength, wrist strength, biceps and triceps and other muscle groups, with good training effect and comprehensive training.

**Keywords:** Intelligent control; Exercise; Arm; Strength training device.

---

## 1. Preface

The arm refers to the upper limb, the part below the shoulder and above the wrist, sometimes including the hand. Physical exercise is a physical activity process with the purpose of developing the body, improving health, strengthening the physique and entertaining the body and mind by using various sports means and combining with natural forces. It is the main form of mass sports activities, which can promote the growth and development of the human body, cultivate the body-building posture and improve the working ability of the body, According to the characteristics of people's age and occupation, exercise can be carried out in a variety of ways, which can improve people's physical fitness and mental health, In addition to the common practice methods in teaching and training (including repetition method, transformation method, comprehensive method, circulation method and competition method), people have formed various fitness methods in long-term exercise practice.

The arm strength training system controlled by computer can monitor and count the trainers in the training process through the computer control system. During the use of the arm strength training device, only a single way of arm strength training can be carried out, and the complete and comprehensive training of arm strength, wrist strength, biceps and triceps muscles and other muscle groups cannot be carried out, and the training effect is not good, The training function is single; In the process of using arm strength training device, unreasonable placement, inconvenient folding, occupying large space, easy to collide with objects, and in the process of arm strength training, the tension adjustment of the training device is inconvenient, which can not meet various training needs, and the scope of application is narrow.

## 2. Design Content

In order to solve the above problems existing in the existing technology, the design provides an arm strength training system, which has the characteristics of easy adjustment and

easy retraction.

In order to achieve the above purpose, the design provides the following technical scheme: arm strength training system, including a support seat, a support rod, a holding rod and a body. The two sides of the support seat are connected with knobs through screw thread, the inner side of the support seat is clamped and connected with a supporting rod, and the bottom side of the support rod is fixedly connected with a fixed seat No. 1, One side of the No. 1 fixed base is rotationally connected with a screw rod through a rotating shaft, the upper end of the screw rod is connected with a rod groove through screw thread, the inner surfaces of the upper and lower ends of the rod groove are clamped and connected with a connecting block, the connecting blocks are connected with each other through a spring, the upper end of the rod groove is clamped and connected with a pull rope, and the upper end of the pull rope is fixedly connected with a handle, The inner surface of the upper end of the grip is provided with a spring groove, the inner surface of the bottom end of the elastic groove is elastically connected with a spring block, the upper end of the support rod is fixedly connected with a connecting seat, both sides of the connecting seat are connected with holding rods through the screw connection, the upper end of the connecting seat is connected with a rotating plate through a rotating shaft, and one side of the rotating plate is arranged on the wall surface.

The upper end of the support seat is an arc-shaped structure and fits with the support rod, and the bottom end of the support seat is a square structure and fits with the ground surface.

The optimal technical scheme of the arm strength training system is that the central positions of both sides of the support seat are fixedly connected with No. 1 stop block, and the No. 1 limit block is of square structure.

The optimal technical scheme of arm strength training system is that one side of the bottom end of the screw rod is fixedly connected with a tension spring, and the screw rod is elastically connected with the surface of the bottom side of the support rod through the tension spring.

The optimal technical scheme of arm strength training

system is that one side of the upper end of the support rod is fixedly connected with a No. 2 fixed base, and one side of the No. 2 fixed base is fixedly connected with a hook, and the hook is of arc structure.

The technical scheme of the arm strength training system is optimized, and the grip rod is of column structure, and the outer periphery is sheathed with a rubber sleeve.

The optimal technical scheme of the arm strength training system is that the central position of one side surface of the connecting seat is fixedly connected with No. 2 limiting block, which is of square structure.

### 3. Specific Implementation Mode

In the following, the technical scheme in the embodiment of this design will be described clearly and completely in combination with the attached drawings in the design embodiment. Obviously, the described embodiments are only part of the embodiments of the design, not all the embodiments.

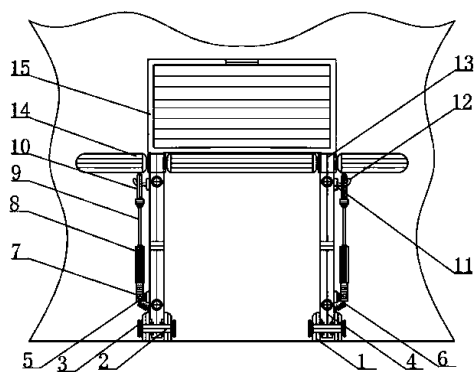

Figure 1. Shows the structure of the design

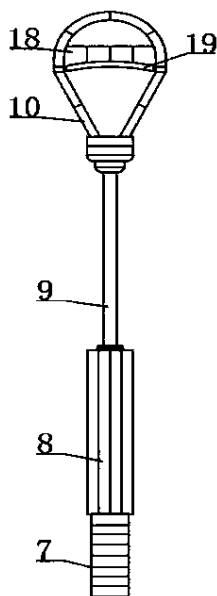

Figure 2. Is the schematic diagram of the side view connection structure of the pulling rope in this design

In the picture: 1;2. No. 1 limit block;3. Knob;4. Supporting rod;5. No. 1 fixed base;6. Tension spring;7. Screw rod;8. Rod groove;9. Pulling rope;10. Grip;11. No. 2 fixed base;12. Hook;13. Connecting base;14. Holding rod;15. Rotating plate;16. Organism;17. No. 2 stop block;18. Bullet slot;19. Bullet block;20. Connection block.

Please refer to Figure 1-2. This design provides the following technical solutions: arm strength training system,

including support seat, support rod, grip rod and body. Both sides of the support seat are connected with knobs through screw thread, the inner side of the support seat is connected with a support rod, the bottom side of the support rod is fixedly connected with No. 1 fixed seat, and one side of the No. 1 fixed base is connected with a screw rod through a rotating shaft, The upper end of the screw rod is connected with a rod groove by screw thread, the inner surfaces of the upper and lower ends of the rod groove are clamped and connected with a connecting block, the connecting blocks are connected with each other by springs, the upper end of the rod groove is clamped and connected with a pull rope, the upper end of the pull rope is fixedly connected with a grip, the inner surface of the upper end of the grip is provided with a spring groove, and the inner surface of the bottom end of the spring groove is elastically connected with a spring block, The upper end of the supporting rod is fixedly connected with a connecting seat, both sides of the connecting seat are connected with a holding rod through a rotary shaft, the upper end of the connecting seat is connected with a rotating plate through a rotating shaft, and one side of the rotating plate is arranged with an organism. In this embodiment, the support seat is made of metal material, which is used for the fixation and support of the training device as well as the rotation and adjustment of the support rod. The support rod is made of metal, It is used to fix and support the whole training device, and the knob is used to adjust the rotation angle of the supporting rod. Please refer to the operation process for the specific use method. The No. 1 fixed base is connected with the screw rod through the rotation shaft, which is used for the rotation of the screw rod and the rod groove. The screw rod is made of metal material, which is used to connect the rod groove and adjust the tension of the pulling rope. Please refer to the operation process for the specific use method, the upper end is connected with the upper end of the tension rod and the lower end is connected with the upper and lower ends of the tension rod, the grip is made of plastic material, which is used for arm strength training by pulling a pull rope. One end of the spring groove is connected with one end of the elastic block through a spring. The spring groove, spring block and spring structure are used for arm wrist strength training. The connecting seat is used to connect the grip rod and the rotating plate. The rotating plate is made of plastic material, and the rotating plate is used to place the training items and computers. The computer is the body, the body is set on the wall, through which the relevant training and teaching video files can be played. At the same time, the training process can be monitored and counted by sensors and counters.

The upper end of the support seat is an arc-shaped structure and fits with the support rod, the bottom end of the support seat is a square structure and fits with the ground surface. In this embodiment, the support seat is made of metal material and is fixedly connected with the wall surface by bolts. The upper end of the support seat is an arc-shaped structure and fits with the support rod. The bottom end of the support seat is a square structure and fits with the ground surface, the support seat is used to fix and support the whole training device, as well as the rotation and adjustment of the support rod. Slightly rotate the knobs on both sides of the support seat outwards. The end of the knob and the support rod are separated from each other, and the extrusion force disappears. The support rod is in an active state. Pull the support rod and grip rod outward, and the support rod and grip bar rotate outward, one side of the bottom end of the support rod fits

with the No. 1 stop block at the center of the surface of one side of the support seat, and the No. 1 stop block supports and limits the support rod.

No. 1 limit block is fixedly connected at the central position of the surface of both sides of the support seat, and the No. 1 limit block is of square structure. In this embodiment, the No. 1 limit block is made of metal and is arranged on both sides of the support seat, which is used for the rotation limit and support of the support rod. The knobs on both sides of the support seat are slightly rotated outward, and the contact end of the knob and the support rod are separated from each other, and the extrusion force disappears, the supporting rod is in an active state, and the supporting rod and the holding rod are pulled outwards, and the supporting rod and the holding rod rotate outwards. One side of the bottom end of the support rod fits with the No. 1 stop block at the center of the surface of one side of the support seat, and the No. 1 stop block supports and limits the support rod.

In this embodiment, one end of the tension spring is connected with the bottom end of the screw rod, and the other end of the tension spring is fixedly connected with the bottom end of the supporting rod. The tension spring is used for the elastic stretching of the screw rod and the rod groove. After the screw rod and rod groove are used, the elastic stretching ability of the tension spring can be passed, the driving screw rod and the rod groove can quickly and better separate and retract one side of the supporting rod, saving time and labor.

One side of the upper end of the support rod is fixedly connected with No. 2 fixed base, one side of the No. 2 fixed base is fixedly connected with a hook, and the hook is of arc structure. In this embodiment, the hook is made of metal material, one end of the hook is connected with the grip, and the square structure of the other end of the hook is fixedly connected with the No. 2 fixed base, and the hook is used to place the grip, Remove the grip from the hook on one side of the upper end of the support rod, connect the hand with the arc-shaped groove at the rear end of the grip, pull the handle to one side, rotate the screw rod and rod groove through the rotating shaft of No. 1 fixed base, turn the screw rod, rod groove, pull rope and grip to the front end, face the trainer, and stand at the center of the front end of the training device.

In this embodiment, the grip rod is made of metal material and is divided into three sections, which are respectively arranged at the left, middle and right positions of the connecting seat through the rotary connection. The rubber sleeve is sheathed around the outside of the grip rod, which is convenient for grasping the grip rod, comfortable to hold and not easy to slide. The grip rod is mainly used for push up exercise, and can be used for wide distance, wide range, and high-speed Middle and narrow pushups.

The second limit block is fixedly connected at the central position of one side surface of the connecting seat, and the second limit block is of square structure. In this embodiment, the second limit block is made of metal and square structure, and is located at the center of the back surface of the connecting seat. The second limit block is used for supporting and limiting the rotary plate. During the process of lowering the rotating plate, it rotates through the rotating shaft at the connection between the bottom end of the rotating plate and the connecting seat, the rotating plate is turned to the bottom side, and the rotating plate is placed vertically with the wall. The bottom end of the rotary plate is connected with the No. 2 limit block at the center of the surface of one side of the connecting seat. The No. 2 limit block supports and limits the

rotary plate.

## 4. Design Principle

The working principle and application process of this design: when the design is in use, the knobs on both sides of the support base are slightly rotated outward, the contact end of the knob and the support rod are separated from each other, and the extrusion force disappears. The support rod is in an active state. Pull the support rod and grip rod outward, and the support rod and grip rod rotate outward, and the bottom side of the support rod fits with the No. 1 limit block at the center of the surface of one side of the support seat, No. 1 limit block supports and limits the supporting rod. The supporting rod and the holding rod are inclined at a certain angle, and the knobs on both sides of the support base are slightly rotated inward. The end of the knob and the support rod are squeezed each other, and the support rod is in a fixed state. The rotating plate at the upper end of the connecting seat is put down to fit the wall surface, the rotating shaft at the connection between the bottom end of the rotating plate and the connecting seat is rotated. The rotating plate turns to the bottom side, and the rotating plate is placed vertically with the wall. The bottom end of the rotating plate is connected with the No. 2 limit block at the center of the surface of one side of the connecting seat. The second limit block supports and limits the rotating plate. The rotating plate is used to place the training items and computers. The computer is the body to start the body and work, Remove the grip from the hook on one side of the upper end of the support rod, connect the hand with the arc groove at the rear end of the grip, pull the handle to one side, rotate the screw rod and rod groove through the rotating shaft of No. 1 fixed base, turn the screw rod, rod groove, pull rope and grip to the front end, face the training personnel, stand at the center of the front end of the training device, and play the relevant training and teaching video files through the body, At the same time, the sensor and counter can monitor and count the trainers in the training process. Both hands pull the pull rope through the grip. The pull rope moves up and down in the rod groove and the upper end of the rod groove through the connecting block and the spring connected between the connecting block and the connecting block at the bottom end of the rod groove. Through elastic stretching, the arm muscle strength is trained. When the pull rope tension needs to be adjusted, the rod groove is rotated downward, It can be connected with the upper part of the screw rod by pulling the lower elastic force and groove between the screw rod and the upper part of the screw Rodin the middle distance and narrow distance push-up training, the hand can be held on the spring slot in the middle of the handle, and the hand fits with the spring block. By holding the elastic block before and after, the elastic block can stretch and stretch through the spring inside the spring groove to exercise the arm wrist force.

## 5. Conclusion

Compared with the existing technology, the design features: a variety of strength training structures are set in the training device, through the structure of holding rod, supporting rod, screw rod, rod groove, grip, spring groove and spring block, various arm strength training methods can be carried out, and complete and comprehensive training of arm strength, wrist strength, biceps and triceps and other muscle groups can be carried out, and the training effect is good, Comprehensive training; The arm strength training device is designed as a

wall mounted training device. Through the fixed structure, rotation structure and adjustment structure, the training device can be folded and retracted very well. It is easy to use and easy to retract. Moreover, the spring tension can be adjusted through the screw rod and rod groove rotation structure to meet the needs of most people.

## Acknowledgment

Funded by Liaoning University of science and technology 2022 innovation and entrepreneurship training program.

## References

- [1] A hand tendon rupture rehabilitation training device [P]Li Jianfeng, Zhang Kewei, Liang Kangxiong, Qiu Lili, Gaoyang, an Hengjie, Wang WeichengChinese patent: cn214909038u, 2021-11-30
- [2] A wheelchair with rehabilitation training function [P]Jiang Ge, Lu Zuquan, Liu Fuqing, Cai Qinmin, Yu tianshuaiChinese patent: cn210542122u, 2020-05-19
- [3] A kind of hospital bed convenient for rehabilitation exercise [P]Chen YifanChinese patent: cn211244183u, 2020-08-14
- [4] A rehabilitation training device [P]Deng zesongChinese patent: cn108836737b, 2020-11-17
- [5] The utility model relates to a leg rehabilitation training device for senile diseasesZhao Xiuling, Cao Lu, Li caidiChinese patent: cn213218125u, 2021-05-18
- [6] A traditional Chinese medicine rehabilitation training device [P]Xue JunminChinese patent: cn213697449u, 2021-07-16
- [7] The utility model relates to a multifunctional hand rehabilitation training device for stroke shoulder hand syndrome [P]Cheng Ruidong, ye XiangmingChinese patent: cn215535516u, 2022-01-18