

Design of a Logistics Management System Based on QT

Hongyan Zhang¹ and Bing Zhang²

¹ School of Mechanical and Electrical Engineering, Jilin of Chemical Technology University, Jilin Jilin 132022, China

² School of Information and Control Engineering, Jilin of Chemical Technology University, Jilin Jilin 132022, China

Abstract: Based on QT and GD32F103, this paper designs a logistics management system to enable express delivery personnel to remotely obtain the parameters of express deliveries and make timely decisions. The real-time information of express deliveries is collected by a camera and transmitted to the QT end through the UVC protocol. The parsed data is then stored on a cloud server through QT. This system combines user interface design and embedded system technology to achieve the monitoring and sorting of express deliveries.

Keywords: Logistics; GD32F103; QT; Cloud Server.

1. Introduction

With the development of the logistics industry, the volume of express delivery is growing rapidly, and the traditional logistics mode is difficult to meet the current demand for efficient and accurate express delivery. In order to improve the intelligent level of logistics, reduce labor costs, and to achieve the efficient and accurate needs of express sorting, it is particularly important to develop a logistics management system based on modern information technology. This paper presents a design scheme of logistics management system based on Qt.

This system uses GD32F103 single chip microcomputer as the core chip, uses imx291 camera module, takes real-time photo processing of express side order, and transmits data to Qt terminal through UVC protocol. As a user interface, Qt is responsible for data display and access to the cloud platform to achieve data storage and remote access [1]. The system realizes the automatic sorting and pushing of the express through the cooperation of the biphas motor and the steering gear. This system is designed by combining user interface design, embedded system development technology and cloud computing technology, which can provide remote monitoring for delivery personnel and improve the intelligent level of logistics.

2. Hardware Design

2.1. 3200 IMX291 Camera Module

This design uses 3200-imx291 camera module, which can better collect the express invoice data. The module supports a speed of 30 frames per second and features automatic exposure and automatic white balance. Using the automatic white balance method to process the single photo of express can improve the quality of the picture. The module communicates directly with the computer through the USB2.0 drive freeway. When the express enters the system, the module transmits the acquired image data to the QT side through the UVC protocol, and then identifies the express bill and extracts the key information of the express bill (such as bar code, address, etc.).

Qt side uploads data to Ali intelligent cloud platform through MQTT protocol. In the process of data transmission, this design uses encryption technology to encrypt the data to ensure the security of the data in the transmission process.

After the data is stored in the cloud platform, the Courier can access and monitor the express information in real time through the Qt interface, and the system supports the backup and recovery function of the data to deal with the possible network failure or data loss in the future.

2.2. MG996 Servo Module

This design uses MG996 steering gear module to launch the express package. The MG996 steering gear module is controlled by PWM (pulse width modulation) signals. The period of the control signal is 20ms, and the pulse width varies between 0.5ms and 2.5ms, corresponding to the Angle of the steering gear from 0° to 180 [2]. A pulse width of 0.5ms can turn the steering gear to the 0° position, a pulse width of 1.5ms can turn the steering gear to the 90° position, and a pulse width of 2.5ms can turn the steering gear to the 180° position.

The actuator module is connected with the corresponding pin of GD32F103 single chip computer through signal line, ground line and power line to realize communication and control. GD32F103 generates PWM signals according to the instructions of the system, and precisely controls the Angle of the steering gear by adjusting the pulse width, so as to realize the launch of express packages. The internal circuit design of MG996 steering gear is shown in Figure 1. The internal circuit of the steering gear module includes motor drive circuit, control circuit and feedback circuit, which work together to ensure that the steering gear can accurately adjust the Angle according to PWM signal.

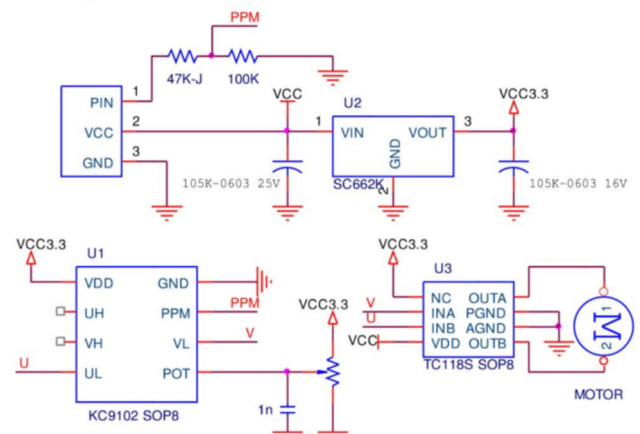

Fig 1. MG996 servo circuit diagram

2.3. A4988 Motor Driver Module.

Do not number your paper: All manuscripts must be in English, also the table and figure texts, otherwise we cannot publish your paper. Please keep a second copy of your manuscript in your office. When receiving the paper, we assume that the corresponding authors grant us the copyright to use the paper for the book or journal in question. Should authors use tables or figures from other Publications, they must ask the corresponding publishers to grant them the right to publish this material in their paper. Use italic for emphasizing a word or phrase. Do not use boldface typing or capital letters except for section headings (cf. remarks on section headings, below).

This design uses A4988 motor drive module to drive the two-phase stepper motor. The A4988 module receives the low current signal from the GD32F103 microcontroller and amplifies it into the high current signal required by the motor, thus achieving precise control of the motor. The module has the characteristics of high performance micro step control, high drive ability, easy to use and integration. The module supports a variety of micro-stepping modes, including full step, half step, 1/4 step, 1/8 step and 1/16 step. This micro-stepping capability can significantly reduce the vibration and noise of the motor. Through micro-stepping control, the motor is more stable at low speed, thus avoiding the jitter problem caused by excessive stepping [3].

The current converter built into the module is the core of simple applications and is able to convert pulse signals into current control signals for high-precision motor motion control. The module is also equipped with an internal synchronous rectifier control circuit that optimizes power consumption under pulse width modulation (PWM) operation. The module also has complete circuit protection functions, such as undervoltage lock overheat protection and cross current protection, which can effectively prevent motor current spikes and voltage anomalies from damaging the microcontroller.

The module communicates with GD32F103 through serial port, and connects the sending pins TX and receiving pins RX of the module to the serial pins of GD32F103 to achieve stable data transmission and control [4]. The circuit design of the A4988 module includes a current amplification circuit, a microstepping control circuit and a protection circuit, which work together to ensure that the motor can operate precisely according to the pulse signal.

3. Software Design

The software design of this system is divided into embedded software design and upper computer software design two parts. The embedded software runs on GD32F103 MCU and is responsible for the interaction and data processing with the hardware module. The upper computer software is developed based on Qt framework, provides user interaction interface, and realizes data storage and remote monitoring through cloud platform [5].

3.1. A4988 Motor Driver Module.

When the system is powered on, the initialization procedure of the system clock, timer, serial communication, I2C interface, motor module and steering gear module is executed first. After the initialization operation is completed, the system enters the main loop and completes the next instruction. The embedded software runs on GD32F103 MCU

and is responsible for the interaction and data processing with the hardware module. The software design adopts modular programming idea, which is divided into the following key modules:

3.1.1. System Initialization Module

The system initialization module initializes hardware resources, including the system clock, serial communication, timer, I2C interface, motor module, and steering gear module. System clock configuration ensures that the system is running at the correct clock frequency; The initial configuration of serial communication parameters, such as baud rate, data bit, stop bit, etc. for data transmission with the host computer; Timer initialization is used for timing tasks and interrupt processing. I2C interface initialization is used to communicate with external devices. The motor module initially configures the parameters of the motor driver to ensure the normal operation of the motor; The actuator module initially configures the parameters of the PWM signal to precisely control the Angle of the actuator. After the initialization is complete, the system enters the main loop and waits to receive instructions from the upper computer.

3.1.2. Motor and Servo Control Module

The motor and steering gear control module controls the speed of the motor and the Angle of the steering gear according to the instructions sent by the upper computer. The module first analyzes the instructions sent by the host computer and extracts the parameters of motor speed and steering gear Angle. Parse_MotorSpeed, the function of analyzing the motor speed instruction, extracts the speed parameters, and sets the motor speed through the Motor_SetSpeed function to ensure the smooth operation of the motor. Parse_ServoAngle, the function of analyzing the Angle instruction of the steering gear, extracts the Angle parameters, and sets the Angle of the steering gear through the Servo_SetAngle function to ensure that the steering gear can be accurately controlled. In this way, the module implements the sorting and push operation of the express.

3.1.3. Serial Communication Module

Serial communication module is responsible for data transmission between embedded system and host computer. The module initializes serial port parameters, including baud rate, data bit, and stop bit, to ensure data transmission reliability. Enable the serial port receiving interrupt to receive data from the host in time. When data is received, the callback function USART_Receive is triggered to process the received data. Callback functions call processing functions based on the data type, such as parsing instructions or updating the system state. Data is sent to the host computer through the USART_Transmit function to ensure the integrity of data transmission. In this way, the module realizes the efficient communication between the embedded system and the host computer.

3.2. A4988 Motor Driver Module.

On the Qt graphical interface development platform, the application program is developed through C++ language, and it is connected to Ali Cloud platform to realize the interaction of data. And remote control. In the development process, the MQTT protocol package is imported into the Qt application to realize the connection with Ali intelligent cloud platform. By subscribing to related topics, the application is able to receive data from the cloud. Using Qt's signal and slot mechanism, when data arrives, the system triggers slot

function to complete data processing and interface update [6].

The design part of the Qt interface provides user interactive experience, and the functions to achieve include: the entry of express information, users can enter the relevant information of the express sender through the interface, the relevant information of the recipient, the address, the weight and other content. The system will verify the integrity and accuracy of the input information. After the information is correct, a pop-up message indicating that the input is successful. Control of sorting operation, the user can select the destination of express sorting through the interface, and start the sorting operation by clicking the "sorting" button. The system will control the steering gear and motor module according to the selected target address, and push the delivery to the specified location. Real-time monitoring and feedback, the interface displays the current status of the express in real time (such as entered, sorting, sorting completed, etc.), and prompts the user's operation results through the pop-up window. The system also provides a historical record query function, which facilitates the Courier to trace the processing process of the express.

The upper computer software is developed based on Qt framework, provides user interaction interface, and realizes data storage and remote monitoring through cloud platform. Software design is divided into the following key modules:

3.2.1. Qt interface design

The Qt section provides an intuitive user interaction. The main window class MainWindow is responsible for initializing the interface and handling user actions. When a user clicks the Connect button, the onConnectButtonClicked function is triggered to connect to the cloud platform. User input data is sent to the embedded system via the onSendButtonClicked function. The data received from the embedded system is processed by the onReceiveData function and the interface display is updated. The interface includes express information input, sorting operation control, real-time monitoring and feedback. Users can enter the sender information, recipient information, address, weight and other content through the interface. The system will automatically verify the integrity and accuracy of the input information. After the information is correct, a dialog box will be displayed to inform the user that the input is successful.

3.2.2. Cloud platform communication module

The cloud platform communication module is responsible for establishing a connection with Ali Intelligent cloud platform to achieve data upload and download. CloudPlatform is responsible for the interaction with cloud platforms. The connectToCloud function connects to the cloud platform and configures the connection parameters. The uploadData function uploads data to the cloud platform to ensure the security of data transmission. The downloadData function downloads data from the cloud platform to ensure the integrity of the data received. Messages received from the cloud platform are processed by the onMessageReceived function and the interface display is updated. In this way, the module achieves efficient communication with the cloud platform.

3.2.3. Data Processing Module

The data processing module is responsible for processing the raw data received from the embedded system and extracting key information. The data processing class DataProcessor is responsible for data processing. The processData function processes the raw data and extracts the

key information. The extractKeyInfo function uses regular expressions or specific algorithms to parse data and extract key information such as bar codes and addresses. The processed data is stored in the cloud platform for real-time monitoring and query by Courier personnel.

4. System Functionality Testing

When the GD32F103 is powered on, start the QT application. Enter the login information on the QT side to complete the connection with Ali intelligent cloud platform. After the device is successfully connected to the cloud platform, the QT side can display the entered express related information in real time [7]. As shown in Figure 2, it is the input system of express delivery. After scanning the code, you can enter the mailing address and receiving address. If the input information is correct, the automatic pop-up window will indicate that the input is successful. As shown in Figure 3, logistics management system, select shipment, check the address, the system will automatically push out the corresponding express, after the end, the system pop-up window prompts the end of shipment. The running interface shows the real-time status of the system, including the current status of the express (such as entered, sorting, sorting completed, etc.), the network connection status and the running status of the hardware module.



Fig 2. Logistics management system entry interface



Fig 3. Logistics management system operation interface

In order to verify the reliability of the system, the normal operation test and abnormal test are carried out.

Under normal network and hardware conditions, the system's input function, sorting and monitoring functions are tested. The test results show that the system can run stably. The system is tested for fault tolerance and resilience under simulated network failures, hardware failures and abnormal inputs. The test results show that the system can upload the

cache data after the network recovery, and the hardware fault alarm mechanism can respond.

5. Summary

After several rounds of debugging and optimization, the system realizes the function of collecting data from the camera module and transmitting it to the QT side for display, and can manipulate the motor to selectively launch the required express on the Qt side. By using the open source Qt framework and hardware modules, the cost of the system is reduced. This system realizes the high efficiency of logistics system by realizing real-time data collection and processing. This system also designed the network fault tolerance mechanism, hardware fault alarm mechanism and exception processing mechanism to improve the reliability of the system. Through the combination of cloud platform and Qt interface, Courier personnel can monitor express status and remote operation, improving the intelligent level of logistics management.

In the future, we will continue to optimize system functions, introduce embedded alternatives, transplant Qt to embedded platforms, and directly integrate modules and controllers such as cameras to form an integrated device. A centralized processing approach will be adopted, with a single high-performance host connecting multiple cameras and controllers through multi-USB expansion to further enhance the automation of the system.

Acknowledgments

Jilin Province Department of Education industrialization cultivation project+JJKH20240313CY.

References

- [1] Chen Dongling. Design of indoor environment monitoring system based on Qt and Wi-Fi [J]. Information Technology and Informatization, 2019, (11): 22-25.
- [2] Ning Chunlei, Liu Fanqi, Sun Zaishang. Design of multi-degree of freedom manipulator based on STM32 [J]. Electronic World, 2017,(09):143.
- [3] LAN Jie, Zhang Haoran. Design of Micro Stepper Motor Drive Controller Based on STM32 [J]. Micromachines and Applications, 2015,34(01):43-46.
- [4] Du Xinkai, Wei Wen, Zhao Zhan. Design and implementation of Smart Home Control System based on STM32 [J]. Electronic Production,2023,31(23):15+29-32.
- [5] Yang Zhuofan, Li Lin. Design and implementation of Intelligent Express Delivery System based on STM32 and Cloud Platform [J]. Electronic Production, 2019,32(19):28-30+77.
- [6] Mei Xinyuan, Hou Zhesheng. Design of Medical Remote Monitoring System based on QT and STM32 [J]. Industrial Control Computers,2024,37(09):159-160.
- [7] LI Zengliang, Xu Song, Yan Liqiang, Hu Peng. Design of Shield Pump Remote Monitoring System based on embedded and Qt [J]. Instrument User,2021,28(09):10-14.