

Design and Testing of a Soil Inversion and Mulching Machine

Long Zhang, Zhesheng Hou

School of Jilin University of Chemical Technology, Jilin Jilin, 132022, China

Abstract: In order to address the problems of low water resource utilization and easy soil structure damage in traditional irrigation techniques for vegetable cultivation, and to promote the mechanized application of water-saving film laying technology, this paper designs a multifunctional soil turning and film covering machine based on UG software that can complete rotary tillage, film covering, and soil covering operations at once. Optimize the design of rotary tillage, soil throwing, compaction and mulching mechanisms. Conduct tests on clay soil blocks in accordance with relevant standards to evaluate their performance in terms of soil turning, mulching, covering quality, and operational efficiency. The results show that the machine meets the agronomic requirements.

Keywords: Rotary Tillage for Soil Throwing; Film Covering; UG; Compaction for Soil Covering.

1. Introduction

The total amount of freshwater resources in China is about 2.8 trillion cubic meters, accounting for 6% of the global water resources and ranking fourth among countries in the world. However, on a per capita basis, the annual runoff per person is only 2670 cubic meters, which is only 1/4 of the world average, making it one of the countries with the poorest per capita water resources in the world[1]. Developing countries account for 72% of the world's total vegetable production, and vegetables play an important role in human diets, especially in developing countries such as China and India. In 2000, the global per capita vegetable consumption was 101.9 kg per person per year. The highest consumption in developing countries in Asia is 116.2kg per person per year; South America has the lowest consumption at 47.8 kg/person • year, while Africa has 52.1 kg/person • year[2]. China's vegetable planting area and yield rank first in the world, and vegetables have become a pillar industry for increasing farmers' income.

The traditional irrigation technology has a water resource utilization rate of only 30% -50%. A large amount of water is

lost due to evaporation and leakage, and long-term use can damage the soil structure, leading to soil compaction, decreased air permeability, and affecting the development of vegetable roots[3]. The water-saving membrane laying technology can alleviate this problem by covering the soil with biodegradable geotextile, which can retain water and suppress grass. The membrane also contains crop nutrients and slows down temperature loss. Paired with a soil turning and film covering machine, it can improve vegetable yield and quality, reduce pests and diseases and costs, and increase farmers' income[4]. This machine is also suitable for planting some crops.

2. Structural Composition and Working Principle

2.1. Structural Composition

This machine is mainly composed of a frame, a soil turning mechanism, a film covering mechanism, a conveying mechanism, and a compaction and covering mechanism. As shown in Figure 1.

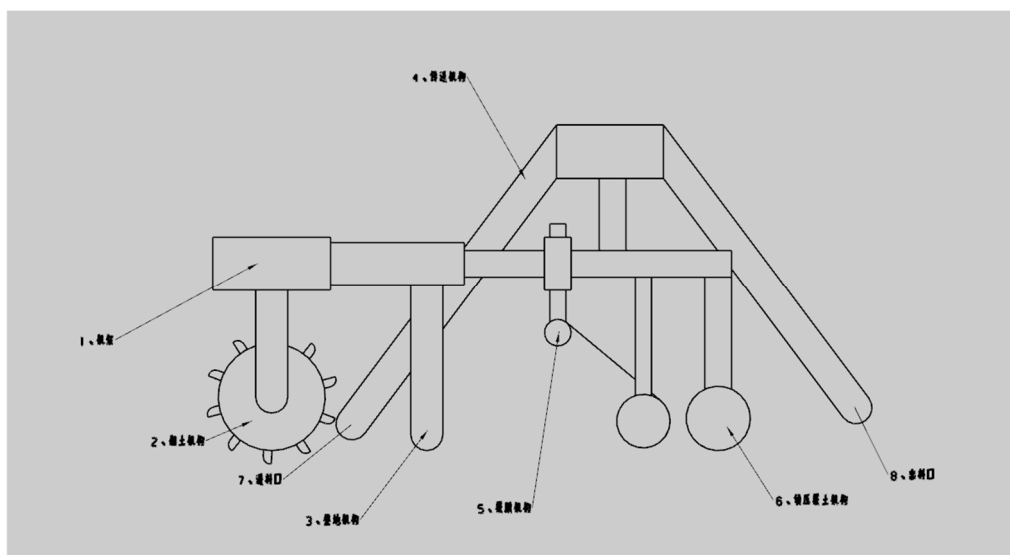

Figure 1. Schematic diagram of the switchboard structure

The soil turning mechanism: This part is located at the front end of the machine frame and consists of double layered rotary tillage wheel hubs, with multiple rotary tillage tools arranged in a staggered manner on the wheel hub, set at different heights to meet production needs, and fixed to the front end of the machine with nuts; The land preparation mechanism consists of a whole floor; Film covering mechanism: This part is divided into a film carrying platform and a film laying platform. The film carrying platform is used to place spare films, which can be replaced on the vehicle when the films are used up. The film laying platform is an adjustable laying mechanism that can control the height of the film covering by adjusting the bolts. The conveying mechanism is composed of a screw lifting belt, which can recover the flipped soil onto the film; Suppressing soil covering mechanism: consisting of two film covering wheels located on both sides of the frame, it can complete the soil covering work on the film.

2.2. Working Principle

The suspension device of the tractor is connected to the suspension frame of the machine through a rear three-point suspension. The rear power output shaft of the tractor drives the central transmission box to drive the soil turning mechanism and the conveying mechanism through a universal transmission shaft, completing tasks such as rotary tillage, soil extraction, and soil transportation; At the same time, the film covering mechanism completes the film laying operation, and the compaction and soil covering mechanism completes the film planting and soil covering operation. During operation, the tractor pulls the equipment forward, and the soil turning mechanism throws the soil backward towards the conveying mechanism. Larger soil blocks are intercepted by fences and fall onto the surface, which is then sorted by the soil sorting mechanism to improve the effectiveness of subsequent membrane laying operations; Smaller soil blocks and fine soil enter the conveying mechanism and are transported above the film covering mechanism. When working on the membrane laying mechanism, cover the soil inside the conveying mechanism onto the membrane, and finally press and compact the soil covering on both sides of the membrane of the covering mechanism.

3. Main Parameter Selection and Component Design

3.1. Selection of Main Parameters for Soil Turning Mechanism

Table 1. Main Parameters for Soil Turning Mechanism

project	unit	parameter
matching power	Kw	≥ 75
Overall dimensions	mm	2100×2470×1000
connection method		Three-point suspension
total machine weight	Kg	550
film width	cm	200
number of lines of homework	line	7
productivity	hm ² / h	0.3-0.5
Rotary tillage depth	cm	10-20
Homework speed	km / h	3-5

3.2. Selection of Main Parameters for Rotary Tillage and Soil Throwing Mechanism

3.2.1. Selection Of Plowing Depth and Plowing Width

Cultivation depth: For micro working crops such as rice, the cultivation depth can be adjusted according to the agronomic requirements and soil conditions of rice cultivation. A deeper rotary tillage depth is beneficial for improving soil structure, increasing soil permeability and water retention, but it also increases the workload and energy consumption of machinery. Determine the tillage depth of the machinery to be within 10-20cm.

The selection logic for rice cultivation width is to match the width according to the maximum power of the agricultural machinery, while also meeting the integer multiple of agronomic row spacing. This machine uses a 70 horsepower tractor and a 2.1-meter rotary tiller. The row spacing for transplanting rice seedlings is 30cm, and the tillage width is set to 2.1 meters (30cm x 7 rows, suitable for 7 rows of rice transplanters). During operation, adjacent widths overlap by 10cm to avoid missed tillage. Determine the tillage width of the machinery to be 2.1m.

3.2.2. Selection and Arrangement of Cutting Tools

Choose based on soil texture and job requirements. This article uses a 45 ° bent blade made of 65Mn spring steel with a hardness of HRC50-55 to ensure the wear resistance and strength of the blade. This design features rotary tillage for soil throwing and rear fine soil crushing for soil throwing, using a working mode of front axle forward rotation and rear axle reverse rotation. The specific plan is shown in Figure 2

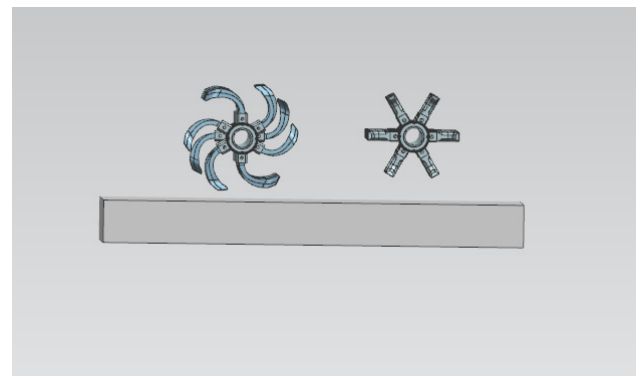

Figure 2. Dual axis soil turning mechanism

3.2.3. Selection of Speed Parameters

The speed parameters of rotary tillage film mulching machine are the core indicators that affect the work quality (soil fragmentation rate, film mulching flatness), work efficiency, and power matching, mainly including the forward speed of the machine (work speed) and the rotational speed of the rotary tillage blade shaft. In order to improve the operational efficiency and quality of the rotary tillage and soil throwing mechanism, the current high-power wide width multi-purpose rotary tiller has a blade roller speed of 250-340r/min and an operating speed of 3-7km/h. The speed parameter selection of the rice rotary tillage film mulching machine prioritizes agronomic quality, while balancing efficiency and power matching. This design includes the function of crushing and throwing soil. Therefore, to ensure the completion of the soil throwing operation, the walking speed of this machine is determined to be 3-5km/h. The speed of the rotary tiller roller is 280r/min. The speed of the soil

crushing blade roller is the same as that of the rotary tillage blade roller.

3.2.4. Selection of Supporting Power

Calculation of rotary tillage power consumption

To predict the power consumption of rotary tillage, scholars at home and abroad have conducted extensive research and proposed analytical methods such as unit method, energy method, and specific power method [5]. First, use the formula for calculating the power consumption of rotary tillage

$$P_1 = \frac{kBHv\lambda}{60\eta_1} \quad (1)$$

In the formula, K is the specific resistance of rotary tillage, N/cm², Due to the soil being sticky loam, with a plowing depth of 12-15cm and a moisture content of less than 20%, it is usually taken as 11-15N/cm²; B is the working width, m; H is the working depth, taken as 15cm, and is the rotation coefficient of the blade roller, usually taken as 1.1-1.3. In this article, it is taken as 1.2, and the transmission efficiency of rotary tillage is taken as 0.9;

Calculation of power consumption for soil fragmentation.

The overall force of the soil crushing blade roller is obtained by superimposing the force vectors of all individual soil crushing blade teeth involved in soil crushing.

The calculation formula for the body is [6]

$$P_2 = \frac{\omega BHv\gamma K}{3.6 \times 10^3 \eta_2} \quad (2)$$

ω is specific energy for soil fragmentation, kJ/kg ; γ soil bulk density, kg/m^3 .

$$\frac{P_1}{P_2} \approx 1.5 \quad (3)$$

Assuming the power consumption loss of the two blade rollers is ignored, the overall power consumption.

Therefore, the tractor power should be greater than 75KW.

3.3. Design of Soil Suppression and Covering Mechanism

This institution consists of a U-shaped Spring bolt locking device, a suppression wheel suspension plate, a suppression wheel compression spring, a suppression wheel, a soil cover plate, a soil cover plate compression spring, and an adjustable card cylinder.

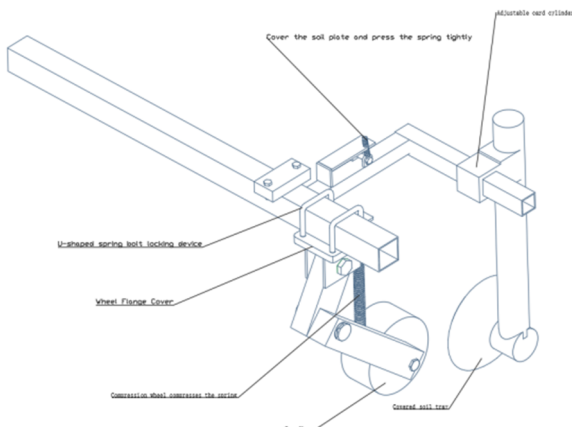

Figure 3. Suppressing the Soil Cover Mechanism

Our organization uses compaction wheels to compress the

covered membrane. Each compaction wheel is equipped with a compression spring, which is connected to the compaction wheel through washers and locking pins. The compression spring can be adjusted according to the softness of the soil to ensure that the compaction force is the same and will not damage the membrane. Use a soil cover plate to automatically push the surrounding soil onto the membrane to complete the covering process. The amount of soil cover can also be adjusted. By locking the bolts, it can be adjusted left and right on the crossbeam to achieve the desired amount of soil cover, thus completing the film covering process. The compaction wheel and the soil cover plate are connected to the same crossbeam, and the entire mechanism has a compression spring that can adjust the height of the entire compaction and soil cover device to be consistent. The entire mechanism is fixed to the crossbeam by two pairs of U-shaped bolts and can also be adjusted left and right according to user needs.

3.4. Coating Mechanism Design

This laminating mechanism is designed with double laminating and a staggered spatial structure on both sides. The height of the laminating drum can be adjusted by the boom card cylinder and the laminating drum, achieving a staggered position of the laminating drum, fully utilizing the position of the laminating device, achieving more complete and leak free laminating, and easy film replacement.

4. Field Experiments and Results

4.1. Test Condition

(1) Test site conditions

The experimental site is located in a vegetable planting base, and the plot is generally flat. Pre rotary tillage and land preparation have been completed before the operation. The depth of the plow layer should be controlled between 8-12 cm, and the soil texture should be sticky loam with an average moisture content of 18.2% (which is within the suitable moisture content range of 15% to 20% for mulching operations). According to agricultural requirements, the maximum number of soil blocks with a maximum external size of $\geq 40mm$ per square meter is $\leq 5\%$, and the total experimental area is $6.8hm^2$, which meets the requirements of batch operation testing.

(2) Experimental equipment

Power equipment: The calibrated power of the Dongfanghong-MY1204-9 (G4) tractor is 88.9kW (rated power of 90kW, meeting the matching power requirement of $\geq 75kW$ for the machine);

Core equipment: self-designed soil turning and film covering machine (with a film width of 200cm, 7 rows of operation, and a total weight of 550kg);

Auxiliary equipment: Degradable geotextile film (customized according to the requirements of vegetable planting agriculture, with basic nutrients), electric heating constant temperature air drying oven (used for soil moisture content determination), tape measure (accuracy 1cm), electronic scale (accuracy 0.1g), laser rangefinder (used for measuring centerline deviation in film laying).

(3) Unit status

Before the experiment, complete the assembly and debugging of the unit according to the equipment manual: the tractor and the soil turning and mulching machine are connected by a rear three-point suspension, and the universal transmission shaft is installed in place without any jamming

in the transmission; The double layered rotary tiller shaft speed of the soil turning mechanism is adjusted to 280r/min, and the height of the film covering mechanism is adjusted to 15cm above the ground surface (suitable for vegetable planting and soil covering requirements). The spring pre tension force of the soil covering mechanism is evenly compressed to ensure consistent compaction pressure.

4.2. Test Methods

Experimental basis standard: Referring to the performance evaluation indicators and design requirements of the "Quality of Film Laying Machine Operation (NY/T986-2006)", combined with the "integrated operation" characteristics of the soil turning and film covering machine, determine the testing index system.

Measurement indicators and methods:

Soil turning quality: Measure the depth of rotary tillage at 30 points (qualified for 10-20cm), screen the broken soil rate of 1m² tillage layer (proportion of particle size ≤10mm);

Film quality: Measure the flatness, damage rate, longitudinal tensile rate, and centerline deviation of the 30m daylighting surface;

Quality of covering soil: Measure the width (8-12cm qualified), thickness (2-3cm qualified), and degree of soil leakage at the edge of the membrane;

Homework efficiency: Measure 3 sets of 0.2hm² homework time and calculate the average productivity.

4.3. Experimental Repetition and Data Processing

Each experiment was independently repeated 3 times, and after excluding outliers (data with deviations exceeding 10% of the mean), the arithmetic mean was taken as the final experimental result to ensure data reliability.

Table 2. Field test results of soil turning and film covering machine

test metrics	unit	Test results
Qualification rate of rotary tillage depth	%	86
Soil fragmentation rate	%	92
Flatness of daylighting surface	%	95
Mechanical damage degree of daylighting surface	%	28
Longitudinal stretch rate of plastic film	%	6
Qualified rate of membrane edge covering width	%	93
Qualified rate of membrane edge covering soil thickness	%	91
The degree of soil leakage in the plastic film	%	0.5
Deviation of the centerline of the film laying	mm	15
productivity	hm ² /h	0.42

Test results

The test results are shown in Table 2, and all operational indicators of the soil turning and film covering machine meet the design expectations and relevant national standard requirements.

Result Analysis

(1) Analysis of soil turning quality

The qualified rate of rotary tillage depth reached 86%, and the soil fragmentation rate was 92%, indicating that the double-layer rotary tillage blade shaft (front axis forward rotation, rear axis reverse rotation) design of the soil turning mechanism is effective: the forward rotation blade shaft achieves deep soil loosening, and the reverse rotation blade shaft further crushes soil blocks, meeting the agronomic requirements of vegetable planting for "loose and fine tillage layers", while avoiding the problem of uneven soil blocks caused by traditional single blade rotary tillage.

(2) Analysis of Film Coating Quality

The flatness of the daylighting surface is 95%, the degree of mechanical damage is 28%, and the longitudinal stretching rate is 6%, indicating that the "double film left and right staggered" design of the film covering mechanism is reasonable. The height adjustment function of the boom card cylinder and the film covering roller ensures that there are no obvious wrinkles when laying the film; The staggered layout of the laminating drum reduces the friction between the film body and the frame, and lowers the risk of mechanical damage; A lower longitudinal stretching rate (≤ 7%) ensures the integrity of the film and avoids nutrient loss caused by stretching.

(3) Analysis of soil cover quality

The qualified rates of the width/thickness of the membrane edge covering soil are 93% and 91% respectively, and the degree of soil leakage is only 0.5%, reflecting the reliability of the compaction covering mechanism: the left and right adjustment function of the covering plate can accurately control the amount of soil covering, and the U-shaped spring bolt locking device cooperates with the compression spring to ensure consistent compaction pressure under different soil softness, which not only avoids the problem of "the membrane body being damaged by excessive covering soil" or "the membrane body being lifted by wind due to insufficient covering soil", but also achieves no leakage covering soil operation.

(4) Analysis of homework efficiency

The productivity reaches 0.42hm²/h, which is within the design range (0.3~0.5hm²/h), and the integrated operation mode (one-time completion of soil turning, film covering, and soil covering) improves the operation efficiency by about 40% compared to the traditional "rotary tiller+manual film covering" mode. At the same time, it reduces the number of unit entry times, lowers the risk of soil compaction, and meets the requirements of "light, simplified, and efficient" vegetable planting.

References

- [1] Liang Haozhi The effects of fulvic acid and Cu (II) on the blockage of suspended solids in aqueous media [D]. Guilin University of Technology, 2023.
- [2] Chi Ming Road Design and Experimental Study of Film covered Fertilization Transplanter [D]. Inner Mongolia Agricultural University, 2013.
- [3] Mou Ying Comparison and Improvement Strategies of Water saving Irrigation Technologies [J]. Agricultural Technology and Equipment, 2025, (09): 38-40.

- [4] Zhao Zhen Research on Mechanized Technology and Machinery for Dryland Water saving Film Laying [J]. Agricultural Science and Equipment, 2017, (10): 54-55.
- [5] Mi Jing Design and Experimental Study of Variable Fertilization Machine for Orchard Ditching [D]. Chongqing Three Gorges University, 2025.
- [6] Guan Chunsong, Cui Zhichao, Gao Qingsheng, etc Design of Dual axis Rotary Tillage Soil Crushing Test Platform and Layered Tillage Test [J]. Journal of Agricultural Engineering, 2021, 37 (10): 28-37.0-004.