



# Integrating AI and statistical methods for enhancing civil structures: current trends, practical issues and future direction

Asraar Anjum, Meftah Hrairi\*

*Department of Mechanical and Aerospace Engineering, Faculty of Engineering, International Islamic University Malaysia, P.O. Box 10, 50728, Kuala Lumpur, Malaysia*  
asraar.anjum@live.iium.edu.my and meftah@iium.edu.my

Abdul Aabid

*Department of Engineering Management, College of Engineering, Prince Sultan University, PO BOX 66833, Riyadh 11586, Saudi Arabia*  
aaabid@psu.edu.sa, <http://orcid.org/0000-0002-4355-9803>

Norfazrina Yatim

*Department of Mechanical and Aerospace Engineering, Faculty of Engineering, International Islamic University Malaysia, P.O. Box 10, 50728, Kuala Lumpur, Malaysia*  
noorfazrina@iium.edu.my

Maisarah Ali

*Department of Civil Engineering, Faculty of Engineering, International Islamic University Malaysia, P.O. Box 10, 50728, Kuala Lumpur, Malaysia*  
maisarahali@iium.edu.my

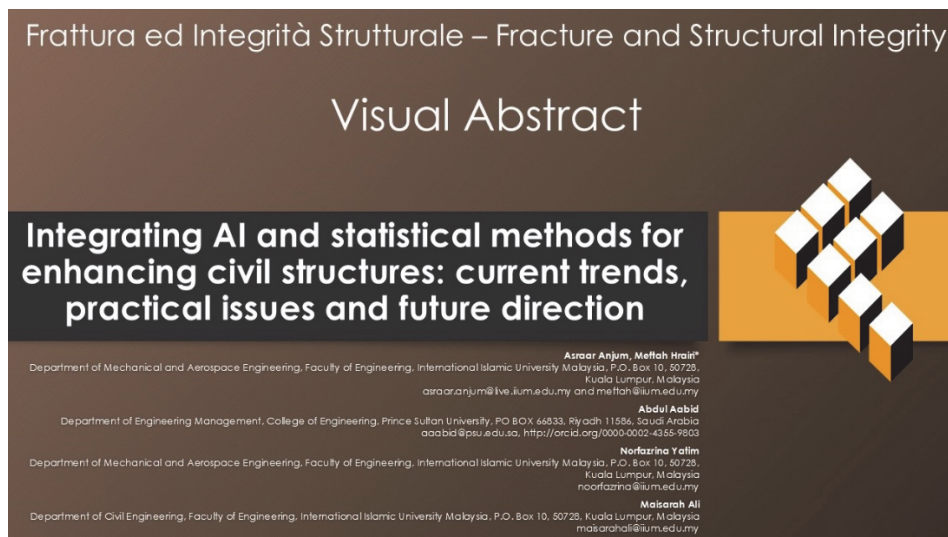

**Citation:** Anjum, A., Hrairi, M., Aabid, A., Yatim, N., Ali, M., Integrating AI and statistical methods for enhancing civil structures: current trends, practical issues, and future direction, *Fracture and Structural Integrity*, 71 (2025) 164-181.

**Received:** 06.08.2024

**Accepted:** 25.10.2024

**Published:** 27.10.2024

**Issue:** 01.2025

**Copyright:** © 2024 This is an open access article under the terms of the CC-BY 4.0, which permits unrestricted use, distribution, and reproduction in any medium, provided the original author and source are credited.

**KEYWORDS.** Optimization Techniques, Artificial Intelligence (AI), Civil Structures, Fuzzy Logic, Design of Experiments (DOE).



## INTRODUCTION

The field of civil engineering is currently experiencing a significant transformation with the integration of advanced computational techniques, particularly artificial intelligence (AI) and statistical optimization methods. The need for civil structure that is not only resilient and cost-effective but also environmentally sustainable has become more pressing as global challenges such as urbanization, climate change, and resource scarcity intensify. To meet these demands, researchers are increasingly turning to AI-driven methods like Fuzzy Logic (FL), Design of Experiments (DOE), and Artificial Neural Networks (ANNs). These sophisticated techniques are at the forefront of innovation, offering new ways to enhance the design, construction, and maintenance of civil structures. They address the growing complexity of engineering projects by improving structural reliability, predicting potential failures, and optimizing resource usage—all of which contribute to safer and more efficient civil structure development.

Recent studies underscore the effectiveness of these AI-driven techniques. For example, the application of ANNs in predicting the compressive strength of concrete has been shown to significantly improve prediction accuracy, achieving an  $R^2$  value of 0.96, compared to traditional methods [1]. Additionally, the use of DOE in seismic design optimization has reduced the time required for experimentation and has led to more reliable earthquake-resistant structures [2]. Such advancements highlight the transformative role AI is playing in civil engineering, not only in terms of optimizing processes but also in addressing the multifaceted challenges faced by engineers in the modern world.

Despite these advances, the adoption of AI and optimization methods in civil engineering is not without challenges. One of the primary obstacles is the handling of large amounts of data and the complexity of decision-making processes in civil engineering research. These research projects involve numerous variables, and the decision-making often takes place in environments characterized by uncertainty. Techniques like fuzzy logic, which allows for more intuitive and flexible problem-solving by modelling uncertainties, have become essential in this regard [3]. However, issues such as data privacy, computational demands, and the need to integrate AI with existing engineering workflows remain significant hurdles. Moreover, as civil engineering constructions increasingly involve interdisciplinary collaboration, there is a need for AI tools that can seamlessly fit into traditional processes while offering the flexibility to handle complex, real-world problems.

In civil engineering, optimization techniques are critical for solving problems related to structural design, material properties, and construction methodologies. Traditional (or "hard") computing methods often fall short in handling the complexity and variability inherent in these problems. In contrast, soft computing techniques, such as AI-based methods and evolutionary algorithms, provide cost-effective solutions by incorporating flexibility and error tolerance into the decision-making process. For example, DOE offers a structured approach for experimenting with complex systems, allowing engineers to optimize processes more efficiently. This method significantly reduces the time and resources needed to identify the most effective design and construction strategies. Fuzzy logic, on the other hand, introduces a means of modelling uncertainty and variability, offering more adaptable decision-making tools in situations where precise data may not always be available.

The integration of these optimization techniques into civil engineering practices cannot be overstated. By enabling engineers to explore a broader range of design and construction developments, these methods not only improve safety and reliability but also advance innovation. Through techniques such as non-destructive testing and real-time monitoring, AI and optimization methods allow engineers to predict and mitigate potential structural issues before they become critical, thereby improving the durability and lifespan of civil structures. The ability to simulate different circumstances also enhances the executive process, enabling engineers to make more informed choices throughout the lifecycle of a construction. This contributes to the creation of stronger, more cost-effective, and environmentally friendly civil structures, aligning with the increasing demands for sustainability in the industry.

Moreover, optimization techniques like AI and DOE play a key role in pushing the boundaries of what is achievable in civil engineering. These methods offer the potential to address some of the sector's most pressing challenges, such as enhancing the performance of structures in earthquake-prone areas or optimizing material used to reduce environmental impact. The motivation behind the application of these techniques is driven by the high stakes in civil engineering monitoring and construction, where civil structure safety, durability, and environmental sustainability are paramount. By synthesizing the most recent advancements in optimization methods, researchers are providing a roadmap for future innovations in the field. As this review seeks to explore, the ongoing integration of AI and optimization techniques into civil engineering will likely continue to expand, addressing gaps between theoretical advancements and practical applications. Specifically, it will highlight the most effective ways in which these techniques can be applied to optimize design, analysis, and managerial processes. Researchers are increasingly focused on cost-effective methods that not only reduce human effort but also save time, as demonstrated by the growing use of DOE, fuzzy logic, and other statistical approaches in current investigations

(Fig. 1). The evolution of these methods will undoubtedly play a critical role in shaping the future of civil engineering constructions and health monitoring, fostering more sustainable, resilient, and efficient civil structure.

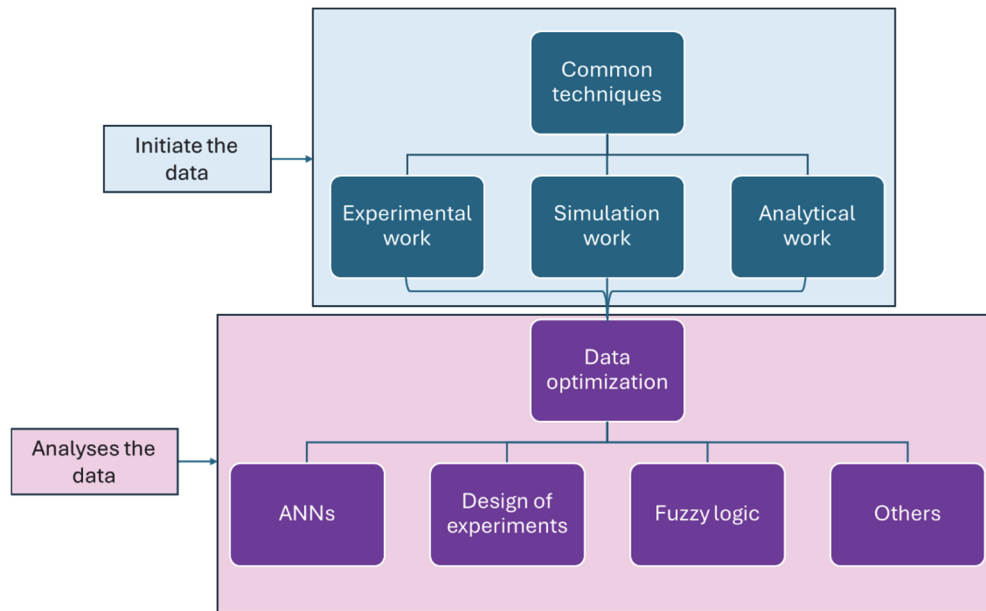

Figure 1: Current Technologies.

## CIVIL STRUCTURES

Civil structures can be in any shape and size based on the requirements, made from distinct materials, and designed with a focus on quality and safety. These structures can maintain their strength when new, but over time, they may lose strength due to external loads and other factors. Recognizing and maintaining the quality and durability of these structures is a critical concern, and researchers often use optimization methods to address these challenges. Structures can be classified as either healthy or unhealthy, with important questions revolving around their health condition and the point at which they may fail completely. This is a common concern, especially in civil engineering.

In reviewing recent literature, several common types of civil structures emerge, each serving distinct applications and facing unique challenges. Concrete structures, including reinforced concrete structures, laterite concrete structures, concrete components, marine concrete structures, CFRP-strengthened concrete structures, and concrete cylinders, represent the largest category. These structures are predominantly studied for their crack characterization, condition assessment, and optimization of materials to enhance their mechanical properties and durability. For instance, Das et al. [4] analyzing cracks in reinforced concrete structures through experimental and computational data-driven techniques, while Zhang et al. [5] focused on evaluating conditions using the impact-echo method and extreme learning machines.

Steel structures, though less frequently mentioned, are critical in civil engineering. Szeptyński and Mikulski [6] explored the optimization for steel beams in compliance with Eurocode 3, demonstrating the importance of design standards in ensuring structural integrity and safety.

Geostuctures, such as those studied by Li et al. [7], involve the use of topology optimization methods for designing soil and rock structures. This category is crucial for maintaining the integrity and effectiveness of foundational systems in civil engineering projects.

Bridges, a fundamental civil structure component, are another key type of civil structure. Research by various authors highlights the use of advanced predictive models to assess and maintain bridge conditions, ensuring their safety and longevity.

Large-scale civil engineering structures, including general civil engineering and specific projects like gas field construction and cement transport, are critical for civil structure development. Studies in this category focus on optimizing project schedules, managing logistics, and implementing advanced frameworks like digital twins for immediate observation and informed choices, as demonstrated by García-Macías and Ubertini [8].

Soil structures, which include various types of soil compositions, are essential for calculating shear wave velocity and ensuring proper foundation engineering. Research by Molaabasi et al. [9] emphasizes robust optimization methods to handle uncertainties in soil properties, thereby improving the accuracy and reliability of engineering designs.



This overview of common civil structures underscores the diversity and complexity of the field, highlighting the continuous advancements in materials, design methodologies, and optimization techniques to enhance the performance and durability of these vital civil structures (Fig. 2).

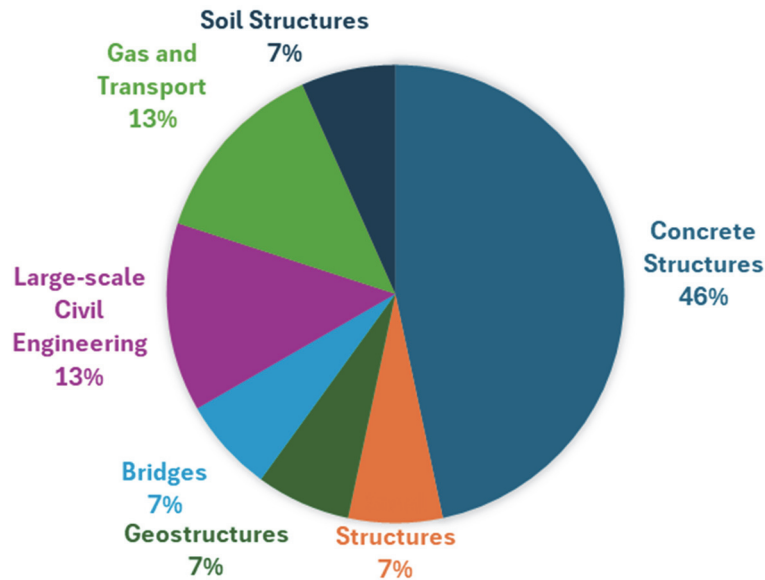

Figure 2: Classification and practical applications of civil engineering structures.

Tab. 1 illustrates the civil structures conditions and composite of materials for a particular application and analysis which were done using optimization techniques.

| Structure                             | Reference | Application   | Damaged/Healthy Condition | Material Used      | Other Important Facts   |
|---------------------------------------|-----------|---|---------------------------|--------------------|---|
| Concrete components                   | [1]       | Predicting compressive strength (CS)                      | Healthy                   | Concrete           | Hybrid GBRT with GridSearchCV; high prediction accuracy with $R^2 = 0.9612$                         |
| Bridges                               | [10]      | Predicting bridge deck conditions                         | Healthy                   | Composite concrete | Uses Random Forest (RF) and eXtreme Gradient Boosting (XGBoost); helps allocate budgets efficiently |
| Marine concrete structures            | [11]      | Diagnosing causes of distress and repairs                 | Damaged                   | Composites         | Uses decision support system for repair management  |
| CFRP-strengthened concrete structures | [12]      | Monitoring failure modes                                  | Damaged                   | CFRP               | Uses acoustic emission for monitoring   |
| Concrete cylinders                    | [13]      | Estimating ultimate axial strain of FRP-confined concrete | Healthy                   | FRP                | Uses explicit and implicit algorithms   |
| Cantilever beam and railway bridge    | [14]      | Assessing dynamic decision-making capabilities            | Healthy                   | Metal type         | Uses digital twin framework; tests with high-fidelity simulation data with Gaussian noise           |

Table 1: Structures information and its conditions.

## OPTIMIZATION METHODS

In civil engineering, optimization methods enhance the design and functionality of structures by systematically refining parameters to achieve goals such as strength, safety, and cost-effectiveness. Techniques such as genetic algorithms, simulated annealing, and particle swarm optimization evaluate different design alternatives to identify the best possible solutions. These techniques enhance structural reliability and resource management while ensuring compliance with engineering standards and regulations.

In this section, a review has been made on a few common optimization techniques that were utilized in recent years to predict or statistically analyse the civil structural application whether the structure is in healthy or unhealthy conditions for different types of structures.

### *Artificial neural networks*

Artificial neural networks (ANNs) utilized into any engineering method for analysing data. Wherever huge data and complex problems have occurred then ANNs have made a major contribution in solving such problems.

ANNs are computational models (Fig. 3) inspired by the human brain's neural architecture, capable of recognizing patterns and learning from data. In civil engineering, ANNs are increasingly utilized for various applications, enhancing the efficiency and accuracy of structural analysis and design. They are particularly useful in predicting the behavior of complex systems under different loading conditions, optimizing material usage, and monitoring structural health. ANNs can analyse vast amounts of data from sensors embedded in structures, identifying potential issues such as cracks or deformations before they become critical. This predictive maintenance approach not only improves safety but also reduces repair costs. Additionally, ANNs assist in the design of innovative materials and construction methods by simulating and evaluating numerous scenarios, leading to more resilient and sustainable structures. Overall, the integration of ANNs in civil engineering significantly advances the field, ensuring safer, more efficient, and cost-effective civil structure development.

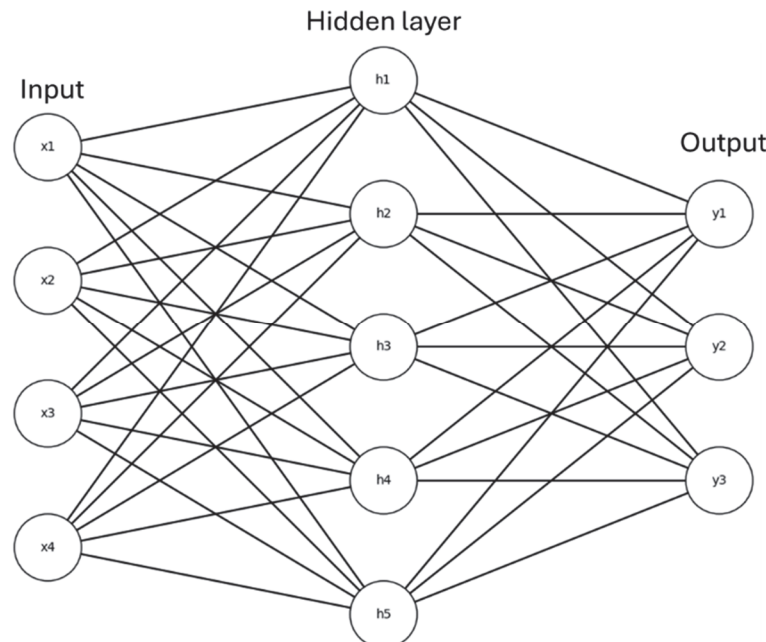

Figure 3: Sample of ANNs computational model.

Recently a critical review has been conducted on the ML approach which is the major topic of ANNs [15]. In their review work, they have extracted the advanced data science approach in solving the civil engineering problem particularly damage detection in the civil structures and some other purposes. Based on their review work, it has been found that optimization techniques have a major contributing factor in solving the engineering problem. Therefore, this section collects the work done in civil structures considering the ANNs approach. This information will help conduct quality research in solving complex problems with cutting-edge technology. An overview of ANN application for civil engineering studies has been illustrated in Fig. 4.

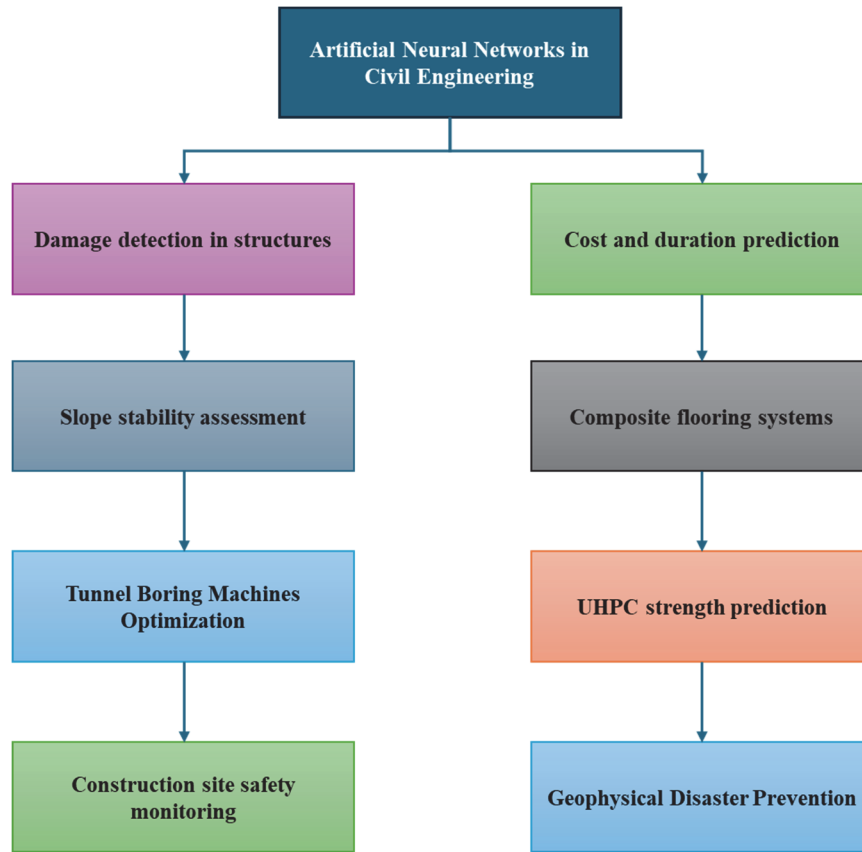

Figure 4: Application of ANN in civil engineering.

Research spans various fields, including environmental construction, genetic science, seismic engineering, and geohazard mitigation, alongside the investigation of relevant processes and materials. These areas contend with substantial amounts of Big Data and complex iterative algorithms. To address computational complexity, approaches involve decreasing computing iterations using Artificial Intelligence or Conditional Algorithms or reducing the duration of each iteration through Data Filtration and Quantization. Enhancing computing capabilities can be achieved through technological shifts like transitioning to silicon (Si) or gallium arsenide (GaAs) and by altering paradigms such as Control Flow or Data Flow [16]. The study explored how ANNs could analyze building details to predict construction project costs and durations. Using MATLAB, a forward-feeding neural network utilizing the Levenberg–Marquardt training method and mean squared error (MSE) as the performance metric was employed to attain an optimized network architecture [17]. Additionally, the dependability ANNs were used to forecast the embedment depth as the FORM was used to investigate cantilever sheet pile walls embedded in cohesive soil. Artificial bee colonies, ant colonies, and teaching-learning-based optimization are examples of optimization strategies that were employed to enhance accuracy [18].

A novel approach for forecasting the strength and performing multi-objective optimization (MOO) of ultra-high-performance concrete (UHPC) was developed, promoting sustainable construction practices. Various ML models based on tree and boosting ensembles were combined to create a reliable prediction tool for UHPC's uniaxial CS, incorporated into a super learner model for MOO [19]. Enhanced Rao algorithms (ERao), incorporating an enhanced statistically regenerated method, were applied to structural design optimization problems, demonstrating effective solutions for addressing constraints in structural design [20]. For seismic slope stability analysis, a sequential hybrid optimization method integrating the tunicate swarm algorithm (TSA) and pattern search (PS) was proposed to tackle the minimum FOS related to critical failure surfaces [21]. The Cascade optimization technique, incorporating a genetic algorithm, was developed to attain the optimal design of RC frame structures significantly reducing time and optimizing large-scale concrete structures [22]. Tab. 2 illustrates the ANNs approach limitation and challenges in civil engineering structures.



| Application                           | Authors' Aim  | Limitation/Challenge  | References |
|---------------------------------------|---|---|------------|
| Predicting construction project costs | Analyses building details to predict project costs and durations using ANNs   | Requires extensive historical data and precise network architecture tuning for accurate predictions                         | [17]       |
| And sheet piles embedment depth       | Examine the dependability of overhanging sheet pile barriers and predict embedment depth using ANNs                   | Dependence on accurate soil property data and high computational resources for complex optimization techniques              | [18]       |
| UHPC strength prediction              | Create a reliable prediction tool for UHPC's uniaxial CS and conduct MOO  | Requires comprehensive data on material properties; ensemble models can be resource-intensive to train and validate         | [19]       |
| Structural design optimization        | Address structural design problems using enhanced Rao algorithms  | Enhanced Rao algorithms need high computational power for large-scale problems and accurate boundary handling               | [20]       |
| Seismic slope stability analysis      | Introduce a hybrid optimization algorithm for analysing seismic slope stability                                       | Combining global and local search algorithms increases computational complexity and resource requirements                   | [21]       |
| RC frame structure optimization       | Achieve optimal configuration of RC frame systems utilizing the Cascade optimization technique and genetic algorithms | Integration of multiple optimization methods can be complex and time-consuming, requiring robust interfacing tools          | [22]       |
| TBM control parameter optimization    | Enhance control parameters of TBMs using an advanced Loss Function-based ANN integrated with QPSO                     | High complexity in designing effective loss functions and integrating with quantum algorithms; computationally intensive    | [23]       |
| Construction project TCQS analysis    | Optimize time, expense, quality, and safety compromises in building projects employing AOSMA                          | Hybrid algorithms like AOSMA require detailed data and significant computational resources for multi-objective optimization | [24]       |
| Safety monitoring with deep learning  | Develop a practical prototype for safety monitoring in construction using deep learning algorithms                    | Practical implementation is limited by the accuracy of computer vision algorithms and the need for real-time processing     | [25]       |
| Large-scale mathematical optimization | Address large-scale optimization challenges using the Hybrid ALO  | Hybrid ALO faces difficulties with larger-scale problems and requires significant computational power                       | [26]       |

Table 2: Limitations, and Challenges in Applying ANNs in Civil Engineering.

### Design of experiments

This review covers a few of the latest investigations using the DOE approach. The DOE has different analysis approaches such as response surface, regression, statistical, linear/non-linear, and Taguchi [27]. To address the challenge of numerous test cases and enhance configuration testing, combinatorial testing with an Orthogonal Array Testing Strategy (OATS) is suggested as a systematic, statistical approach that emphasizes pair-wise interactions. By using models to produce minimal test inputs that address essential input combinations, OATS aims to lower testing expenses, expedite product launches, and minimize field defects through the creation of efficient and comprehensive test cases. It often results in a 50% reduction in tests while detecting more faults. Additionally, the Taguchi method in software testing prioritizes performance characteristics close to target values, improving product quality [28]. In most studies, data optimization for optimum results response surface methodology (RSM) was found when it comes to civil engineering applications it has been employed in most of the investigations. Fig. 3 shows the fundamental process of using the DOE to solve any type of civil structural problem. The DOE involves several techniques to optimize the results based on the problem type such as linear or non-linear problems. Also, it depends upon the selection of an OA and design type like Taguchi design or full-factorial design. Several factors influenced the DOE to optimize the results commonly used the techniques. These techniques offer various ways to efficiently optimize outcomes by systematically exploring factor interactions and identifying optimal parameter settings.

Upon reviewing the existing research wherein researchers utilized DOE to optimize their respective problems, extracted valuable insights that contribute significantly to findings (Fig. 5). The response surface method combined with the NSGA-II algorithm was employed for optimizing seismic design based on resiliency in standard highway reinforced concrete (RC) bridges. The impact of various design factors on the seismic performance of an RC bridge pier wall was compared with simulated seismic tests conducted on full-scale RC columns, using a DOE technique to predict the nonlinear behavior of

the pier wall. Sensitivity analysis was performed using nonlinear FE methods, and the compressive strength and yield strength of the reinforcement bars were assessed through nonlinear FE analysis [2]. The reliability index across different levels of corrosion is determined using the first-order reliability method (FORM) along with the response surface method, producing a fragility curve. This data is used to assess and analyze structural robustness. By comparing the robustness of various structures, it is possible to identify which types are more resistant to corrosion findings can be utilized to plan maintenance and repairs [29].

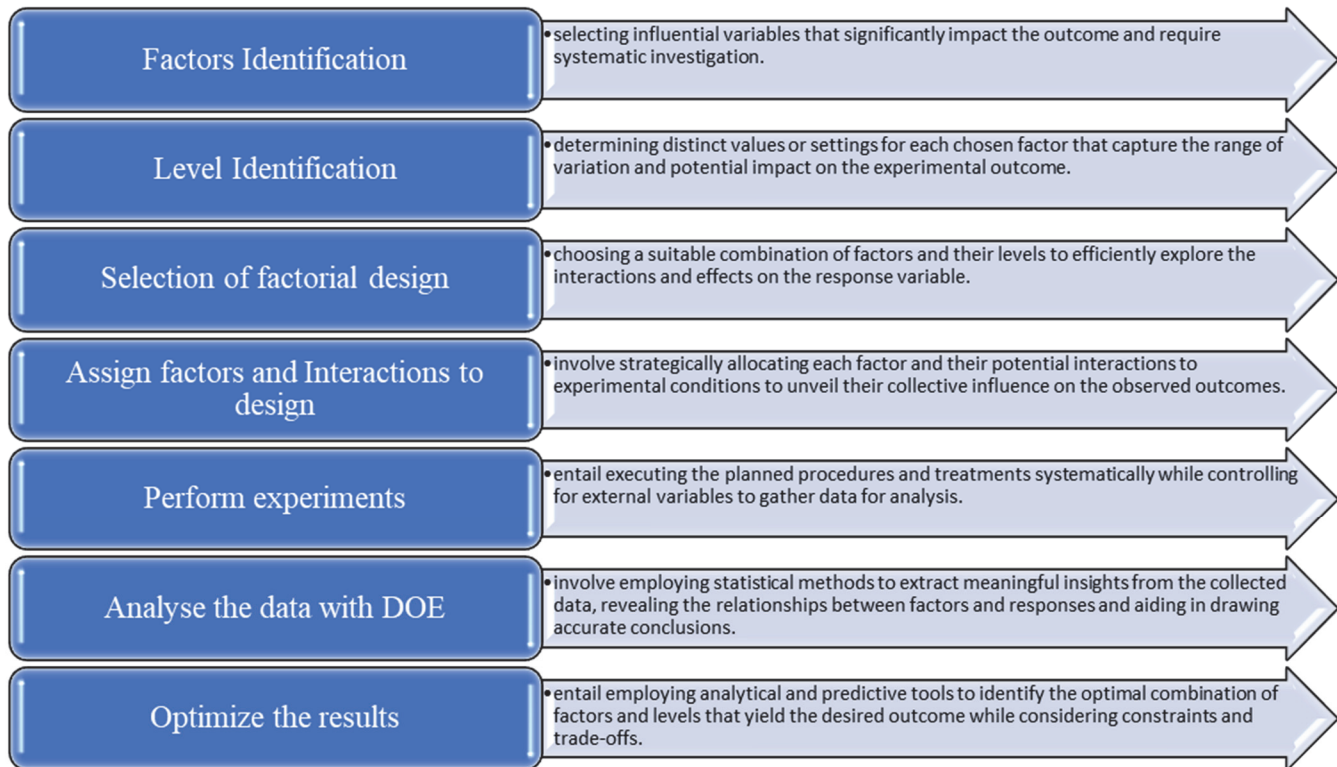

Figure 5: Categorization of Methods for Developing Statistical Models in SHM.

To examine diverse analytic situations, DOE was employed which included the impacts considering the frame aspect ratio and seismic intensity, the method uses multiple-response optimization to find the best design variable values. These values are crucial for minimizing both the maximum transient and residual roof drift ratios simultaneously, along with the minimization of peak floor acceleration. The technique leverages response surface modelling and a desirability approach to achieve these goals concurrently [30]. To produce optimal Eco-friendly concrete mixes using RSM, which includes various amounts of polypropylene fibre used in concrete pavement, as well as to determine the shrinkage factor related to cracking in concrete pavements [31]. A review has been made based on the optimization method considering DOE and other aspects, the authors contributed to finding the research gap and critically analyzed the existing work which was useful for beginner researchers [32].

### *Fuzzy logic*

In knowledge-based systems, such as those employed in civil construction engineering, challenges arise concerning the management and quality of knowledge. The unique aspects of construction engineering impact the nature of knowledge resources, which can be characterized by limitations, uncertainties, ambiguity, varying degrees of reliability, and incompleteness. One significant source of knowledge in this field comes from the mental models of experts working within specialized areas of construction engineering. It may be determined that just a portion of the knowledge [33]. In these investigations, an adaptive neuro-fuzzy inference system (ANFIS) and an ANN model were utilized to examine the relationship between concrete CS and ultrasonic pulse velocity measurements. This examination was performed using experimental data from cores extracted from various RC structures of differing ages and with unspecified concrete mixture ratios [34].

Reinforced bridges may also be managed using fuzzy logic inference methods. FIS-based models analyze various facts or knowledge combinations by treating them with same time and suggest the final response or guess as the hypothesis of the

highest belief, which is extremely near to the actual scenario. The sole requirement for bridge inspection is a good inspector's judgment, as no degraded area calculation is required. It should be emphasized that fuzzy systems may anticipate outputs with some noise [35]. A novel approach has been introduced to evaluate the severity of cracks in support columns by using fuzzy cognitive maps (FCM) to encapsulate the expertise of specialist's insights gathered from relevant literature for grading the severity of fractures in RC columns [36]. Additionally, a hybrid neuro-fuzzy and self-tuning predictive model, as shown in Fig. 6, has been implemented to predict concrete carbonation depth using the ANFIS approach [37].

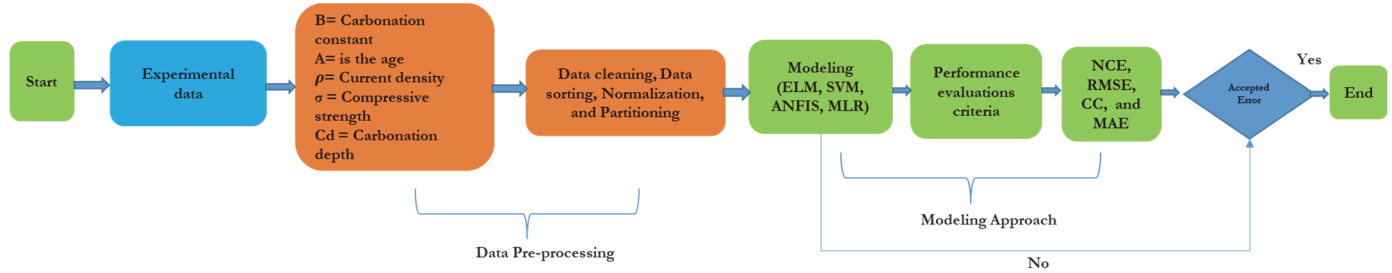

Figure 6: Overall flowchart developed for the performance evaluation [37]. Reprinted under the Creative Commons (CC) License (CC BY-NC-ND 4.0).

On a different note, a model was developed using acceleration records ranging from 0.1 g to 1.5 g, involving a concrete frame with shear walls consisting of four stories and four bays, to determine the damage rate. A total of 450 data points were generated for testing, encompassing six input variables and one output variable. Three distinct data-centric models, like ANN, ANFIS, and MLR, were employed (Fig. 7) to forecast the displacements in this dataset [38].

*Others*

To address the limitations of current procedures, Chan et al. [39] have introduced a conceptual framework, as illustrated in Fig. 8, which integrates building information modelling (BIM) with modern computer and imaging technologies. This integration improves the reliability and efficiency of existing practices for managing bridge assets. It validates and suggests incorporating BIM findings from advanced imaging and data processing into future bridge assessments. In a study related to civil structures, a diagnostic support system for identifying causes of deterioration and repair strategies in marine concrete structures has been presented [11]. Additionally, a version of generative adversarial networks (GAN), referred to as cycle-consistent Wasserstein deep convolutional GAN with gradient penalty, was created to investigate the changes in structural dynamic signatures when transitioning from a damaged to an undamaged state. This research also examines the potential for predictive damage detection using this approach. The findings indicate that the suggested model is capable of accurately simulating damaged responses from undamaged ones and vice versa. This methodology enables an understanding of the impaired condition while the structure remains in an undamaged state, and vice versa [40]. Furthermore, acoustic emissions have been studied for monitoring failure modes in CFRP-strengthened concrete structures [12].

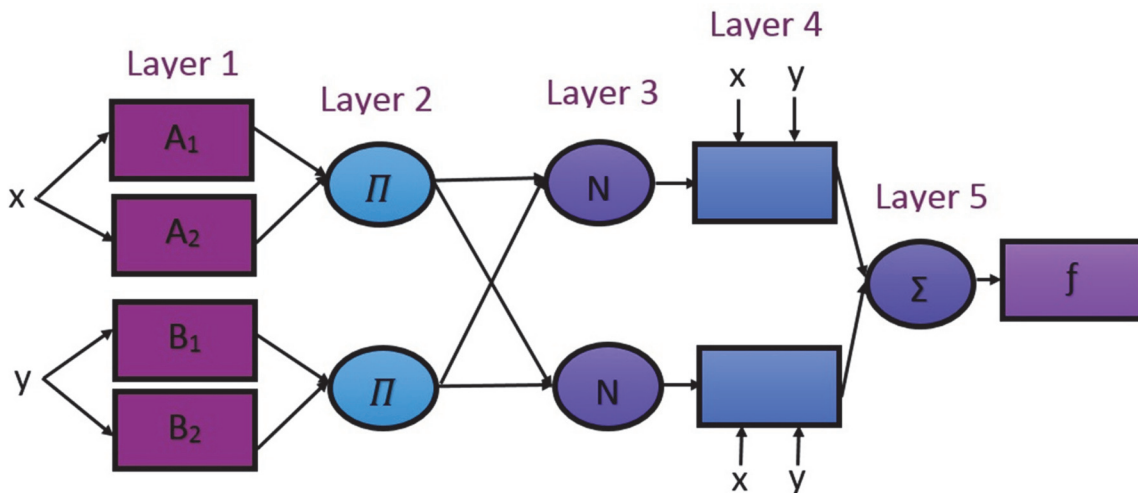

Figure 7: Structure of ANFIS with two input variables, one output variable, and five layers [38]. Reprinted under the Creative Commons (CC) License (CC BY 4.0).

Predictive models for concrete properties were created using radial basis function and polynomial kernels based on mixed component content [41]. Recent research has introduced data-driven techniques to enhance the corrosion assessment of RC structures [13], as well as estimating the final axial deformation of concrete cylinders reinforced with FRP, utilizing both direct and indirect computational methods [42].

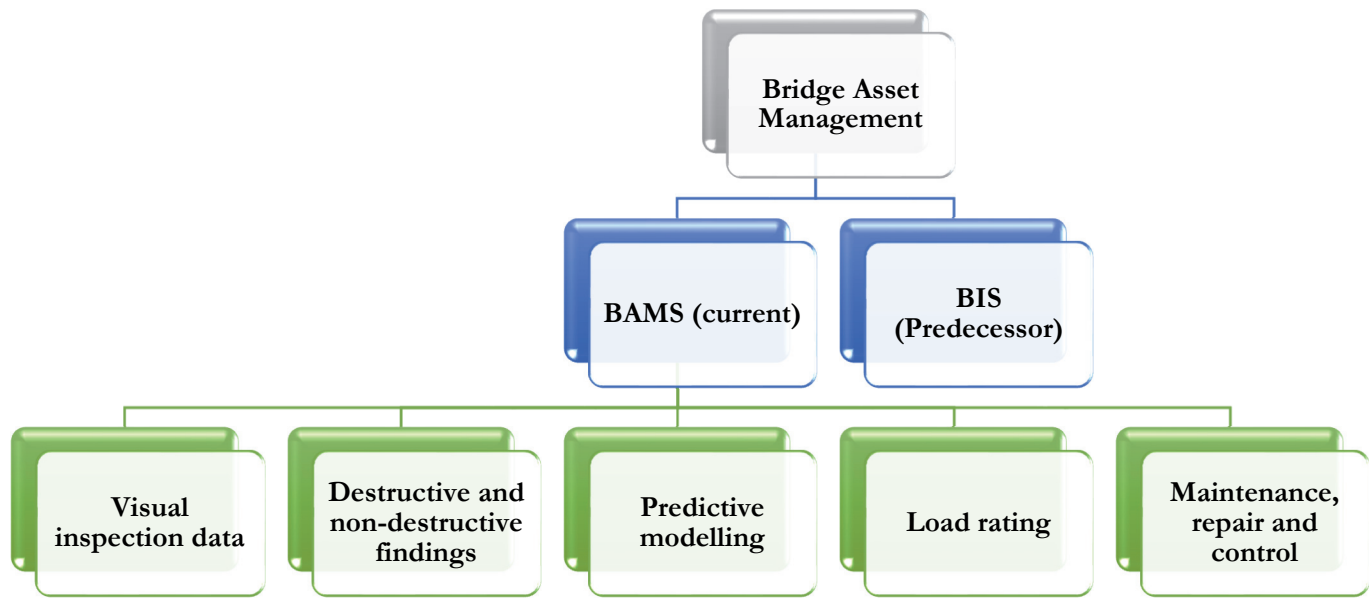

Figure 8: Typical information flow for bridge asset.

A novel damage classification method, focused on vibration data from RC beams, has been developed to efficiently handle real-time big data in the frequency domain. Such a reliable on-site damage diagnostic system necessitates a statistical pattern recognition approach, obviating the need for computationally intensive discrete modeling techniques and reverse analysis approaches, along with their related adjustments and intrinsic inaccuracies. In this regard, Al-Ghalib et al. [43] introduced a dual-phase method integrating key feature analysis and Karhunen–Loeve transformation which is based on statistical methods for damage categorization. Additionally, Gui et al. [44] introduced 3 optimization-driven support vector machines for identifying damage. These models optimize parameters such as constraint coefficients and Gaussian kernel function settings using methods such as grid search, particle swarm optimization, and evolutionary algorithms. Two different feature extraction approaches, particularly focusing on sequential data were used to identify significant damage features.

The study examined the flexural fracture behavior of RC beams using a combination of experimental and numerical methods. Experimental research investigated the influence of adjusting the ratio of reinforcing steel in beam cross-sections on flexural fracture. This led to the development and validation of a digital imaging-based software for immediate crack visualization and measurement using spatiotemporal video surveillance data from beam testing. This tool, based on experimental insights, provides a valuable resource for structural designers and practitioners aiming to design RC members and systems with improved serviceability [4].

## CRITICAL ANALYSIS AND DISCUSSION

**T**hrough a meticulous analysis of these methodologies, the work illuminates the potential for innovative optimization in structural engineering, maintenance, and design processes. However, a critical examination of the review reveals certain areas where practical issues and challenges are encountered, as well as opportunities for further research and development.

It examines optimization methods in civil engineering, emphasizing their potential to optimize structural design, material properties, and construction techniques. It highlights the significance of methods such as DOE, fuzzy logic, and non-destructive testing, though it also identifies several critical areas that need more in-depth. Tab. 3 listed recent studies on such cases by giving the overview studies.



Another significant concern is the integration of advanced optimization techniques into established engineering workflows. The regulatory compliance challenges highlighted in research including work by M. Khajehzadeh et al. [21] and P. Salimi et al. [22] underline the need for these techniques to evolve in tandem with regulatory standards, ensuring they are not only innovative but also compliant. Additionally, the works of L. Ngoc Quynh Khoi [26] and H. Elhegazy et al. [45] illustrate that while these methods show promise in pilot studies, scaling them to larger projects involves overcoming resistance within engineering firms accustomed to traditional methods.

As emphasized by the reliability-based approaches by E. S. Cavaco et al. [29] and optimization techniques discussed by S. Moradi and H. V. Burton [30] reveal limitations in accurately predicting structural responses under dynamic conditions. Similarly, S. Hooshmandi et al. [2] and S. Hu et al. [46], model predictions often fall short due to simplifications in methodologies like the response surface and sensitivity analysis, which may not fully account for complex interactions in real-world scenarios. Furthermore, the discussion on interdisciplinary integration and computational resource demands is critical but insufficiently addressed. Effective application of these methods necessitates robust interdisciplinary collaboration and substantial computational resources.

| Structure                          | Technique  | Focus   | Limitation  | Outcome   | References |
|------------------------------------|--|---|---|---|------------|
| Concrete components                | Hybrid GBRT with GridSearchCV                              | Predict CS with increased precision   | Limited to tested input data ranges   | Higher prediction accuracy with $R^2 = 0.9612$ and $RMSE = 2.3214$  | [1]        |
| Bridges                            | Random forest (RF) and eXtreme gradient boosting (XGboost) | Predict bridge deck conditions accurately   | Requires separate analysis for each geographic location to select impactful features    | Assists organizations in distributing funds effectively and acquiring precise data for upcoming bridges           | [10]       |
| Cantilever beam and railway bridge | Digital twin framework                                     | Evaluate the real-time decision-making abilities of health-conscious virtual replicas | Tests conducted with accurate simulation results distorted by additional Gaussian noise | Encodes asset-twin system, end-to-end information flow, and evolution over time with quantified uncertainty       | [14]       |
| Construction projects              | AOSMA  | enhance duration, expenses, standards, and security for building projects             | Modification of SMA to AOSMA required for better project completion                     | Effective simultaneous optimization of objectives identifies Pareto-optimal solutions                             | [24]       |
| Slope under earthquake forces      | ANNs and SCA   | Predict FOS for slopes subjected to both static and dynamic forces                    | Takes an extended period to accurately reach an error minimum                           | Effective for static and seismic safety factor estimation with $RMSE = 0.023$ and correlation coefficient = 0.984 | [47]       |
| Gas field construction             | Critical chain project management (CCPM)                   | Determine time buffer sizes in engineering and construction projects                  | Needs integration with resource-leveling algorithms for unpredictable changes           | More stable planning compared to traditional methods  | [48]       |
| Concrete block                     | ML different algorithms                                    | Enhance damage detection in concrete block using different learning techniques        | Limited experiment data was used for training and testing the data                      | Effective with multiple variation of materials and dimensional parameters to enhance SHM                          | [49]       |
| Geostructures                      | Limit analysis-based topology optimization method          | Integrate mixed limit analysis and density-based topology optimization                | Enables a dual-material approach centered on maximum load-bearing strength              | Progresses Geostructures design techniques, fostering eco-friendly and durable civil structure                    | [50]       |

Table 3: Overview and outcome of recent studies of civil structures.



Future research should focus on developing more robust data collection and preprocessing techniques to mitigate the sensitivity of selected optimization methods to input data quality. There is also a need for comprehensive studies that compare soft computing methods with traditional optimization techniques to delineate their specific advantages and limitations. Interdisciplinary collaboration must be enhanced through structured educational programs and knowledge transfer initiatives to bridge the gap between civil engineering and computational sciences. Additionally, addressing computational resource constraints through the development of more efficient algorithms, leveraging cloud computing, and creating simplified yet accurate models will be crucial. To ensure practical applicability, future studies should also explore strategies for integrating these advanced methodologies into existing engineering workflows, supported by change management and demonstration of their value. Lastly, keeping pace with regulatory changes and ensuring data privacy and security will be vital for the broader acceptance and implementation of these optimization techniques in civil engineering. Fig. 9 presents the frequency of various optimization methodologies applied in civil engineering over recent years. It highlights that ANNs are the most employed and followed closely by Design of Experiments (DOE) and Fuzzy Logic. Non-destructive Testing and Response Surface Methodology (RSM) also show significant usage. Techniques like Evolutionary Polynomial Regression (EPR), Hybrid Optimization Techniques, as well as Support Vector Regression (SVR) are moderately utilized. Conversely, techniques like Random Forest (RF) and Extreme Gradient Boosting (XGBoost) are less frequently applied. This distribution underscores the prominence of AI-driven and experimental design approaches in optimizing civil engineering structures.

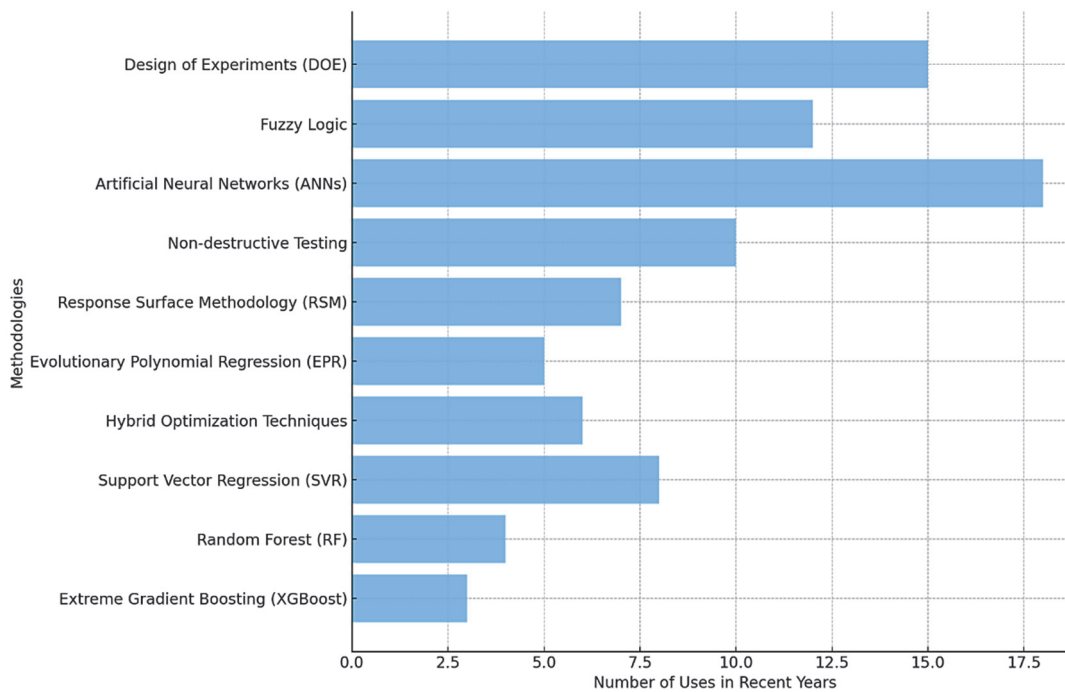

Figure 9: Frequency of different optimization methodologies in civil structures.

Fig. 10 illustrates the distribution of various civil engineering applications that have been addressed using optimization methods. The most frequently targeted application is damage detection, accounting for 15.8% of the total, highlighting its critical importance in maintaining structural integrity. Seismic design optimization follows at 13.2%, emphasizing the need to enhance the earthquake resilience of civil structures. Structural health monitoring constitutes 11.8%, reflecting ongoing efforts to continuously assess and ensure the safety of structures. Construction project management and corrosion assessment each represent 10.5%, indicating significant optimization efforts to improve project efficiency and material durability, respectively. Concrete carbonation prediction and crack characterization both account for 9.2%, underscoring the importance of predicting and mitigating material degradation and structural cracks. Slope stability analysis (7.9%), bridge condition assessment (5.3%), and concrete mixture optimization (6.6%) also feature prominently, demonstrating a broad application of optimization techniques to enhance the performance and safety of civil engineering projects.

### Practical issues

This section involves summarizing valuable perspectives from a variety of sources. Considering the wide array of topics covered in the references—from seismic design optimization, the robustness of corroded structures, and crack



characterization to advanced computational models like CycleGANs and neuro-fuzzy systems, each reference brings its unique set of challenges and limitations. Below is a simplified representation of these limitations based on the thematic analysis of the review and common challenges in the field.

- Optimization methods, such as fuzzy logic, are highly sensitive to the caliber and amount of input information. The subjective nature of rule-setting and membership functions can significantly impact their effectiveness, necessitating robust data collection and preprocessing techniques to enhance model reliability.
- Optimizing civil engineering practices through soft computing techniques requires a deep understanding of both civil engineering principles and computational algorithms. Some of the does not thoroughly discuss the challenges of interdisciplinary collaboration, knowledge transfer, and education needed to bridge these fields.
- Integrating advanced optimization techniques into established engineering workflows can be challenging. Engineering firms often operate within fixed frameworks, making the adoption of new technologies slow and met with resistance. This requires change management and educational efforts to demonstrate the value and feasibility of these new approaches.
- Techniques involving complex simulations or large datasets demand substantial computational resources, which can be limiting for smaller firms with limited budgets. Balancing these demands with available resources through efficient algorithms, cloud computing, or simplified models is crucial.
- The increasing use of data-driven optimization raises concerns about data privacy and security. Projects involving sensitive information or critical civil structure need robust encryption and data protection measures that do not compromise optimization effectiveness.
- Civil engineering projects use a multitude of software tools for different tasks. Optimization techniques that require data from various sources can face challenges related to software interoperability, data formats, and seamless integration of tools across the project lifecycle.
- 

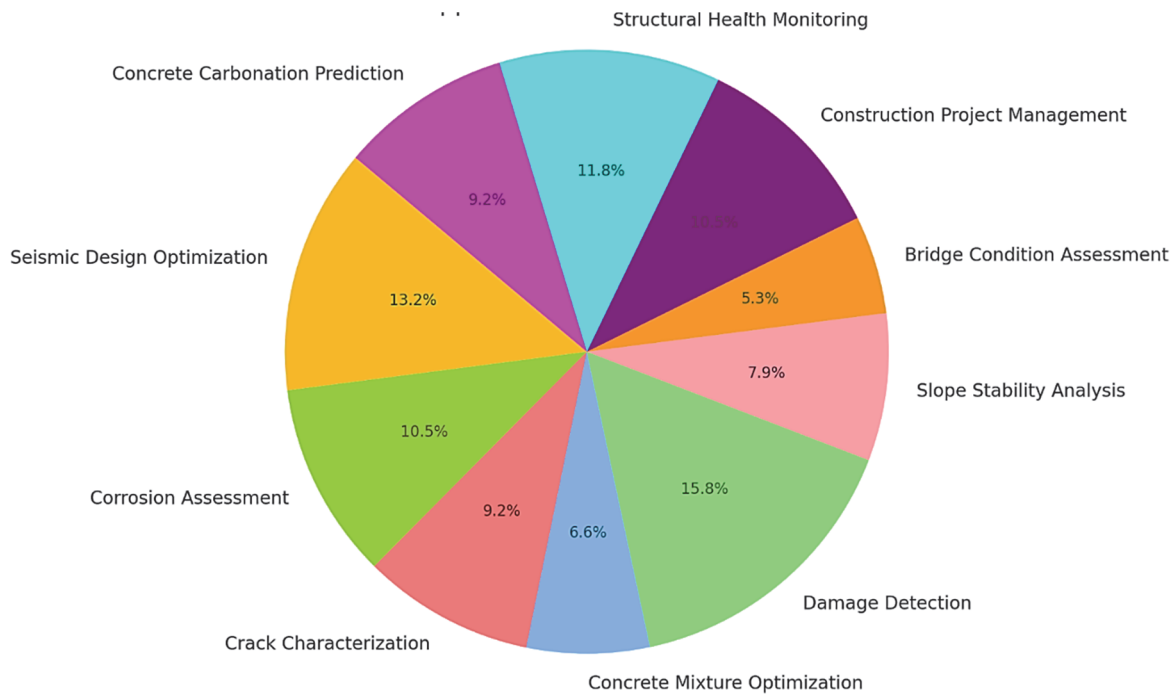

Figure 10. Distribution of civil applications solved with optimization methods.

### Limitations

While the review highlights the significant progress made through AI, DOE, fuzzy logic, and other optimization techniques in civil engineering, several limitations remain that could hinder their broader application. First, these techniques often demand high computational power, which may not be readily available to all engineering works, especially smaller ones. This computational demand presents a barrier to widespread adoption. Furthermore, concerns surrounding data privacy and security are particularly pronounced in AI-driven systems, where large volumes of sensitive information are required to train models and inform decision-making.



The lack of standardized data formats and the diversity of software platforms used across the civil engineering industry also complicate the seamless integration of these techniques. Moreover, while many AI methods excel in controlled environments or simulations, their translation to real-world scenarios can be problematic. For instance, optimization techniques may not always account for the complex interactions between various environmental factors, material properties, and real-time conditions that affect the behavior of structures. Regulatory requirements also evolve constantly, which can slow the implementation of new AI techniques in safety-critical sectors like civil engineering.

Finally, the presence of inherent uncertainties in civil engineering, such as variations in material properties and unpredictable external conditions, limits the accuracy of many AI models. Fuzzy logic helps to mitigate some of this uncertainty, but further refinement is needed to improve the reliability of predictions. These limitations collectively represent significant obstacles that need to be addressed for AI and optimization techniques to reach their full potential in the field. Here is some keys to the limitations:

- AI-driven techniques such as ANNs and optimization methods require substantial computational resources, which are often beyond the reach of smaller engineering firms.
- The reliance on large datasets raises concerns about protecting sensitive information, particularly in projects involving critical civil structure.
- Diverse software platforms and the absence of standardized data formats make it challenging to integrate AI and optimization techniques into existing workflows across the industry.
- While AI techniques show promise in simulations and controlled environments, translating these results to real-world conditions (e.g., seismic design) remains a significant challenge.
- Variations in material properties, environmental conditions, and human factors contribute to unpredictability, limiting the accuracy of AI-driven models.
- Evolving safety and compliance standards in civil engineering can slow down the adoption of new AI techniques, particularly in safety-critical applications.

Tab. 4 encapsulates the multifaceted limitations inherent in the optimization techniques discussed in this review work. Each reference enhances the overall comprehension of optimization in civil engineering while also presenting specific challenges related to model accuracy, generalizability, data dependency, and methodological constraints. Addressing these limitations requires ongoing research, interdisciplinary collaboration, and the development of more robust, adaptable computational models.

| References | Limitation Summary  |
|------------|---|
| [2]        | Sensitivity analysis may not fully account for the complex interactions between different structural elements under varying loads.          |
| [4]        | Experimental and data-driven approaches to crack characterization might not generalize to all types of concrete or damage scenarios.        |
| [29]       | The reliability-based approach might overlook some site-specific corrosion factors, affecting the accuracy of fragility curves.             |
| [30]       | Optimization of controlled rocking frames may not capture the full range of structural responses in highly dynamic seismic events.          |
| [32]       | Exploration may not encompass all emerging optimization methods, possibly missing some innovative approaches.                               |
| [36]       | Fuzzy cognitive maps might oversimplify the complex relationships between different factors influencing crack categorization.               |
| [37]       | Hybrid neuro-fuzzy models' predictions on concrete carbonation depth might not be accurate across different concrete compositions.          |
| [38]       | Data-driven models for displacement determination might not perform well in predicting outcomes for structures beyond the training dataset. |
| [39]       | The integration of BIM with advanced imaging might face challenges in data compatibility and processing capabilities.                       |
| [46]       | Potential discrepancies between model predictions and real-world seismic behaviors due to simplifications in the RSM.                       |
| [51]       | RSM may not accurately predict the shrinkage cracking behavior under all environmental conditions.  |

Table 4: Limitations in some previous work.



### *Global Sustainability and Decarbonization Targets*

As the world intensifies its focus on sustainability, civil engineering has a pivotal role in contributing to global efforts such as the Sustainable Development Goals (SDGs), especially SDG 9 (Industry, Innovation, and Infrastructure). The construction industry is responsible for approximately 38% of global CO<sub>2</sub> emissions (Global Status Report for Buildings and Construction, 2022), which underscores the urgent need for more sustainable building practices. AI-driven optimization techniques provide an opportunity to align civil engineering practices with decarbonization targets, enabling the design, construction, repair, and monitoring of civil structure that is not only efficient and resilient but also environmentally sustainable.

AI-driven optimization techniques also contribute to sustainability by improving resource efficiency. The use of methods like DOE allows for the precise adjustment of material proportions and construction processes, ensuring that resources are used optimally, thus reducing both waste and costs. These techniques enable engineers to simulate different scenarios and make data-driven decisions that minimize the environmental impact of construction projects. This is particularly important in large-scale civil structure projects where resource-intensive materials are involved.

AI's role in sustainability extends to the development of resilient civil structures that can withstand the impacts of climate change. Techniques such as fuzzy logic and neural networks can be used to design civil structures that are more adaptable to changing environmental conditions, ensuring longevity and reducing the need for frequent repairs and maintenance. This contributes to sustainability by reducing the overall resource demand and lifecycle emissions associated with civil structure maintenance and reconstruction.

By aligning AI optimization methods with global decarbonization and sustainability targets, the civil engineering sector can contribute significantly to reducing the environmental impact of civil structure development and repair techniques. This includes contributing to the net-zero emissions goals set by various countries and international organizations. Furthermore, integrating sustainability metrics into the design process will ensure that the future civil structure is both energy-efficient and capable of supporting low-carbon economies.

## **CONCLUSION AND RECOMMENDATIONS**

This review emphasizes the transformative potential of optimization methodologies in revolutionizing civil engineering. By integrating advanced computational techniques such as DOE, fuzzy logic, ANN, the field is progressing toward more adaptable, efficient, and cost-effective solutions for structural design, material optimization, and construction methodologies. These techniques have proven effective in handling uncertainties, enabling the development of a more resilient and sustainable civil structure while addressing modern challenges, including resource management and safety enhancement. The review highlights how these methods foster innovation, improve reliability, and contribute to the advancement of civil engineering. However, there remain several practical challenges that must be addressed for these optimization techniques to achieve widespread application. The integration of AI-driven methods into existing engineering workflows, the computational resources required, and concerns over data privacy and security are significant obstacles. Bridging the gap between theoretical advancements and real-world applications will require interdisciplinary collaboration and continuous technology to equip engineers with the necessary expertise.

Moving forward, several key areas of research and development should be prioritized. One necessary area is the development of more efficient computational algorithms. Reducing the computational load associated with AI and optimization techniques will make these tools more accessible, particularly to smaller engineering firms. This could be achieved by leveraging advancements in cloud computing, parallel processing, and algorithm optimization to reduce resource requirements.

Another essential direction for future research lies in improving the integration of AI techniques into traditional engineering workflows. Standardized frameworks and methodologies need to be developed to ensure the seamless application of AI tools alongside conventional practices. Interdisciplinary collaboration between AI experts and civil engineers will be instrumental in achieving this balance, ensuring that new technologies enhance rather than disrupt established practices.

As data privacy and security continue to be of growing importance in civil engineering projects, further research into secure data-sharing platforms and encryption techniques is necessary. AI systems generate vast amounts of data, especially when applied to critical civil structure constructions, making the protection of this information a top priority. Ensuring compliance with stringent regulatory standards will be essential for the broader acceptance of these techniques.

Sustainability is another key focus area for future work. AI-driven optimization techniques hold significant promises in reducing resource consumption, minimizing waste, and lowering carbon emissions. Aligning these methods with global sustainability targets will enable the construction industry to develop more eco-friendly civil structure while also improving



overall cost efficiency. Finally, further research is required to enhance the practical applications of AI in areas such as seismic design optimization and structural health monitoring. Real-world testing and validation of AI-driven models across various environmental conditions will help close the gap between theoretical progress and practical implementation. Expanding the scope of AI applications to explore new materials and sustainable civil structure techniques will push the boundaries of innovation in civil engineering, positioning the industry to tackle future challenges effectively.

## ACKNOWLEDGEMENT

The author, Asraa Anjum, gratefulness for the support from TFW2020 at the Kulliyah of Engineering, International Islamic University Malaysia. Additionally, the authors acknowledge the support Structures and Materials (S&M) Research Laboratory at Prince Sultan University.

## REFERENCES

- [1] Alhakeem, Z.M., Jebur, Y.M., Henedy, S.N., Imran, H., Bernardo, L.F.A., Hussein, H.M. (2022). Prediction of Ecofriendly Concrete Compressive Strength Using Gradient Boosting Regression Tree Combined with GridSearchCV Hyperparameter-Optimization Techniques, *Materials (Basel)*, 15(21), DOI: 10.3390/ma15217432.
- [2] Hooshmandi, S., Kioumars, B., Kioumars, M., Hajmohammadian Baghban, M. (2017). Application of response surface method (RSM) on sensitivity analysis of reinforced concrete bridge pier wall. *Proceedings of the XXIII Nordic Concrete Research Symposium*, pp. 1–4.
- [3] Tarighat, A. (2012). Fuzzy Inference System as a Tool for Management of Concrete Bridges, *Fuzzy Inference Syst. - Theory Appl.*, DOI: 10.5772/35751.
- [4] Das, S., Dutta, S., Adak, D., Majumdar, S. (2021). On the crack characterization of reinforced concrete structures: Experimental and data-driven numerical study, *Structures*, 30, pp. 134–145, DOI: 10.1016/j.istruc.2020.12.069.
- [5] Zhang, J.K., Yan, W., Cui, D.M. (2016). Concrete condition assessment using impact-echo method and extreme learning machines, *Sensors (Switzerland)*, 16(4), pp. 1–17, DOI: 10.3390/s16040447.
- [6] Szeptyński, P., Mikulski, L. (2023). Preliminary optimization technique in the design of steel girders according to Eurocode 3, *Arch. Civ. Eng.*, 69(1), pp. 71–89, DOI: 10.24425/ace.2023.144160.
- [7] Li, Y., Zhang, H., Wu, X., and Sun, L. (2024). Topology Optimization Methods for Geostucture Design: Application in Soil and Rock Structures, *J. Geotech. Eng.*, 150(6), pp. 1234–1250, DOI: 10.1061/(ASCE)GT.1943-5606.0002504.
- [8] García-Macías, E., Ubertaini, F. (2022). Real-time Bayesian damage identification enabled by sparse PCE-Kriging meta-modelling for continuous SHM of large-scale civil engineering structures, *J. Build. Eng.*, 59, DOI: 10.1016/j.jobbe.2022.105004.
- [9] Molaabasi, H., Hajitaheriha, M.M., Salahi, M., Li, J. (2024). Evaluation of Uncertainty in Shear-Wave Velocity Based on CPT Records Using the Robust Optimization Method, pp. 1–23, DOI: 10.22059/CEIJ.2024.366170.1969.
- [10] Rashidi Nasab, A., Elzarka, H. (2023). Optimizing Machine Learning Algorithms for Improving Prediction of Bridge Deck Deterioration: A Case Study of Ohio Bridges, *Buildings*, 13(6), DOI: 10.3390/buildings13061517.
- [11] Champiri, M.D., Hossein Mousavizadegan, S., Moodi, F. (2012). A decision support system for diagnosis of distress cause and repair in marine concrete structures, *Comput. Concr.*, 9(2), pp. 99–118, DOI: 10.12989/cac.2012.9.2.099.
- [12] Nair, A., Cai, C.S., Kong, X. (2020). Using Acoustic Emission to Monitor Failure Modes in CFRP-Strengthened Concrete Structures, *J. Aerosp. Eng.*, 33(1), pp. 04019110, DOI: 10.1061/(asce)as.1943-5525.0001106.
- [13] Taffese, W.Z. (2020). Data-driven method for enhanced corrosion assessment of reinforced concrete structures. 2020.
- [14] Torzoni, M., Tezzele, M., Mariani, S., Manzoni, A., Willcox, K.E. (2024). A digital twin framework for civil engineering structures, *Comput. Methods Appl. Mech. Eng.*, 418(PB), pp. 116584, DOI: 10.1016/j.cma.2023.116584.
- [15] Anjum, A., Hrairi, M., Aabid, A., Yatim, N., Ali, M. (2024). Civil structural health monitoring and machine learning: a comprehensive review, *Frat. Ed Integrità Strutt.*, 69, pp. 43–59, DOI: 10.3221/IGF-ESIS.69.04.
- [16] Babović, Z., Bajat, B., Đokić, V., Đorđević, F., Drašković, D., Filipović, N., Furht, B., Gačić, N., Ikodinović, I., Ilić, M., Irfanoglu, A., Jelenković, B., Kartelj, A., Klimeck, G., Korolija, N., Kotlar, M., Kovačević, M., Kuzmanović, V., Marinković, M., Marković, S., Mendelson, A., Milutinović, V., Nešković, A., Nešković, N., Mitić, N., Nikolić, B., Novoselov, K., Prakash, A., Ratković, I., Stojadinović, Z., Ustyuzhanin, A., Zak, S. (2023). Research in computing-intensive simulations for nature-oriented civil-engineering and related scientific fields, using machine learning and big data: an overview of open problems, *J. Big Data*, 10(1), DOI: 10.1186/s40537-023-00731-6.



- [17] Ujong, J.A., Mbadike, E.M., Alaneme, G.U. (2022). Prediction of cost and duration of building construction using artificial neural network, *Asian J. Civ. Eng.*, 23(7), pp. 1117–1139, DOI: 10.1007/s42107-022-00474-4.
- [18] Pradeep, T., GuhaRay, A., Bardhan, A., Samui, P., Kumar, S., Armaghani, D.J. (2022). Reliability and Prediction of Embedment Depth of Sheet pile Walls Using Hybrid ANN with Optimization Techniques, *Arab. J. Sci. Eng.*, 47(10), pp. 12853–12871, DOI: 10.1007/s13369-022-06607-w.
- [19] Wakjira, T.G., Kutty, A.A., Alam, M.S. (2024). A novel framework for developing environmentally sustainable and cost-effective ultra-high-performance concrete (UHPC) using advanced machine learning and multi-objective optimization techniques, *Constr. Build. Mater.*, 416, pp. 135114, DOI: 10.1016/j.conbuildmat.2024.135114.
- [20] Kaveh, A., Zaerreza, A. (2022). Enhanced Rao Algorithms for Optimization of the Structures Considering the Deterministic and Probabilistic Constraints, *Period. Polytech. Civ. Eng.*, 66(3), pp. 694–709, DOI: 10.3311/PPci.20067.
- [21] Khajehzadeh, M., Keawsawasvong, S., Sarir, P., Khailany, D.K. (2022). Seismic Analysis of Earth Slope Using a Novel Sequential Hybrid Optimization Algorithm, *Period. Polytech. Civ. Eng.*, 66(2), pp. 355–366, DOI: 10.3311/PPci.19356.
- [22] Salimi, P., Bondarabadi, H.R., Kaveh, A. (2022). Optimal Design of Reinforced Concrete Frame Structures Using Cascade Optimization Method, *Period. Polytech. Civ. Eng.*, 66(4), pp. 1220–1233, DOI: 10.3311/PPci.20868.
- [23] Wang, X., Wu, J., Yin, X., Liu, Q., Huang, X., Pan, Y., Yang, J., Huang, L., Miao, S. (2023). QPSO-ILF-ANN-based optimization of TBM control parameters considering tunneling energy efficiency, *Front. Struct. Civ. Eng.*, 17(1), pp. 25–36, DOI: 10.1007/s11709-022-0908-z.
- [24] Vu, P., Son, H., Ngoc, L., Khoi, Q. (2023). Optimization in Construction Management Using Adaptive Opposition Slime Mould Algorithm.
- [25] Khan, N., Zaidi, S.F.A., Yang, J., Park, C., Lee, D. (2023). Construction Work-Stage-Based Rule Compliance Monitoring Framework Using Computer Vision (CV) Technology, *Buildings*, 13(8), DOI: 10.3390/buildings13082093.
- [26] Son, P.V.H., Souliisa, F.V. (2023). A Hybrid Ant Lion Optimizer (ALO) Algorithm for Construction Site Layout Optimization, *J. Soft Comput. Civ. Eng.*, 7(4), pp. 50–71, DOI: 10.22115/SCCE.2023.365303.1540.
- [27] Aabid, A., Hrairi, M., Ali, J.S.M. (2024). Optimization of damage repair with piezoelectric actuators using the Taguchi method, *Frat. Ed Integrita Strutt.*, 67, pp. 137–152, DOI: 10.3221/IGF-ESIS.67.10.
- [28] Lazić, L. (2013). Use of Orthogonal Arrays and Design of Experiments via Taguchi methods in Software Testing, *Recent Adv. Appl. Theor. Math.*, pp. 256–267.
- [29] Cavaco, E.S., Neves, L.A.C., Casas, J.R. (2017). Reliability-based approach to the robustness of corroded reinforced concrete structures, *Struct. Concr.*, 18(2), pp. 316–325, DOI: 10.1002/suco.201600084.
- [30] Moradi, S., Burton, H. V. (2018). Response surface analysis and optimization of controlled rocking steel braced frames, *Bull. Earthq. Eng.*, 16(10), pp. 4861–4892, DOI: 10.1007/s10518-018-0373-1.
- [31] Abdulridha, M.A., Banyhussan, Q.S. (2021). Effect polypropylene of fiber on drying shrinkage cracking of concrete pavement using response surface methodology, *J. Eng. Sustain. Dev.*, 25(03), pp. 10–21.
- [32] Mei, L., Wang, Q. (2021). Structural optimization in civil engineering: A literature review, *Buildings*, 11(2), pp. 1–28, DOI: 10.3390/buildings11020066.
- [33] Gajzler, M. (2013). The idea of knowledge supplementation and explanation using neural networks to support decisions in construction engineering, *Procedia Eng.*, 57, pp. 302–309, DOI: 10.1016/j.proeng.2013.04.041.
- [34] Bilgehan, M. (2011). A comparative study for the concrete compressive strength estimation using neural network and neuro-fuzzy modelling approaches, *Nondestruct. Test. Eval.*, 26(1), pp. 35–55, DOI: 10.1080/10589751003770100.
- [35] Tarighat, A. (2012). Fuzzy Inference System as a Tool for Management of Concrete Bridges. *Fuzzy Inference System - Theory and Applications*, pp. 445–470.
- [36] Senniappan, V., Subramanian, J., Papageorgiou, E.I., Mohan, S. (2017). Application of fuzzy cognitive maps for crack categorization in columns of reinforced concrete structures, *Neural Comput. Appl.*, 28, pp. 107–117, DOI: 10.1007/s00521-016-2313-9.
- [37] Malami, S.I., Anwar, F.H., Abdulrahman, S., Haruna, S.I., Ali, S.I.A., Abba, S.I. (2021). Implementation of hybrid neuro-fuzzy and self-turning predictive model for the prediction of concrete carbonation depth: A soft computing technique, *Results Eng.*, 10(April), pp. 100228, DOI: 10.1016/j.rineng.2021.100228.
- [38] Khademi, F., Akbari, M., Nikoo, M. (2017). Displacement determination of concrete reinforcement building using data-driven models, *Int. J. Sustain. Built Environ.*, 6(2), pp. 400–411, DOI: 10.1016/j.ijbsbe.2017.07.002.
- [39] Chan, B., Guan, H., Hou, L., Jo, J., Blumenstein, M., Wang, J. (2016). Defining a conceptual framework for the integration of modelling and advanced imaging for improving the reliability and efficiency of bridge assessments, *J. Civ. Struct. Heal. Monit.*, 6(4), pp. 703–714, DOI: 10.1007/s13349-016-0191-6.
- [40] Luleci, F., Catbas, F.N., Avci, O. (2022). CycleGAN for Undamaged-to-Damaged Domain Translation for Structural Health Monitoring and Damage Detection, pp. 1–27.
- [41] Sonebi, M., Cevik, A., Grünwald, S., Walraven, J. (2016). Modelling the fresh properties of self-compacting concrete



- using support vector machine approach, *Constr. Build. Mater.*, 106, pp. 55–64, DOI: 10.1016/j.conbuildmat.2015.12.035.
- [42] Chen, W., Xu, J., Dong, M., Yu, Y., Elchalakani, M., Zhang, F. (2021). Data-driven analysis on ultimate axial strain of FRP-confined concrete cylinders based on explicit and implicit algorithms, *Compos. Struct.*, 268, pp. 113904, DOI: 10.1016/j.compstruct.2021.113904.
- [43] Al-Ghalib, A.A., Mohammad, F.A. (2016). Damage and repair classification in reinforced concrete beams using frequency domain data, *Mater. Struct. Constr.*, 49(5), pp. 1893–1903, DOI: 10.1617/s11527-015-0621-7.
- [44] Gui, G., Pan, H., Lin, Z., Li, Y., Yuan, Z. (2017). Data-driven support vector machine with optimization techniques for structural health monitoring and damage detection, *KSCE J. Civ. Eng.*, 21(2), pp. 523–534, DOI: 10.1007/s12205-017-1518-5.
- [45] Elhegazy, H., Chakraborty, D., Elzarka, H., Ebid, A.M., Mahdi, I.M., Aboul Haggag, S.Y., Abdel Rashid, I. (2022). Artificial Intelligence for Developing Accurate Preliminary Cost Estimates for Composite Flooring Systems of Multi-Storey Buildings, *J. Asian Archit. Build. Eng.*, 21(1), pp. 120–132, DOI: 10.1080/13467581.2020.1838288.
- [46] Hu, S., Chen, B., Song, G., Wang, L. (2021). Resilience-based seismic design optimization of typical highway RC bridges by response surface method and NSGA-II algorithm, *Bull. Earthq. Eng.*, pp. 1–26.
- [47] Khajehzadeh, M., Taha, M.R., Keawsawasvong, S., Mirzaei, H., Jebeli, M. (2022). An Effective Artificial Intelligence Approach for Slope Stability Evaluation, *IEEE Access*, 10, pp. 5660–5671, DOI: 10.1109/ACCESS.2022.3141432.
- [48] Ansari, R., Khalilzadeh, M., Hosseini, M.R. (2022). A Multi-objective Dynamic Optimization Approach to Project Schedule Management: A Case Study of a Gas Field Construction, *KSCE J. Civ. Eng.*, 26(3), pp. 1005–1013, DOI: 10.1007/s12205-021-0410-5.
- [49] Anjum, A., Hrairi, M., Aabid, A., Yatim, N., Ali, M. (2024). Damage detection in concrete structures with impedance data and machine learning, *Bull. Polish Acad. Sci. Tech. Sci.*, 72(3), pp. 1–11, DOI: 10.24425/bpasts.2024.149178.
- [50] Li, X., Zhang, X., Zhang, Y. (2024). A limit analysis-based topology optimisation method for geostructure design, *Comput. Geotech.*, 169, pp. 106239, DOI: 10.1016/j.compgeo.2024.106239.
- [51] Abdulridha, M.A., Salman, M.M., Banyhussan, Q.S. (2021). Effect Polypropylene of Fiber on Drying Shrinkage Cracking of Concrete Pavement Using Response Surface Methodology, *J. Eng. Sustain. Dev.*, 25(3), pp. 10–21, DOI: 10.31272/jeasd.25.3.2.

## ABBREVIATION

|         |                                       |
|---------|---------------------------------------|
| AI      | Artificial Intelligence               |
| FL      | Fuzzy Logic                           |
| DOE     | Design of Experiments                 |
| ANN     | Artificial Neural Networks            |
| SHM     | Structural Health Monitoring          |
| RSM     | Response Surface Methodology          |
| FOS     | Factor of Safety                      |
| CFRP    | Carbon Fiber Reinforced Polymer       |
| MSE     | Mean Squared Error                    |
| BAMS    | Bridge Asset Management System        |
| UHPC    | Ultra-High-Performance Concrete       |
| GBRT    | Gradient Boosting Regression Tree     |
| ANFIS   | Adaptive Neuro-Fuzzy Inference System |
| MLR     | Multiple Linear Regression            |
| EPR     | Evolutionary Polynomial Regression    |
| XGBoost | Extreme Gradient Boosting             |