

FOSTERING CUSTOMER LOYALTY AMONG MUSLIM CLIENTS: STRATEGIES FOR ISLAMIC BANKS

RONI ANDESPA

Department of Sharia Business Management
Faculty of Islamic Economics and Business, Universitas Islam
Negeri Imam Bonjol, 25171 Padang, Indonesia
Email: roniandespa@uinib.ac.id

YULIA HENDRI YENI

Department of Management, Faculty of Economics and Business
Universitas Andalas, 25163 Padang, Indonesia
Email: yuliahendriyeni@eb.unand.ac.id

Received on: 04-08-22

Accepted on: 04-03-24

<https://doi.org/10.57144/hi.v47i1.499>

Abstract

This research examines the influence of service quality, corporate image, customer satisfaction, and customer engagement on loyalty in Islamic banks. The study was conducted by distributing questionnaires to 500 randomly selected West Sumatra, Indonesia respondents. This research uses Structural Equation Model Analysis. The findings of this study show that service quality and company image significantly affect customer satisfaction at Islamic banks. It is indicated that service quality and company image significantly and positively impact customer engagement. It is found that all determinant factors, directly and indirectly, affect customer loyalty to Islamic banks. From the results of this study, it is expected that Islamic bank executives must identify the elements that influence customer loyalty because these factors directly or indirectly affect the customer loyalty variable. The results of this study can be used as a consideration for Islamic bank managers in developing marketing strategies because they are closely related to the marketing performance managers need to control the service performance of Islamic banks. Theoretically, this research is also a new reference for researchers studying Islamic banks. Further researchers can adapt the model and variable indicators in this study, which can be applied further.

Keywords: *Islamic Banks; Determining Factors; Customer Loyalty;*

*SEM Analysis***1. Introduction**

Islamic banks operate with a distinct system from conventional banking, holding significant market potential for the future. The policies enacted by the Indonesian government concerning Islamic Commercial Banks are anticipated to expedite the growth of Islamic financial institutions in Indonesia, particularly in West Sumatra.¹ With a predominantly Muslim population, West Sumatra Province is poised for swifter Islamic bank development than other regions. Given their religious adherence, the populace of West Sumatra should favour Islamic banks. Nonetheless, previous research indicates that the advancement of Islamic banks in West Sumatra remains limited. Consequently, Islamic banking managers are urged to enhance efforts to attract more customers to engage in transactions through Islamic banking channels.

The growth of Islamic banks' gross assets, financing, and savings in West Sumatra lags behind that of neighbouring provinces. The following figure illustrates Islamic banks' gross assets, funding, and depositor funds in Nanggroe Aceh Darussalam, North Sumatra, West Sumatra, Riau, and South Sumatra. It indicates that the progress of Islamic banks in West Sumatra remains notably lower compared to other provinces.

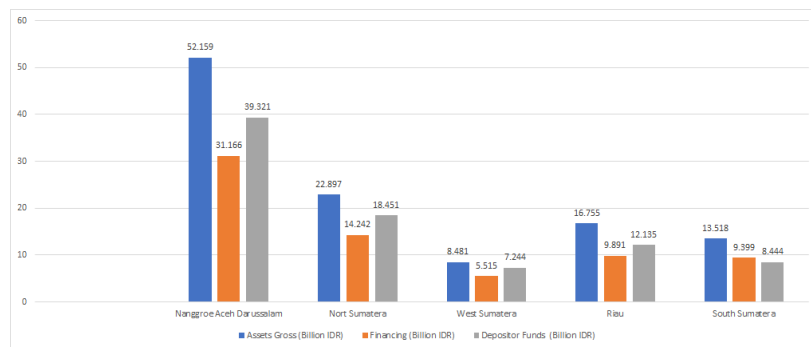

Figure 1: The development of Islamic banks in Nanggroe Aceh Darussalam, North Sumatra, West Sumatra, Riau and South Sumatra²

Bank executives must devise strategies to acquire and retain new customers.^{3,4} To ensure the rapid development of Islamic banks in West Sumatra, innovative and creative approaches based on customer needs must be implemented when Islamic bank managers develop strategies to expand and maintain current markets. In formulating these strategies, Islamic bank managers must recognize

that the current market demand is excellent service. Therefore, Islamic bank managers must understand that one effective method is to offer satisfactory services, which will later assist in recruiting new customers and retaining existing ones.⁵ It means that the most important thing Islamic bank managers do is to create customer loyalty.

Customer loyalty is considered the primary factor determining profitability. Many companies adopt this as a strategy to boost profits. Customer loyalty in the Islamic financial industry measures the extent to which customers make Islamic finance their main choice in managing their finances. Customer engagement is one indicator of success in creating customer loyalty to the bank.⁶ When a business successfully fosters long-term customer engagement, customers become loyal to the company.⁷ Islamic banks must be able to foster interaction and communication with their customers. Strong relationships between banks and consumers will keep customers continuously choosing the company's products or services.^{8,9}

Every Islamic bank manager must work hard to ensure that customers are pleased with the service they receive from the company.^{10,11} However, providing excellent service to all customers is not easy for every Islamic bank manager.¹² Satisfaction and loyalty are two things that can be influenced by the excellent service provided by the bank.^{13,14,15} Companies that offer high-quality service will generate high customer satisfaction and ultimately increase customer loyalty.¹⁶

Customers not only desire excellent service from Islamic banks but also expect these banks to have an outstanding corporate image.¹⁷ An excellent corporate image motivates customers to opt for transactions at Islamic banks. Previous research has elucidated that corporate image is another crucial factor influencing customer satisfaction and loyalty.^{18,19} However, establishing a positive impression of Islamic banks among customers is challenging. According to experts, corporate image significantly affects the loyalty of Islamic bank clients, as customers feel reassured when dealing with a reputable organization.²⁰

The research gap in this article lies in the need to further explore the interaction among the determinants of loyalty, such as service quality, corporate image, customer satisfaction, and customer engagement within the context of Islamic banking. While many previous studies have investigated these factors separately, there is still a lack of understanding of how these factors interact and influence each other in shaping the loyalty of Muslim customers in Islamic banks. Research delving into this interaction aspect will

provide deeper insights into the most influential factors in creating and maintaining customer loyalty in the Islamic banking environment. Therefore, research exploring the interaction among these factors will remain relevant and provide valuable contributions to advancing knowledge in management and banking, particularly in Islamic banking.

The benefit of the findings of this article for the future sustainability of Islamic finance lies in how it elucidates strategies for fostering loyalty among Muslim customers in Islamic banks. Islamic financial institutions can develop more effective strategies to retain and attract new customers by comprehending the factors influencing customer loyalty. It can contribute to the overall growth of Islamic banking businesses, strengthen the stability of Islamic finance, and broaden access to financial services aligned with *Shari'ah* principles for Muslim communities. Thus, the findings of this research have significant implications for the sustainability and growth of the Islamic finance industry in the future.

The structure of this paper consists of several crucial sections. It commences with an introduction, elucidating the scope and objectives of the research. The literature review follows the introduction, where relevant research and theories are examined and critically analyzed. Next is the methodology section, detailing the approach and methods employed in conducting the study. Subsequently, the results section presents the findings obtained from the research process, often accompanied by data analysis and interpretation. Additionally, there is a discussion section where the implications of the findings are explored. Finally, there is the conclusion and future research section.

2. Literature review

2.1. Customer loyalty (CL)

One of the indicators of the success of Islamic Bank's marketing programs is having many loyal customers.²¹ Customer loyalty is the behaviour of customers who regularly purchase from a company and continue to do so.²² Creating loyal customers is an important task for every Islamic bank manager. However, fostering loyal customers is challenging due to numerous competitors operating in the financial sector. The goal of retaining loyal customers is to enable them to support the company's growth in various conditions and situations. Furthermore, if a company has many loyal customers, these customers will promote the company's products and reduce the promotional costs incurred by the company. Consequently, company managers employ various strategies to retain customers.^{23,24}

Customer loyalty is an intriguing variable to explore, particularly in Islamic banks. Many methods can be used to measure the level of customer loyalty.²⁵ Previous research indicates that indicators of customer loyalty include repeat purchases, recommending the company to others, promoting products to close contacts, and not wanting to switch to other companies.^{26,27} Based on previous findings, it can be concluded that loyal customers are not interested in products offered by other companies and do not want to switch to other banks.^{28,29} Previous experts have stated that loyal customers of Islamic banks feel that the bank where they deposit/borrow money is the best.^{30,31}

2.2. Customer engagement (CE)

Customer engagement, the interaction between Islamic banks and their customers, is vital to communication.^{32,33} In business, customer engagement refers to the relationship or communication between a company and its customers. It can arise from customers' interactions, emotions, and overall experiences with the banking services they choose to use.³⁴ Managers can build connections and interactions with all Islamic Bank customers using various methods and communication channels.³⁵ Customer engagement in marketing activities can be done face-to-face or through electronic media.^{36,37} Effective communication and interaction between the company and customers contribute to the success of a business.³⁸ Customer engagement occurs when a company and its customers are deeply connected.³⁹ Indicators of customer engagement include good communication, enthusiasm for using services, positive feelings towards service providers, and active service usage.⁴⁰

Customers make purchases and feel like they are part of the company. When bank staff connect well with consumers, Islamic bank managers indirectly bring their customers closer to the company.⁴¹ Company-customer closeness fosters customer loyalty.⁴² Consumers who have a good relationship and communication with the company are loyal customers.⁴³ Islamic bank managers must create customer engagement to maintain customer loyalty.⁴⁴ Based on previous research findings, it is known that customer engagement directly influences customer loyalty.⁴⁵ Experts have studied the correlation between customer engagement and loyalty.⁴⁶ Thus, the researcher's hypothesis is:

H1: Customer loyalty is directly affected by customer engagement.

2.3. Customer satisfaction (CS)

Customer satisfaction is the gratification customers feel after purchasing a product or receiving a service from a company.⁴⁷ Customers attain this satisfaction when they compare their service

expectations with the actual performance of the purchased service.⁴⁸ Consequently, customer satisfaction is subjective; the degree of satisfaction varies depending on individual consumers. Companies must survey whether their offerings meet customer expectations to determine whether customers are satisfied.^{49,50} Surveys are conducted to assess the disparity between customer expectations and experiences.⁵¹ If customers are dissatisfied, the company's performance suffers.⁵²

Research on customer satisfaction in an organization is not something new. However, research still needs to be conducted to examine customer satisfaction, particularly in Islamic banks.⁵³ Essential factors like customer satisfaction are crucial for Islamic bank managers to ensure smooth company operations.⁵⁴ When company customers feel satisfied, the company will benefit financially and non-financially.⁵⁵ Customer satisfaction also determines a company's performance.⁵⁶ If a company has satisfied customers, its performance is deemed good.^{57,58}

Customer satisfaction plays a crucial role in driving loyalty across various industries.^{59,60} Research in the hospitality, tourism, and healthcare sectors consistently highlights the strong correlation between satisfaction levels and customer loyalty.⁶¹ For instance, studies in the hospitality industry have indicated that satisfied guests tend to exhibit loyalty to specific hotels. Similarly, satisfied tourists are inclined to remain loyal to destinations or service providers within the tourism sector.^{62,63} This trend extends to the healthcare industry, where satisfied patients often maintain loyalty to healthcare providers.^{64,65}

The relationship between customer satisfaction and loyalty remains a subject of significant investigation within Islamic banking. Previous research in Islamic banks has shown that customer satisfaction influences customer engagement.⁶⁶ It has been observed that satisfied customers are more likely to engage with Islamic banks and maintain long-term relationships. Therefore, understanding and enhancing customer satisfaction is crucial for fostering loyalty and engagement within Islamic banking institutions.^{67,68} Thus, the research hypothesis is:

H2: Customer loyalty is directly and indirectly affected by customer satisfaction.

H3: Customer engagement is directly affected by customer satisfaction.

2.4. Service quality (SQ)

Many previous researchers have extensively examined the relationship between service indicators and customer satisfaction.^{69,70,71} Their studies have consistently demonstrated a significant and robust influence of service quality and satisfaction variables on customer loyalty.⁷² Customer satisfaction is achieved when a company provides services that meet or exceed customer expectations, enhancing loyalty. Experts affirm that excellent service from an Islamic bank satisfies customers and positively impacts their loyalty.^{73,74,75}

Islamic bank managers must analyze the impact of service quality on customer engagement. It's observed that service quality indirectly affects customer engagement, as customers are more likely to engage with a company that provides excellent service.⁷⁶ Moreover, a strong correlation between service quality and customer engagement suggests that better service fosters stronger customer-company relationships.⁷⁷ Service quality encompasses all activities undertaken by a company to meet customer expectations, and it significantly influences customer loyalty.^{78,79,80} Extensive research by academics confirms that excellent service leads to customer satisfaction, which, in turn, cultivates loyalty among customers.^{81,82}

Thus, the research hypothesis is:

H4: Customer satisfaction is directly affected by service quality.

H5: Customer engagement is directly and indirectly affected by service quality.

H6: Customer loyalty is directly and indirectly affected by service quality.

2.5. Corporate image (CI)

One of the most critical aspects of an Islamic bank is its corporate image.⁸³ It encompasses the consumer's perception of the company from which they purchase products or services.⁸⁴ Company managers gain significant benefits when customers have a positive impression of the company, thereby increasing the chances of acquiring satisfied customers.⁸⁵ Numerous previous studies have delved into the relationship between corporate image and customer satisfaction, particularly within the banking sector.⁸⁶ Experts have conducted thorough examinations of banks and have found that a positive corporate image contributes to customer satisfaction.^{87,88}

A reputable company is more likely to foster greater customer engagement.⁸⁹ Positive perceptions of the company's image are directly linked to increased customer engagement.⁹⁰ Therefore, Islamic bank managers must closely examine indicators of corporate image, as it significantly influences customer engagement. Previous

researchers have established a strong correlation between corporate image and customer engagement.^{91,92}

A positive corporate image benefits the company in terms of customer engagement and influences customer behaviour.⁹³ Satisfied customers are more inclined to recommend the company's products or services to others, while dissatisfied customers may spread negative information about the company.⁹⁴ Customer loyalty can be fostered through an excellent corporate image, as customers who perceive Islamic banks positively are likelier to remain loyal to them.⁹⁵ Previous research has consistently shown that the company's image is pivotal in determining customer loyalty. Therefore, the research hypothesis is:

H7: Customer satisfaction is directly affected by corporate image.

H8: Customer engagement is directly and indirectly affected by corporate image.

H9: Customer loyalty is directly and indirectly affected by corporate image.

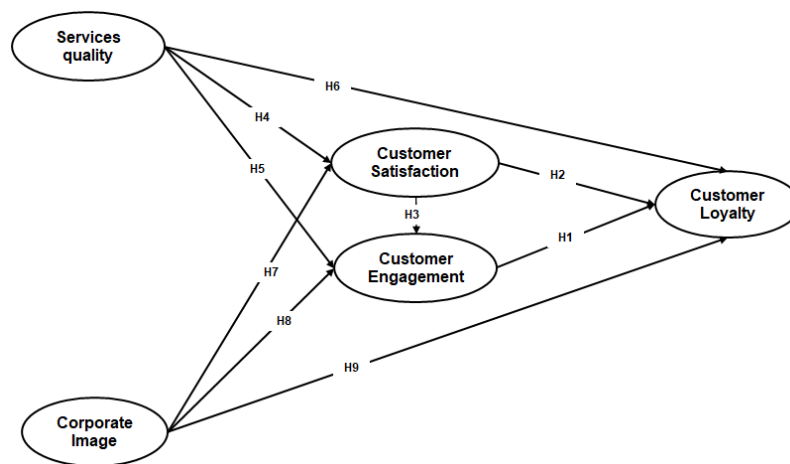

Figure 2: Research framework

The figure above depicts the research framework designed by the researcher, illustrating the relationship between variables. This framework was developed based on the literature review, previous research findings, and observed phenomena in the field.

3. Methodology

3.1. Population and sample

The study included all active customers of Islamic banks in West Sumatera, encompassing areas such as Padang, Bukittinggi, Batusangkar, Payakumbuh, Solok, and Pariaman. A questionnaire comprising 22 items was utilized for data collection. The total number

of research items was multiplied by 5-20 to determine the minimum sample size.⁹⁶ Consequently, the minimum required sample size was calculated to be 440. However, the total number of research respondents exceeded this minimum requirement, reaching 500 participants.

3.2. Measurement development

Measurement development was accomplished by adapting relevant research conducted by previous researchers. This approach allows researchers to refine their focus and uncover specific issues within the study. The researcher adapted the measurement of the customer loyalty variable from ⁹⁷ and ⁹⁸. Customer satisfaction variable from ⁹⁹ and ¹⁰⁰. The variable customer engagement of adaptation researchers from ¹⁰¹ and ¹⁰². Quality of service variable from ¹⁰³ and ¹⁰⁴. And corporate image variable from ¹⁰⁵ and ¹⁰⁶.

3.3. Data collection procedure

In developing the research questionnaire, the researcher utilized a five-point Likert scale ranging from Very Disagree to Very Agree for all indicator variables except customer satisfaction. The section on customer satisfaction utilized a five-point Likert scale from Very Dissatisfied to Very Satisfied. Following this, a trial was conducted with 90 respondents. Subsequently, the questionnaire was distributed to 500 active customers in West Sumatra, Indonesia.

3.4. Construct reliability and validity

The next step involves measuring the validity and reliability of the research instrument. Testing validity and reliability assures researchers that the questionnaire is dependable and accurate in assessing research issues. Several criteria were considered to achieve this. These include ensuring a Loading Factor (LF) of more than 0.5 for all questionnaire items, an Average Variance Extract (AVE) value exceeding 0.5 for the study construct, α (Cronbach's alpha) greater than 0.7, and a Composite Reliability (CR) score above 0.7 for all questionnaire questions.¹⁰⁷ After fulfilling all these requirements, it was determined that all research constructs and questionnaire items were valid and reliable. The data below outlines the LF, α , AVE, and CR test results.

Indicators		LF	α	AVE	CR
Services quality (SQ)			0.855	0.557	0.900
SQ1	Islamic banks have adequate facilities.	0.906			
SQ2	Islamic bank employees empathize with customers.	0.701			

SQ3	Islamic banks respond to customer complaints and requests.	0.668			
SQ4	Islamic bank employees are reliable in their work.	0.819			
SQ5	Islamic banks provide a sense of security for customers.	0.598			
Corporate image (CI)			0.846	0.538	0.894
CI1	Customers are interested in Islamic bank services.	0.896			
CI2	Islamic banks have a good reputation.	0.692			
CI3	Islamic banks continually improve services.	0.579			
CI4	Islamic banks innovate sustainably.	0.824			
CI5	Agreements between Islamic banks and customers are different from other banks.	0.627			
Customer satisfaction (CS)			0.858	0.659	0.926
CS1	Islamic banks have excellent service.	0.977			
CS2	Islamic banks have a service system that is per customer expectations.	0.641			
CS3	Islamic banks have technology that is to customer expectations.	0.612			
CS4	Customers are satisfied with transaction fees at Islamic banks.	0.947			
Customer engagement (CE)			0.821	0.567	0.884
CE1	Customers have good communication with Islamic banks.	0.919			
CE2	Customers are enthusiastic about using Islamic bank services.	0.654			
CE3	Customers have positive feelings towards Islamic banks.	0.561			
CE4	Islamic banks use many media to communicate with customers.	0.825			

Customer loyalty (CL)			0.857	0.647	0.923
CL1	Customers encourage people to use Islamic banking.	0.959			
CL2	Customers intend to take advantage of Islamic banking services in the future.	0.660			
CL3	The customer recommends that others use the services of an Islamic bank.	0.639			
CL4	Customers will not use services provided by non-Islamic banks.	0.908			

Table 1: Reliability and validity test
Source: Output SEM AMOS

3.5. The Goodness of Fit Model

In Structural Equation Model (SEM) analysis, researchers must assess the model's fit to proceed to the next stage. Fit testing helps determine whether the proposed theoretical model aligns well with the collected data.

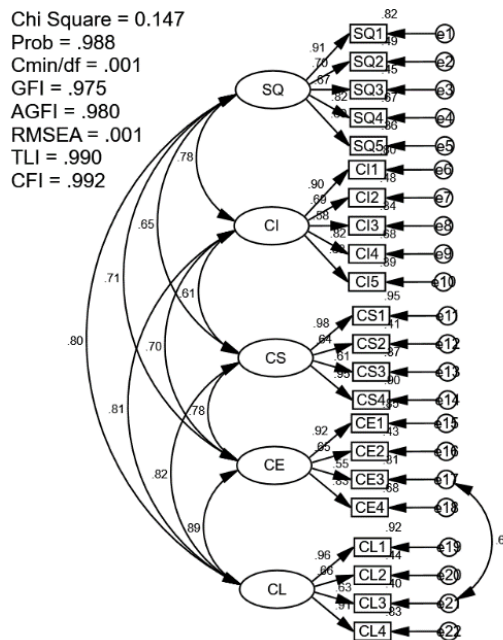

Figure 3: Goodness of fit model

The model is considered suitable if it meets predefined criteria.¹⁰⁸ The evaluation of model fit after modification is as

follows: The Chi-Square value is close to 0 (0.147), the probability value is $0.988 \geq 0.05$, the CMIN/DF value is $0.001 \leq 2.00$, the GFI value is $0.975 \geq 0.90$, the AGFI value is $0.980 \geq 0.90$, the RMSEA value is $0.001 \leq 0.08$, the TLI value is $0.990 \geq 0.90$, and the CFI value is $0.992 \geq 0.90$. Based on these data, the research model is deemed feasible as it meets the established criteria.

4. Results

4.1. Respondent demographics

Most of the studied customers were male, accounting for 52.4%. The largest proportion of respondents fell within the age group of 31-40 years old, comprising 31.3% of the sample. Regarding education level, most respondents were undergraduates, constituting 42%. The highest proportion of job respondents came from the private sector, making up 36% of the sample. Additionally, the highest customer experience level observed was 9-13 years, representing 45% of the respondents.

Profile		N	%
Gender	Male	262	52.4
	Female	238	47.6
Age	≤ 20	70	16
	21-30	125	30
	31-40	160	31.3
	≥ 40	145	22.7
Education Level	High school	80	16
	Associate degree	112	22.4
	Undergraduate degree	210	42
	Postgraduate	98	19.6
Occupation	Government sector	125	25
	Private sector	180	36
	Self-Employed	165	33
	Others	30	6
Customer experience	≤ 3	40	8
	4-8	140	28
	9-13	225	45
	≥ 14	95	19

Table 2: Respondent demographics

Source: Author's calculations

This finding also illustrates that most Islamic bank customers have been using the services for an extended period, which can influence their perceptions and expectations regarding service quality and the relationship with the bank. Information about the profile and experience of Islamic bank customers can provide

valuable insights for service providers in developing more effective marketing¹⁰⁹ and service strategies. For example, service providers can tailor their communications and offerings to better align with these demographic needs and preferences by understanding that most Islamic bank customers come from the private sector or have a bachelor's degree background. Additionally, knowing that most Islamic bank customers have long-standing experience, bank managers can focus on maintaining solid relationships with loyal customers.^{110,111}

4.2. Structural model

The researcher then proceeded to the subsequent investigation stage, the Structural Equation Model (SEM) analysis. The structural model analyses the relationship between variables and indicators, and subsequently between one variable and another, to obtain a comprehensive research model.

Constructs			Estimate
CS	←	SQ	0.433
CS	←	CI	0.276
CE	←	CI	0.230
CE	←	SQ	0.196
CE	←	CS	0.516
CL	←	SQ	0.163
CL	←	CI	0.241
CL	←	CS	0.224
CL	←	CE	0.435

Table 3: Standardized regression weights
Source: Output SEM AMOS

The researcher proceeded by testing the regression among the research variables. After processing the research data, the results revealed the regression values between the research variables. The table above illustrates that the service quality variable positively influences customer satisfaction, with a regression coefficient of 0.433. These findings suggest that the corporate image variable statistically positively affects customer satisfaction, with an estimated value of 0.276. The parameter estimates for assessing the impact of corporate image on the customer engagement variable yield an estimated value of 0.230, indicating a positive effect. The regression analysis depicted above demonstrates an estimated value of 0.196, signifying that the service quality variable statistically positively influences the customer engagement variable. According to the regression analysis results above, the regression coefficient value is 0.516, suggesting that the customer satisfaction variable positively impacts customer engagement.

The discussion of these findings highlights several important considerations for further examination. Firstly, service quality has a significant favourable influence on customer satisfaction. It underscores the importance for Islamic banks to continuously enhance the quality of services they offer customers in terms of service delivery and products.¹¹² Secondly, corporate image also has a substantial impact on customer satisfaction. Therefore, managers of Islamic banks demand scrutiny of how the community perceives their bank and how this perception can affect customer satisfaction.¹¹³

Thirdly, the findings also indicate that customer satisfaction positively impacts customer engagement. It suggests that customer satisfaction is crucial for retaining existing customers and increasing their engagement with the bank. It emphasizes the importance of prioritizing customer satisfaction in the business strategy of Islamic banks.¹¹⁴ Finally, this research provides a comprehensive view of the factors influencing the relationship between Islamic banks and their customers. Islamic banks can strengthen customer relationships and achieve long-term success by effectively understanding and managing these variables.¹¹⁵

The estimated value for evaluating the effect of the service quality variable on the customer loyalty variable is 0.163, indicating that service quality positively affects customer loyalty. The regression coefficient value representing the influence of the corporate image variable on the customer loyalty variable is 0.241, showing a positive impact of corporate image on loyalty. The regression value between customer satisfaction and loyalty variables is 0.224, indicating that customer satisfaction positively influences loyalty. Additionally, the regression coefficient value of the customer engagement variables on customer loyalty is 0.435, suggesting that customer engagement positively impacts customer loyalty.

The quality of service, corporate image, customer satisfaction, and customer engagement remain critical drivers of customer loyalty within Islamic banking. It underscores the significance of these factors in fostering enduring relationships with customers by Islamic principles.¹¹⁶ Management within Islamic banks can utilize these findings to bolster customer loyalty while adhering to Islamic values. They may concentrate on enhancing service quality in alignment with Islamic tenets, fortifying the company's image through principles of justice and compliance, ensuring heightened customer satisfaction by offering *Shari'ah*-compliant products and services, and actively promoting customer engagement in activities that espouse Islamic values.¹¹⁷

Moreover, these findings underscore the necessity for marketing and customer service strategies to strengthen customer relationships within the *Shari'ah* framework. Islamic banks must ensure their marketing and customer service endeavours align with *Shari'ah* principles. It involves enhancing the customer experience with halal and *Shari'ah*-compliant offerings, fostering effective communication utilizing language consistent with Islamic values, and cultivating deep-seated relationships while considering Islamic business's ethical and moral dimensions¹¹⁸.

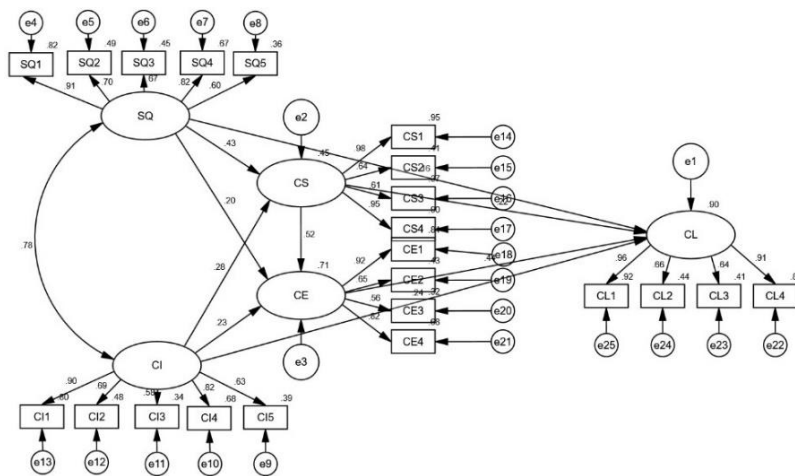

Figure 4: Structural model

4.3. Influence value between research variables

The table below presents the AMOS output, illustrating the influence values between research variables. The direct, indirect, and total effects of the research variables are as follows:

Constructs			Direct effect	Indirect effect	Total Effect
CI	→	CS	0.276	0.000	0.276
CI	→	CE	0.230	0.143	0.373
CI	→	CL	0.241	0.224	0.465
SQ	→	CS	0.433	0.000	0.433
SQ	→	CE	0.196	0.224	0.420
SQ	→	CL	0.163	0.280	0.443
CS	→	CE	0.516	0.000	0.516
CS	→	CL	0.220	0.228	0.448
CE	→	CL	0.435	0.000	0.435

Table 4: Influence value between research variables
Source: Output SEM AMOS

Table 4 presents the influence values between the research variables. The arrows between constructs indicate direct effects, while indirect and total effects are also provided. The construct of Corporate Image directly affects Customer Satisfaction, Customer Engagement, and Customer Loyalty, with influence values of 0.276, 0.230, and 0.241, respectively. Additionally, indirect effects and total effects are observed for these relationships. Similarly, the construct Service Quality demonstrates direct effects on CS, CE, and CL, with influence values of 0.433, 0.196, and 0.163, respectively, along with corresponding indirect and total effects. Furthermore, there are direct, indirect, and total effects between CS, CE, and CL, illustrating the interconnectedness of these constructs within the study.

4.4. Hypothesis testing

There are nine research hypotheses, all supported by the research findings. After carrying out all the research processes, the authors can find answers to the research hypotheses. The table below shows the research hypothesis testing.

Constructs			Direct Effect	Indirect Effect	Supported (Yes/No)
CE	→	CL	Yes	No	Yes
CS	→	CL	Yes	Yes	Yes
CS	→	CE	Yes	No	Yes
SQ	→	CS	Yes	No	Yes
SQ	→	CE	Yes	Yes	Yes
SQ	→	CL	Yes	Yes	Yes
CI	→	CS	Yes	No	Yes
CI	→	CE	Yes	Yes	Yes
CI	→	CL	Yes	Yes	Yes

Table 5: Hypothesis testing
Source: Output SEM AMOS

Table 5 presents hypothesis testing results. The construct variables from Customer Engagement (CE) to Customer Loyalty (CL) show supported direct effects (Yes). Still, they do not have supported indirect effects (No), although overall, the hypotheses are supported (Yes). Hypotheses from Customer Satisfaction (CS) to CL demonstrate both direct and indirect effects (Yes), and overall, these hypotheses are also supported (Yes). Similarly, the relationships between CS and CE and SQ and CS show supported direct effects (Yes). Still, they lack supported indirect effects (No), although these hypotheses are supported overall (Yes). Furthermore, all hypotheses from SQ to CE and CL, as well as from CI to CS, CE, and CL, exhibit supported direct and indirect effects (Yes), and overall these hypotheses are also supported (Yes).

5. Discussion and implication

This study found that customer loyalty is directly influenced by customer engagement. Based on this finding, Islamic bank managers should prioritize the development of solid relationships with customers.^{119,120} This will strengthen the bond between the bank and customers through more profound and more sustainable interactions, helping to increase customer loyalty. Furthermore, Islamic bank managers should continuously strive to enhance the customer experience in transactions and interactions with the bank. It includes providing friendly, efficient, and *Shari'ah*-compliant services, thus increasing customer engagement and loyalty.^{121,122}

According to this study, customer satisfaction at Islamic banks affects loyalty. Based on this finding, the management of Islamic banks can develop strategies such as identifying the key drivers of customer satisfaction within Islamic banking, such as service quality, product offerings, convenience, or ethical considerations.¹²³ They can continuously innovate and enhance product offerings to meet Islamic banking customers' evolving needs and preferences. Furthermore, they should emphasize trust and transparency in all banking operations, creating an environment where customers feel confident and secure in their interactions with the bank.

The study found that customer satisfaction directly impacts customer engagement. Based on this finding, managers of Islamic banks can implement strategies such as enhancing customer satisfaction by improving service quality, product offerings, and overall customer experience to influence customer engagement positively.¹²⁴ Additionally, they can regularly gather and analyze customer feedback to understand their needs, preferences, and satisfaction levels, enabling targeted improvements to enhance engagement.¹²⁵ Furthermore, leveraging technology platforms and tools to facilitate communication, streamline processes, and provide convenient banking solutions can contribute to higher levels of customer engagement.¹²⁶

According to the findings, the quality of services Islamic banks provide impacts customer satisfaction. Based on these findings, the manager of an Islamic bank could implement several policies. Firstly, they should understand Islamic banking customers' unique needs and preferences and tailor services accordingly.¹²⁷ It may involve offering *Shari'ah*-compliant financial products and services that meet customers' ethical and religious requirements. Secondly, the manager should adopt a culture of continuous improvement within the organization by encouraging innovation and regularly reviewing processes to identify opportunities for enhancement.¹²⁸ Furthermore, it is crucial to emphasize transparency in all customer transactions,

ensuring they can access clear and accurate information about the bank's products, services, and fees.¹²⁹

The study results found that service quality positively and significantly affected customer engagement. Based on these findings, the manager of an Islamic bank should take several steps. Firstly, they should enhance the quality of services provided by the bank.¹³⁰ It may involve improving staff training, upgrading technological infrastructure, and refining operational processes to ensure efficient and effective service delivery. Secondly, they should focus on customer engagement by strengthening interactions between the bank and customers.¹³¹ It can be achieved by offering responsive services, facilitating customer comments, and creating satisfying customer experiences.

Furthermore, this research discovered that service quality influences customer loyalty. Based on this finding, the manager of an Islamic bank should prioritize actions to enhance service quality, recognizing its direct impact on customer loyalty. It may involve implementing measures to improve various aspects of service delivery, such as staff training, operational efficiency, and technological infrastructure.¹³² Additionally, the manager should focus on consistently meeting or exceeding customer expectations to foster trust and satisfaction, thereby increasing customer loyalty to the bank.¹³³

This study reveals that corporate image positively affects the customer satisfaction of Islamic banks. Based on this finding, the manager of an Islamic bank should take proactive steps to enhance the bank's corporate image.¹³⁴ It may involve implementing strategies to improve brand visibility, reputation management, and communication efforts to portray the bank positively to customers. Additionally, delivering high-quality services and maintaining transparency in all interactions can contribute to building a favourable corporate image.¹³⁵

This study found that corporate image positively and significantly influences customer engagement. Managers need to review the strategy for building the corporate image.¹³⁶ They must ensure that the corporate image reflects the values customers desire and aligns with *Shari'ah* principles. Based on these findings, bank managers need to enhance interaction with customers. It can be achieved through more responsive customer service, reward programs, or promotional activities to strengthen the corporate image.¹³⁷

This study also found that corporate image affects customer loyalty to Islamic banks. The manager should review the bank's corporate image, ensuring it aligns with the values and principles of Islamic banking.¹³⁸ Any inconsistencies should be addressed to bolster the bank's perception among customers. Recognizing that corporate image impacts customer loyalty, the manager should introduce or improve loyalty programs tailored to the preferences and needs of Islamic banking customers. These programs could encompass rewards, special offers, or personalized services to encourage repeat business.¹³⁹

6. Conclusion

This study examines the determinant factors affecting customer loyalty in Islamic banks. It was conducted by distributing questionnaires to 500 randomly selected respondents in West Sumatra, Indonesia, and employed SEM analysis. The findings reveal that service quality and corporate image strongly and positively influence customer satisfaction in Islamic banks. Additionally, the study indicates that quality of service and company image significantly and positively impact customer engagement. Furthermore, all determinant factors substantially and positively affect customer loyalty in Islamic banks. However, there are several limitations to this study. Firstly, it was conducted in Indonesia, where most of the population is Muslim. Secondly, the research was limited to one province, West Sumatra. Thirdly, the study did not explore all factors influencing customer satisfaction, engagement, and loyalty in Islamic banks.

The study enhances our understanding of customer loyalty in Islamic banks by identifying key determinants such as service quality and corporate image. It enriches theoretical frameworks in customer relationship management within Islamic banking by highlighting their significant influence on customer satisfaction, engagement, and loyalty. Additionally, it contributes to the literature by demonstrating how these factors impact customer behavior uniquely in Islamic financial institutions. Overall, the study advances theoretical knowledge on customer loyalty in Islamic banks, suggesting avenues for further research and refinement within existing frameworks. The findings highlight the importance of service quality and corporate image in fostering customer satisfaction and engagement within Islamic banks, emphasizing the need for high service standards and a positive brand image to enrich customer experiences. Moreover, the results indicate that these factors substantially drive customer loyalty in Islamic banks. This implies that initiatives aimed at enhancing service quality and bolstering the corporate image can increase customer retention and loyalty, which are crucial for the longevity and prosperity of Islamic banking institutions.

References

- ¹ Nasfi Nasfi, Yunimar Yunimar, and Adi Prawira, "The Role of Fintech in Sharia Rural Bank West Sumatra", *International Journal of Social and Management Studies* 3, no. 2 (2022): 13–19.
- ² Nasfi Nasfi, Yunimar Yunimar, and Adi Prawira, "The Role of Fintech in Sharia Rural Bank West Sumatra", *International Journal of Social and Management Studies* 3, no. 2 (2022): 13–19.
- ³ Tyas Ayuningrum, and Mochlasin Mochlasin, "The Influence of Brand Awareness, Customer Value and Trust toward Loyalty Customers with Satisfaction as Intervening." *JIEM: Journal of Islamic Entrepreneurship and Management* 1, no. 2 (2021): 23–42.
- ⁴ Hesti Dwi Lestari and Imanda Firmantyas Putri Pertiwi, "The Effect of Corporate Social Responsibility (CSR), Relationship Marketing and Shariah Compliance on Customer Loyalty with Customer Emotional Response as Intervening", *Social Science Studies* 2, no. 1 (2022): 001–014.
- ⁵ Ni Luh Putu Indiani, I. Made Pulawan, and Ni Made Santini, "Which Consumer Groups Are More Loyal? Evidence in Indonesian Banking Industry", *Montenegrin Journal of Economics* 18, no. 1 (2022): 47–60.
- ⁶ Bayu Arie Fianto et al., "Customer Loyalty to Islamic Banks: Evidence from Indonesia." *Cogent Business & Management* 7, no. 1 (2020): 1859849.
- ⁷ C. H. EzuRizzy and D. G. Ademe, "E-Service Quality and Customer Engagement of Online Shops in Bayelsa State, Nigeria", *GPH - International Journal of Business Management (IJBM)* 5, no. 1 (2022): 76–87.
- ⁸ Darwin Dhasan, and Mayuree Aryupong. "Effects of Product Quality, Service Quality and Price Fairness on Customer Engagement and Customer Loyalty." *ABAC Journal* 39, no. 2 (2019): 82–102.
- ⁹ Siti Fatimah, "Growing Customer Loyalty through Excellent Service and Business Ethics", *BJRM (Bongaya Journal of Research in Management)* 4, no. 2 (2021): 1–6.
- ¹⁰ Precious Chikezie Ezeh and Anayo D. Nkamnebe, "Determinants of Islamic Banking Adoption among Non-Muslim Customers in a Muslim Zone", *Journal of Islamic Accounting and Business Research* 13, no. 4 (2022): 666–83.
- ¹¹ Hanieh Mohammadzadeh Taheri et al., "Designing a Model for the Acceptance of Innovation-Based Health Services with a Mixed-Method Exploratory Approach", *New Marketing Research Journal* 10, no. 4 (2021): 81–89.
- ¹² Jamshed Haidery, Sayed Wali Shah Mandozai, and Hafizullahmeen Amin. "Investigating Structural Relationship between Service Quality, Satisfaction and Loyalty in Banking Sector of Afghanistan." *Economics and Business Quarterly Reviews* 4, no. 2 (2021): 151–63.
- ¹³ Tyas Ayuningrum, and Mochlasin Mochlasin. "The Influence of Brand Awareness, Customer Value and Trust toward Loyalty Customers with Satisfaction as Intervening." *JIEM: Journal of Islamic Entrepreneurship and Management* 1, no. 2 (2021): 23–42.
- ¹⁴ Özgür Kökalan and Ahmet Bingöl, "Service Quality of Conventional and Islamic Banks in Turkey", *Trziste* 33, no. 1 (2021): 59.

-
- ¹⁵ Mohammad Niaz Morshed, "Service Quality Management Practices for Customer Satisfaction in Islamic Banks of Bangladesh", *International Journal of Innovative Research and Publications* 1, no. 3 (2021): 47–59.
- ¹⁶ Moh Nasuka, Tony Wijaya, and Anas Hidayat, "The Role of Islamic Marketing Ethics for Customer Loyalty in Islamic Banking through Customer Satisfaction", *Economic Annals-XXI* 187, no. 1/2 (2021): 189–96.
- ¹⁷ Bayu Arie Fianto et al., "Customer Loyalty to Islamic Banks: Evidence from Indonesia." *Cogent Business & Management* 7, no. 1 (2020): 1859849.
- ¹⁸ Lovemore Chikazhe, Charles Makanyeza, and Blessing Chigunhah "Understanding Mediators and Moderators of the Effect of Customer Satisfaction on Loyalty." *Cogent Business & Management* 8, no. 1 (2021): 1922127.
- ¹⁹ Nicholas Igbudu, Zanete Garanti, and Temitope Popoola. "Enhancing Bank Loyalty through Sustainable Banking Practices: The Mediating Effect of Corporate Image." *Sustainability* 10, no. 11 (2018): 4050.
- ²⁰ Lovemore Chikazhe, Charles Makanyeza, and Blessing Chigunhah, "Understanding Mediators and Moderators of the Effect of Customer Satisfaction on Loyalty," *Cogent Business & Management* 8, no. 1 (2021): 1922127.
- ²¹ Moh Nasuka, Tony Wijaya, and Anas Hidayat. "The Role of Islamic Marketing Ethics for Customer Loyalty in Islamic Banking through Customer Satisfaction." *Economic Annals-XXI* 187, no. 1/2 (2021): 189–96.
- ²² Jamshed Haidery, Sayed Wali Shah Mandozai, and Hafizullahmeen Amin. "Investigating Structural Relationship between Service Quality, Satisfaction and Loyalty in Banking Sector of Afghanistan." *Economics and Business Quarterly Reviews* 4, no. 2 (2021): 151–63.
- ²³ Bayu Arie Fianto et al., "Customer Loyalty to Islamic Banks: Evidence from Indonesia." *Cogent Business & Management* 7, no. 1 (2020): 1859849.
- ²⁴ Jamshed Haidery, Sayed Wali Shah Mandozai, and Hafizullahmeen Amin. "Investigating Structural Relationship between Service Quality, Satisfaction and Loyalty in Banking Sector of Afghanistan." *Economics and Business Quarterly Reviews* 4, no. 2 (2021): 151–63.
- ²⁵ Mohammad Niaz Morshed. "Service Quality Management Practices for Customer Satisfaction in Islamic Banks of Bangladesh." *International Journal of Innovative Research and Publications* 1, no. 3 (2021): 47–59.
- ²⁶ Bodo Möslein-Tröppner, Michael Stros, and David Říha, "Customer Loyalty-Related Marketing Measures in Fashion Markets", *Central European Business Review* 9, no. 1 (2020): 43–55.
- ²⁷ Nicholas Igbudu, Zanete Garanti, and Temitope Popoola. "Enhancing Bank Loyalty through Sustainable Banking Practices: The Mediating Effect of Corporate Image." *Sustainability* 10, no. 11 (2018): 4050.
- ²⁸ Fatimah, "Growing Customer Loyalty through Excellent Service and Business Ethics".
- ²⁹ Jamshed Haidery, Sayed Wali Shah Mandozai, and Hafizullahmeen Amin. "Investigating Structural Relationship between Service Quality, Satisfaction and Loyalty in Banking Sector of Afghanistan." *Economics and Business Quarterly Reviews* 4, no. 2 (2021): 151–63.

-
- ³⁰ Bayu Arie Fianto et al., "Customer Loyalty to Islamic Banks: Evidence from Indonesia." *Cogent Business & Management* 7, no. 1 (2020): 1859849.
- ³¹ Aminah Osman, "Customers' Satisfaction Level of Islamic Banking Service in Kelantan, Malaysia", *Turcomat* 12, no. 3 (2021): 489–96.
- ³² Bayu Arie Fianto et al., "Customer Loyalty to Islamic Banks: Evidence from Indonesia." *Cogent Business & Management* 7, no. 1 (2020): 1859849.
- ³³ C. H. EzuRizzy and D. G. Ademe, "E-Service Quality and Customer Engagement of Online Shops in Bayelsa State, Nigeria," *GPH - International Journal of Business Management (IJBM)* 5, no. 1 (2022): 76–87.
- ³⁴ Bayu Arie Fianto et al., "Customer Loyalty to Islamic Banks: Evidence from Indonesia." *Cogent Business & Management* 7, no. 1 (2020): 1859849.
- ³⁵ Darwin Dhasan, and Mayuree Aryupong. "Effects of Product Quality, Service Quality and Price Fairness on Customer Engagement and Customer Loyalty." *ABAC Journal* 39, no. 2 (2019): 82–102.
- ³⁶ C. H. EzuRizzy and D. G. Ademe, "E-Service Quality and Customer Engagement of Online Shops in Bayelsa State, Nigeria," *GPH - International Journal of Business Management (IJBM)* 5, no. 1 (2022): 76–87.
- ³⁷ C. C. Williams and N. Mackay. "Customer Engagement in Retail Banks: Scale Development and Validation," *The Retail and Marketing Review* 16, no. 1 (2020): 40–52.
- ³⁸ Bayu Arie Fianto et al., "Customer Loyalty to Islamic Banks: Evidence from Indonesia." *Cogent Business & Management* 7, no. 1 (2020): 1859849.
- ³⁹ Mohammad Niaz Morshed. "Service Quality Management Practices for Customer Satisfaction in Islamic Banks of Bangladesh." *International Journal of Innovative Research and Publications* 1, no. 3 (2021): 47–59.
- ⁴⁰ C. C. Williams and N. Mackay. "Customer Engagement in Retail Banks: Scale Development and Validation," *The Retail and Marketing Review* 16, no. 1 (2020): 40–52.
- ⁴¹ Darwin Dhasan, and Mayuree Aryupong. "Effects of Product Quality, Service Quality and Price Fairness on Customer Engagement and Customer Loyalty." *ABAC Journal* 39, no. 2 (2019): 82–102.
- ⁴² Bayu Arie Fianto et al., "Customer Loyalty to Islamic Banks: Evidence from Indonesia." *Cogent Business & Management* 7, no. 1 (2020): 1859849.
- ⁴³ Nga Thi VO, Miloslava Chovancová, and Ho Thanh Tri, "The Impact of E-Service Quality on the Customer Satisfaction and Consumer Engagement Behaviors toward Luxury Hotels", *Journal of Quality Assurance in Hospitality & Tourism* 21, no. 5 (2019): 499–523.
- ⁴⁴ Bayu Arie Fianto et al., "Customer Loyalty to Islamic Banks: Evidence from Indonesia." *Cogent Business & Management* 7, no. 1 (2020): 1859849.
- ⁴⁵ Darwin Dhasan, and Mayuree Aryupong. "Effects of Product Quality, Service Quality and Price Fairness on Customer Engagement and Customer Loyalty." *ABAC Journal* 39, no. 2 (2019): 82–102.

-
- ⁴⁶ C. C. Williams and N. Mackay. "Customer Engagement in Retail Banks: Scale Development and Validation," *The Retail and Marketing Review* 16, no. 1 (2020): 40–52.
- ⁴⁷ Rusdianto Rusdianto and Mochammad Jasin, "Dynamic Behavior of Islamic Banking Customer Loyalty in Jakarta", *IQTISHADIA* 14, no. 2 (2021): 179–96.
- ⁴⁸ Nicholas Igbudu, Zanete Garanti, and Temitope Popoola. "Enhancing Bank Loyalty through Sustainable Banking Practices: The Mediating Effect of Corporate Image." *Sustainability* 10, no. 11 (2018): 4050.
- ⁴⁹ Fatimah, "Growing Customer Loyalty through Excellent Service and Business Ethics".
- ⁵⁰ Mohammad Niaz Morshed. "Service Quality Management Practices for Customer Satisfaction in Islamic Banks of Bangladesh." *International Journal of Innovative Research and Publications* 1, no. 3 (2021): 47–59.
- ⁵¹ Rizal Ula Ananta Fauzi, Dian Cita Ningtiyas Ari Kadi, and Arman Hj Ahmad, "The Role of Trust as Mediator in the Effect of Religiosity and Bank Image towards Consumers' Intention: An Empirical Case Study of Bank Muamalat, Indonesia." *Asia Pacific Journal of Social Science Research* 6, no. 1 (2021): 22.
- ⁵² Mohammad Niaz Morshed. "Service Quality Management Practices for Customer Satisfaction in Islamic Banks of Bangladesh." *International Journal of Innovative Research and Publications* 1, no. 3 (2021): 47–59.
- ⁵³ Fauzi, Kadi, and Ahmad, "The Role of Trust as Mediator in the Effect of Religiosity and Bank Image towards Consumers' Intention".
- ⁵⁴ Aminah Osman, "Customers' Satisfaction Level of Islamic Banking Service in Kelantan, Malaysia." *TURCOMAT* 12, no. 3 (2021): 489–96.
- ⁵⁵ Mohammad Niaz Morshed. "Service Quality Management Practices for Customer Satisfaction in Islamic Banks of Bangladesh." *International Journal of Innovative Research and Publications* 1, no. 3 (2021): 47–59.
- ⁵⁶ Mohamed Eid Kilase Ajoud and Tahar Ammar Jouili, "Healthcare Service Quality in Government Hospitals: Evaluating Patients' Satisfaction", *Calitatea* 22, no. 182 (2021): 106–9.
- ⁵⁷ Pierre Mostert, Eksteen Theron, and Jack Kruger, "A Disaggregated Approach to Establishing the Antecedents and Outcome of Relationship Quality in the South African Banking Industry", *International Journal of Services, Economics and Management* 12, no. 4 (2021): 317–37.
- ⁵⁸ Mokgadi Cleopatra Taoana, Emmanuel Silva Quaye, and Russell Abratt, "Antecedents of Brand Loyalty in South African Retail Banking", *Journal of Financial Services Marketing* 10, no. 4 (2021): 1–16.
- ⁵⁹ Boon Liat Cheng et al., "Tourist Satisfaction in the Malaysia Tourism Industry: Relationship between Service Innovation and Destination Image", *Jurnal Pengurusan* 60 (2020): 1–18.
- ⁶⁰ Kökalan and Bingöl, "Service Quality of Conventional and Islamic Banks in Turkey".
- ⁶¹ Khawaja Fawad Latif, "Recipes for Customer Loyalty: A Cross-Country Study of the Hotel Industry", *International Journal of Contemporary Hospitality Management* 33, no. 5 (2021): 1892–1916.
- ⁶² Ilisa Fajriyati et al., "Attributes Influencing Overall Tourist Satisfaction and Its Consequences for Muslim-Majority Destination", *SAGE Open* 12, no. 1 (2022): 1–14.
- ⁶³ Cheng et al., "Tourist Satisfaction in the Malaysia Tourism Industry".

-
- ⁶⁴ Nurdin Sobari, Andyan Kurniati, and Hardius Usman, "The Influence of Islamic Attributes and Religious Commitments toward Halal Wellness Services Customer Satisfaction and Loyalty", *Journal of Islamic Marketing* 13, no. 1 (2019): 177–97.
- ⁶⁵ Ezeh and Nkamnebe, "Determinants of Islamic Banking Adoption among Non-Muslim Customers in a Muslim Zone".
- ⁶⁶ C. H. EzuRizzy and D. G. Ademe, "E-Service Quality and Customer Engagement of Online Shops in Bayelsa State, Nigeria," *GPH - International Journal of Business Management (IJBM)* 5, no. 1 (2022): 76–87.
- ⁶⁷ Nga Thi VO, Miloslava Chovancová, and Ho Thanh Tri. "The Impact of E-Service Quality on the Customer Satisfaction and Consumer Engagement Behaviors toward Luxury Hotels." *Journal of Quality Assurance in Hospitality & Tourism* 21, no. 5 (2019): 499–523.
- ⁶⁸ C. H. EzuRizzy and D. G. Ademe, "E-Service Quality and Customer Engagement of Online Shops in Bayelsa State, Nigeria," *GPH - International Journal of Business Management (IJBM)* 5, no. 1 (2022): 76–87.
- ⁶⁹ Bodo Möslein-Tröppner, Michael Stros, and David Říha, "Customer Loyalty-Related Marketing Measures in Fashion Markets," *Central European Business Review* 9, no. 1 (2020): 43.
- ⁷⁰ Mohammad Niaz Morshed. "Service Quality Management Practices for Customer Satisfaction in Islamic Banks of Bangladesh." *International Journal of Innovative Research and Publications* 1, no. 3 (2021): 47–59.
- ⁷¹ Daniel Ferreira Polónia, Ana Alexandra Da Costa Dias, and Rui Diogo Soares Dos Santos, "Patient Satisfaction in Hospital Emergency Services: A Perspective from Portugal", *International Journal of Productivity and Quality Management* 31, no. 3 (2020): 349–68.
- ⁷² Ajoud and Jouili, 'Healthcare Service Quality in Government Hospitals'.
- ⁷³ Aminah Osman, "Customers' Satisfaction Level of Islamic Banking Service in Kelantan, Malaysia." *TURCOMAT* 12, no. 3 (2021): 489–96.
- ⁷⁴ Mohammad Niaz Morshed. "Service Quality Management Practices for Customer Satisfaction in Islamic Banks of Bangladesh." *International Journal of Innovative Research and Publications* 1, no. 3 (2021): 47–59.
- ⁷⁵ Darwin Dhasan, and Mayuree Aryupong. "Effects of Product Quality, Service Quality and Price Fairness on Customer Engagement and Customer Loyalty." *ABAC Journal* 39, no. 2 (2019): 82–102.
- ⁷⁶ C. C. Williams and N. Mackay. "Customer Engagement in Retail Banks: Scale Development and Validation," *The Retail and Marketing Review* 16, no. 1 (2020): 40–52.
- ⁷⁷ C. H. EzuRizzy and D. G. Ademe, "E-Service Quality and Customer Engagement of Online Shops in Bayelsa State, Nigeria," *GPH - International Journal of Business Management (IJBM)* 5, no. 1 (2022): 76–87.
- ⁷⁸ Möslein-Tröppner, Stros, and Říha, "Customer Loyalty-Related Marketing Measures in Fashion Markets".
- ⁷⁹ Kökalan and Bingöl, "Service Quality of Conventional and Islamic Banks in Turkey".
- ⁸⁰ Bayu Arie Fianto et al., "Customer Loyalty to Islamic Banks: Evidence from Indonesia." *Cogent Business & Management* 7, no. 1 (2020): 1859849.

-
- ⁸¹ Mohammad Niaz Morshed. "Service Quality Management Practices for Customer Satisfaction in Islamic Banks of Bangladesh." *International Journal of Innovative Research and Publications* 1, no. 3 (2021): 47–59.
- ⁸² Moh Nasuka, Tony Wijaya, and Anas Hidayat. "The Role of Islamic Marketing Ethics for Customer Loyalty in Islamic Banking through Customer Satisfaction." *Economic Annals-XXI* 187, no. 1/2 (2021): 189–96.
- ⁸³ Siti Ngayesah Ab Hamid, Wan Jamaliah Wan Jusoh, and Suharni Maulan, "The Influence of Spiritual Brand Attributes towards the Corporate Brand Image of Islamic Banking Institutions in Malaysia", *Jurnal Pengurusan* 61 (2021): 31–41.
- ⁸⁴ Nicholas Igbudu, Zanete Garanti, and Temitope Popoola. "Enhancing Bank Loyalty through Sustainable Banking Practices: The Mediating Effect of Corporate Image." *Sustainability* 10, no. 11 (2018): 4050.
- ⁸⁵ Lovemore Chikazhe, Charles Makanyeza, and Blessing Chigunhah "Understanding Mediators and Moderators of the Effect of Customer Satisfaction on Loyalty." *Cogent Business & Management* 8, no. 1 (2021): 1922127.
- ⁸⁶ Fatimah, "Growing Customer Loyalty through Excellent Service and Business Ethics".
- ⁸⁷ Hamid, Jusoh, and Maulan, "The Influence of Spiritual Brand Attributes towards the Corporate Brand Image of Islamic Banking Institutions in Malaysia".
- ⁸⁸ Fatimah, "Growing Customer Loyalty through Excellent Service and Business Ethics".
- ⁸⁹ C. C. Williams and N. Mackay. "Customer Engagement in Retail Banks: Scale Development and Validation," *The Retail and Marketing Review* 16, no. 1 (2020): 40–52.
- ⁹⁰ Bayu Arie Fianto et al., "Customer Loyalty to Islamic Banks: Evidence from Indonesia." *Cogent Business & Management* 7, no. 1 (2020): 1859849.
- ⁹¹ Bayu Arie Fianto et al., "Customer Loyalty to Islamic Banks: Evidence from Indonesia." *Cogent Business & Management* 7, no. 1 (2020): 1859849.
- ⁹² Nga Thi VO, Miloslava Chovancová, and Ho Thanh Tri. "The Impact of E-Service Quality on the Customer Satisfaction and Consumer Engagement Behaviors toward Luxury Hotels." *Journal of Quality Assurance in Hospitality & Tourism* 21, no. 5 (2019): 499–523.
- ⁹³ Moh Nasuka, Tony Wijaya, and Anas Hidayat. "The Role of Islamic Marketing Ethics for Customer Loyalty in Islamic Banking through Customer Satisfaction." *Economic Annals-XXI* 187, no. 1/2 (2021): 189–96.
- ⁹⁴ Taoana, Quaye, and Abratt, 'Antecedents of Brand Loyalty in South African Retail Banking'.
- ⁹⁵ Bayu Arie Fianto et al., "Customer Loyalty to Islamic Banks: Evidence from Indonesia." *Cogent Business & Management* 7, no. 1 (2020): 1859849.
- ⁹⁶ Joseph F Hair, Barry J Babin, and Rolph E Anderson, *Multivariate Data Analysis* (New Jersey: Prentice-Hall, 2014).
- ⁹⁷ Mostert, Theron, and Kruger, 'A Disaggregated Approach to Establishing the Antecedents and Outcome of Relationship Quality in the South African Banking Industry'.

-
- ⁹⁸ Moh Nasuka, Tony Wijaya, and Anas Hidayat. "The Role of Islamic Marketing Ethics for Customer Loyalty in Islamic Banking through Customer Satisfaction." *Economic Annals-XXI* 187, no. 1/2 (2021): 189–96.
- ⁹⁹ Fajriyati et al., "Attributes Influencing Overall Tourist Satisfaction and Its Consequences for Muslim-Majority Destination".
- ¹⁰⁰ Sobari, Kurniati, and Usman, "The Influence of Islamic Attributes and Religious Commitments toward Halal Wellness Services Customer Satisfaction and Loyalty".
- ¹⁰¹ Bayu Arie Fianto et al., "Customer Loyalty to Islamic Banks: Evidence from Indonesia", ed. Pantea Foroudi, *Cogent Business & Management* 7, no. 1 (1 January 2020): 1859849, <https://doi.org/10.1080/23311975.2020.1859849>.
- ¹⁰² Nga Thi VO, Miloslava Chovancová, and Ho Thanh Tri. "The Impact of E-Service Quality on the Customer Satisfaction and Consumer Engagement Behaviors toward Luxury Hotels." *Journal of Quality Assurance in Hospitality & Tourism* 21, no. 5 (2019): 499–523.
- ¹⁰³ Lovemore Chikazhe, Charles Makanyeza, and Blessing Chigunhah "Understanding Mediators and Moderators of the Effect of Customer Satisfaction on Loyalty." *Cogent Business & Management* 8, no. 1 (2021): 1922127.
- ¹⁰⁴ Indiani, Pulawan, and Santini, "Which Consumer Groups Are More Loyal?"
- ¹⁰⁵ Hamid, Jusoh, and Maulan, "The Influence of Spiritual Brand Attributes towards the Corporate Brand Image of Islamic Banking Institutions in Malaysia".
- ¹⁰⁶ Nicholas Igbudu, Zanete Garanti, and Temitope Popoola, "Enhancing Bank Loyalty through Sustainable Banking Practices: The Mediating Effect of Corporate Image", *Sustainability* 10, no. 11 (2018): 4050, <https://doi.org/10.3390/su10114050>.
- ¹⁰⁷ Hair, Babin, and Anderson, *Multivariate Data Analysis*.
- ¹⁰⁸ Hair, Babin, and Anderson.
- ¹⁰⁹ Zahra, Fatima, and Muhammad Usman. "Religious Advertisements of Islamic Banks: Aesthetic Satisfaction and Psychology of Colors." *Karachi Islamicus* 2, no. 2 (2022): 46-56.
- ¹¹⁰ Krisna Nugraha et al., "Factors Influencing Bank Customers' Orientations toward Islamic Banks: Indonesian Banking Perspective," *Sustainability* 14, no. 19 (2022): 12506, <https://doi.org/10.3390/su141912506>.
- ¹¹¹ Mahmoud Yasin et al., "The Role of Customer Online Brand Experience in Customers' Intention to Forward Online Company-Generated Content: The Case of the Islamic Online Banking Sector in Palestine", *Journal of Retailing and Consumer Services* 52 (2020): 101902, <https://doi.org/10.1016/j.jretconser.2019.101902>.
- ¹¹² Rizaldi Yusfiarto et al., "Examining Islamic Capital Market Adoption from a Socio-Psychological Perspective and Islamic Financial Literacy", *Journal of Islamic Accounting and Business Research* 14, no. 4 (2023): 574–94, <https://doi.org/10.1108/JIABR-02-2022-0037>.
- ¹¹³ Muhamad Nadrattuzaman Hosen, Fitriyani Lathifah, and Ferry Jie, "Perception and Expectation of Customers in Islamic Bank Perspective", *Journal of Islamic Marketing* 12, no. 1 (2021): 1–19, <https://doi.org/10.1108/JIMA-12-2018-0235>.

-
- ¹¹⁴ Aamir Abbas et al., “The Role of Islamic Marketing Ethics towards Customer Satisfaction”, *Journal of Islamic Marketing* 11, no. 4 (2019): 1001–18, <https://doi.org/10.1108/JIMA-11-2017-0123>.
- ¹¹⁵ Tika Kartika, Achmad Firdaus, and Mukhamad Najib, “Contrasting the Drivers of Customer Loyalty; Financing and Depositor Customer, Single and Dual Customer, in Indonesian Islamic Bank”, *Journal of Islamic Marketing* 11, no. 4 (2019): 933–59, <https://doi.org/10.1108/JIMA-04-2017-0040>.
- ¹¹⁶ Buerhan Saiti, Abubakar Aliyu Ardo, and Ibrahim Guran Yumusak, “Why Non-Muslims Subscribe to Islamic Banking?,” *Qualitative Research in Financial Markets* 14, no. 2 (2022): 247–69, <https://doi.org/10.1108/QRFM-01-2018-0005>.
- ¹¹⁷ Nur Asnawi, Badri Munir Sukoco, and Muhammad Asnan Fanani, “The Role of Service Quality within Indonesian Customers Satisfaction and Loyalty and Its Impact on Islamic Banks”, *Journal of Islamic Marketing* 11, no. 1 (2019): 192–212, <https://doi.org/10.1108/JIMA-03-2017-0033>.
- ¹¹⁸ Ilham Hassan F. Mansour, “Customers’ Perceptions of Selection Criteria Used by Islamic Bank Customers in Sudan: The Importance of Shariah Compliance,” *SSRN Electronic Journal*, (2019), <https://doi.org/10.2139/ssrn.3480464>.
- ¹¹⁹ Yudi Ahmad Faisal et al., “Examining the Purchase Intentions of Indonesian Investors for Green Sukuk,” *Sustainability* 15, no. 9 (2023): 7430, <https://doi.org/10.3390/su15097430>.
- ¹²⁰ C. C. Williams and N. Mackay. “Customer Engagement in Retail Banks: Scale Development and Validation,” *The Retail and Marketing Review* 16, no. 1 (2020): 40–52.
- ¹²¹ Roni Andespa, Yulia Hendri Yeni, Yudi Fernando, and Dessy Kurnia Sari, “A Systematic Review of Customer Sharia Compliance Behaviour in Islamic Banks: Determinants and Behavioural Intention,” *Journal of Islamic Marketing*, (2023), <https://doi.org/10.1108/JIMA-06-2023-0181>.
- ¹²² Darwin Dhasan, and Mayuree Aryupong. “Effects of Product Quality, Service Quality and Price Fairness on Customer Engagement and Customer Loyalty.” *ABAC Journal* 39, no. 2 (2019): 82–102.
- ¹²³ Ezech and Nkamnebe, ‘Determinants of Islamic Banking Adoption among Non-Muslim Customers in a Muslim Zone’.
- ¹²⁴ Nga Thi VO, Miloslava Chovancová, and Ho Thanh Tri. “The Impact of E-Service Quality on the Customer Satisfaction and Consumer Engagement Behaviors toward Luxury Hotels.” *Journal of Quality Assurance in Hospitality & Tourism* 21, no. 5 (2019): 499–523.
- ¹²⁵ C. H. EzuRizzy and D. G. Ademe, “E-Service Quality and Customer Engagement of Online Shops in Bayelsa State, Nigeria,” *GPH - International Journal of Business Management (IJBM)* 5, no. 1 (2022): 76–87.
- ¹²⁶ Rizky Yudaruddin, “Financial Technology and Performance in Islamic and Conventional Banks”, *Journal of Islamic Accounting and Business Research* 14, no. 1 (2 January 2023): 100–116, <https://doi.org/10.1108/JIABR-03-2022-0070>.
- ¹²⁷ Suzanna ElMassah and Heba Abou-El-Sood, “Selection of Islamic Banking in a Multicultural Context: The Role of Gender and Religion”, *Journal of Islamic Marketing* 13, no. 11 (2022): 2347–77, <https://doi.org/10.1108/JIMA-05-2020-0160>.

-
- ¹²⁸ N.A. Nurdin and Khaeruddin Yusuf, “Knowledge Management Lifecycle in Islamic Bank: The Case of *Syariah* Banks in Indonesia”, *International Journal of Knowledge Management Studies* 11, no. 1 (2020): 59, <https://doi.org/10.1504/IJKMS.2020.105073>.
- ¹²⁹ Tria Yulia Rahmawati, Miranti Kartika Dewi, and Ilham Reza Ferdian, “Instagram: Its Roles in Management of Islamic Banks”, *Journal of Islamic Marketing* 11, no. 4 (18 July 2019): 841–61, <https://doi.org/10.1108/JIMA-11-2018-0213>.
- ¹³⁰ Selim Ahmed et al., “The Impact of Islamic Shariah Compliance on Customer Satisfaction in Islamic Banking Services: Mediating Role of Service Quality”, *Journal of Islamic Marketing* 13, no. 9 (2022): 1829–42, <https://doi.org/10.1108/JIMA-11-2020-0346>.
- ¹³¹ Dipa Mulia, Hardius Usman, and Novia Budi Parwanto, “The Role of Customer Intimacy in Increasing Islamic Bank Customer Loyalty in Using E-Banking and m-Banking”, *Journal of Islamic Marketing* 12, no. 6 (2021): 1097–1123, <https://doi.org/10.1108/JIMA-09-2019-0190>.
- ¹³² Ghazi Zouari and Marwa Abdelhedi, “Customer Satisfaction in the Digital Era: Evidence from Islamic Banking”, *Journal of Innovation and Entrepreneurship* 10, no. 1 (2021): 9, <https://doi.org/10.1186/s13731-021-00151-x>.
- ¹³³ Ety Saraswati, “Market Orientation, Service Quality on Customer Satisfaction and Loyalty: Study on Sharia Banking in Indonesia”, *Golden Ratio of Marketing and Applied Psychology of Business* 2, no. 1 (2021): 26–41, <https://doi.org/10.52970/grmapb.v2i1.157>.
- ¹³⁴ Muhammad Tahir Jan and Ali Shafiq, “Islamic Banks’ Brand Personality and Customer Satisfaction: An Empirical Investigation through SEM”, *Journal of Islamic Accounting and Business Research* 12, no. 4 (2021): 488–508, <https://doi.org/10.1108/JIABR-05-2020-0149>.
- ¹³⁵ Siti Ngayesah Hamid, Suharni Maulan, and Wan Jamaliah Wan Jusoh, “Brand Attributes, Corporate Brand Image and Customer Loyalty of Islamic Banks in Malaysia”, *Journal of Islamic Marketing* 14, no. 10 (2023): 2404–28, <https://doi.org/10.1108/JIMA-09-2021-0309>.
- ¹³⁶ Muhammad Adli Musa et al., “Islamic Business Ethics and Practices of Islamic Banks: Perceptions of Islamic Bank Employees in Gulf Cooperation Countries and Malaysia”, *Journal of Islamic Accounting and Business Research* 11, no. 5 (2020): 1009–31, <https://doi.org/10.1108/JIABR-07-2016-0080>.
- ¹³⁷ Hosen, Lathifah, and Jie, “Perception and Expectation of Customers in Islamic Bank Perspective”.
- ¹³⁸ Muhammad Bilal Zafar and Ahmad Azam Sulaiman, “Measuring Corporate Social Responsibility in Islamic Banking: What Matters?”, *International Journal of Islamic and Middle Eastern Finance and Management* 13, no. 3 (2020): 357–88, <https://doi.org/10.1108/IMEFM-05-2019-0227>.
- ¹³⁹ Muhammad Muflih, “The Link between Corporate Social Responsibility and Customer Loyalty: Empirical Evidence from the Islamic Banking Industry”, *Journal of Retailing and Consumer Services* 61 (2021): 102558, <https://doi.org/10.1016/j.jretconser.2021.102558>.