

Evaluation of Moisture Content in Paper-oil of Aged Power Transformer Using RVM

C.K.Dwivedi

*Disha Institute of Management and Technology,
Raipur (C.G.), INDIA
ckant.dwivedi@gmail.com*

M.B.Diagavane

*S.D.College of Engineering, Wardha
Nagpur (Maharashtra), INDIA.
mdai@rediffmail.com*

Abstract

The many diagnostic tools (like Conventional oil test, DGA, DLA and RVM) are available.. From the test results, it is observed that the transformer which has very good result from these techniques and even minimum moisture content in the winding may / will have very poor mechanical integrity. Winding cellulose paper may be aged to such an extent (assessed from DP) that may sudden force or transient may result in failure. DP cannot be conducted regularly to ascertain mechanical integrity of the winding paper.

Furan analysis is a substitute for DP. But most of time, Furans are not detected and there is no universal correlation available for DP and Furan.. Both, the moisture content and ageing of paper influences furan. Frequency response analysis gives the information regarding the movement of winding but does not give much, information above mechanical integrity of winding which is essential for transformer reliability.

In this paper, an approach has been made to compare the moisture content in the winding from RVM and estimated from oil ppm (using *Norris diagram*) and estimated from winding DLA (based on *Gussenbaner’s relationship*)

Key words - RVM, Polarization and Depolarization, DP.

1.0 Introduction:

Transformer is the heart of generation, transmission and distribution of electrical power. It represents a high capital investment in transmission substation, at the same time is of great importance to determine the loading capability of the network where the same arc is installed with appropriate maintenance, including insulation reconditioning in proper time, the life of transformer can be extended up to 50 years. By renovating the insulation status, mechanical integrity with the help of modern diagnostic tool, it is possible to predict earlier and doing so the quality and quantity investment can be saved. Diagnostic systems have been listed under three categories as portable/ periodic, continuous online and specialist support [1]. There are many online (for load operating conditions diagnostic tools like gas and moisture in oil are available these days [5]. The DGA is the key technique however sweep frequency analysis technique only sys about the movement of the windings and laminations from its original position, and does not test moisture content in winding paper insulation and its ageing. However, RVN technique is capable to estimate above cited, but

does not distinguish between moisture contents and degradation of winding paper. But another technique is correlating between charging current with paper ageing. This is a possibility that charging current may also correlate with insulation resistance (IR) as we found RVM following polarization index (PI).

The fundamental object of life management of aged transformer can be defined simply as “**To get the most out of an asset**” by insuring that the actions are carried out to provide the longest possible service life is the most appropriate. Experiences have shown that transformer oil contains about 70% of diagnostic in formations. The traditional diagnostic of oil program utilizes only some of diagnostic parameters. On the other hand, oil plays a critical role in life extension program. As a vital part of transformer –body, oil can be a killer of insulation system or may be very good friend. A major failure of transformer, caused by the breakdown of its insulation. System can generate great repair works and financial losses due to the outage of transmission process.

Therefore, the utilities are very interested to evaluate the condition of transformer insulation. The diagnostic parameters should represent the state of ageing of insulating components (Board and oil) and they should also show incipient failures which can lead to damage of transformer. Table -1shows the typical failure distribution of High Voltage transformer.

Table-1 (Failure of distribution of power transformer) [1, 5]

Serial No.	Components	% of Failure
1	Windings	24
2	Core	20
3	Switching device	14
4	Bushing	23
5	Tank	10
6	Cooling System	4
7	Safety device	1
8	Others	4

Table-1 reveals that the highest Risk for failure one winding and the bushing of transformer because in these regions the highest electrical field occurs during operations. Prior to commissioning

of transformer reversal tests and performed, these tests can be classified in (1) Routine test (ii) Type Tests (iii) Special tests, Routine Tests – Resistance measurements, determination of voltage ratio loss measurement and also acceptance Tests like P D or voltage with stand test (AC& Impulse voltage) before delivering the transformer to Uses.

Type Tests – Measurements are performed for each transformer design. These tests are necessary to show that design fulfills defined criteria for instance a temperature rise tests.

Special Tests—these are the tests which were agreed between manufacturer and users, an example is sound level test.

2.0 Factors affecting the life of Transformer [2].

The life of transformer may be introduced as the change of it's condition with time under impact of thermal, electric, electromagnetic,, electrodynamic and ageing process like moisture contents.

Fig.-1 shows a model of changes of transformer condition in course of its life cycle, and gives a rough idea about risk assessment program.

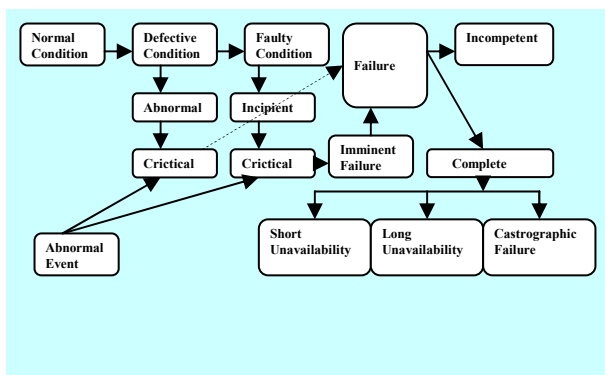

Fig.1. A model of changes of transformer condition

The term defective and faulty are not the same .Both the terms are 180° out of phase, defective is an abnormal condition attributed to reversible processes like insulation / oil contamination, clamping, relaxation of laminations, etc. When the materials have not yet being destroyed physically and could be restored. Faulty conditions which are mainly attributed to a reversible processes when something has really been destroyed and remedial actions are needed. A defective conditions (that is high moisture in oil) jeo paradise for occurrence (that is track of discharge), however a critical defective condition (that is presence of liquid water) forms a risk of immediate failure. A faulty condition is a risk of direct failure depending on the stage of fault progressing and functional components involved .The technical life may continue as long as transformer retains its functional serviceability which is determined by its four key proportions.

(a)\Electromagnetic ability and integrity, i.e., the ability to transfer electromagnetic energy at specified conditions including permissible over excitation and over loading

b) Integrity of current carrying circuit.

c) Dielectric withstands strength under the influence of specified operational stresses, considering permissible level of deterioration.

d) Mechanical withstands strength under the effect of through fault current.

A fault occurs when the withstand strength of transformer with respect to one of its key property exceeded by operating stress. The transformer can maintain serviceability while being in faulty condition (overheating, gassing) but it will fail immediately if short circuit or open circuit happens. It is important to distinguish between complete and incomplete failure when the transformer can partly retain serviceability despite some limitation (block OLTC, reduce load, etc)

3.0 The Realities of Transformer Life [3].

The basic traditional philosophy narrates that the life of transformer is the mechanical life of aged paper, and typical criterion to represent the end of life of insulation is the 50% retain tensile strength of the paper. Considering the above paragraph, factors that involved transformer insulation life are:

- Insulation moisture content.
- Oil oxidation.
- Cellulose degradation- Water, CO, CO₂, Furan.
- Insulation structure compression.

Moisture, oxygen and heat are the three ageing accelerators.

3.1 Indicators for assessment of transformer life [3].

Insulation moisture content in oil provides a simple method of estimating residual life. The following guide may be useful (based on equilibrium water content of paper as a function of water content of impregnated transformer oil).

Maximum acceptable- 3%

Entering at risk zone – 4%,

Considerable risk of failure -5-6 %,

Failure imminent - 7%.

For life assessment, emission associated with the insulation ageing process is of interest, principally the level of CO, CO₂ and Furans in the oil. Cellulose degradation can be assessed by furan (HPLC) analyses and preferably supported by degree of polymerization (DP) for more definitive assessment. DP test involves the removal of samples of paper from the winding insulations. Due to the need for internal assess and expensive analysis, the test is only recommended on suspect transformer on the basis of DGA and other test. DP is correlated to the tensile strength. The paper is considered to have no mechanical strength at a DP of 150-200.New transformers have DP above 400.

3.1 Method for moisture measurement:

There are four methods for measurement of moisture which are globally accepted:

1) Direct measurement of water content in paper on layer by layer basis by means of Karl fisher measuring meter (KFMM) using ‘four bar probes’.

- 2) Water content in winding established from measurement of $\tan \delta$ using Gussendaedaur characteristic [4].
 - 3) Water content in winding established from measurement of oil in ppm using Norris diagram.
 - 4) Water content in winding established from RVM (Recovery Voltage Method).
- In this paper, the emphasis has been given on RVM. (Recovery Voltage Method)[6]

3.3 Condition Monitoring Method [5] & [8].

There are three parts in transformer, from where; one can diagnose the nature of faults On-Line/Off-Line. The table no. 2 given below shows the nature of faults and corresponding portion of transformer.

Table-2 (Condition Monitoring)

Sl.No	Methods	Suitable for
1	<u>WINDINGS</u>	
	IR & PI	Moisture and Contaminations Moisture and Contaminations
	DF and Capacitance	Faulted Turns Conduction damage Winding Movement
	Winding Ratio Winding Resistance Impedance & Losses	Poor Dielectrics Poor Dielectrics Detection & location of PD.
2	Applied HV Induced HV & PD PD(Acoustic& Electrical)	Winding Displacement, possibility of loose winding & cores. Moisture & Ageing in paper Slack winding & Mech. Failure Insulation Degradation
	S F R A	
	R V M	Detection of Incipient Fault Over Heating &Ageing of paper Dryness Ageing of oil
3	Vibration Analysis	
	DP	
	<u>OIL</u>	
	DGA & Ratio Analysis Furan Analysis Water Content Receptivity, Acidity IFT & DDF	Moisture and Contamination
	<u>BUSHING</u>	Tan δ

Tan δ or Dielectric Loss Angle (DLA) is a measure of overall quality of insulation system in terms of moisture and contamination.

3.4 Polarization and depolarization current method.

When a dielectric material is charged with an electric field, the material becomes polarized. The current density $j(t)$ is the summation of the displacement current and the conduction current which is given by (1)

$$f(t) = \sigma E(t) + d\delta/dt \tag{1}$$

Where σ is the dc conductivity and $\delta(t)$ is the electric displacement given by (2)

$$\delta(t) = \epsilon E(t) + \Delta P(t) = \epsilon_r \epsilon_0 E(t) + \Delta P(t) \tag{2}$$

Where ϵ_0 is the vacuum permittivity and ϵ_r is the relative permittivity at power frequency (typically 4.5 for cellulose Paper/pressboard and 2.2 for transformer hydrocarbon oil). The term $\Delta P(t)$ is related to the response function $f(t)$ by the convolution integral shown in (3). If we expose the insulation to a step voltage at time $t=0$, the charging current density is given by (4)

$$\Delta P(t) = \epsilon_0 \int_0^t f(t-\tau) E(\tau) d\tau \tag{3}$$

$$i_{Polarization} = E[\sigma + \epsilon_0 f(t)] \tag{4}$$

If we consider the case where an insulation system with geometric capacitance (the geometric capacitance is simply the capacitance of the transformer containing no insulation, just air or vacuum) is exposed to a step voltage, the charging current can be given by (5)

$$i_{Polarization} = C_0 V_0 \left[\frac{\sigma}{\epsilon_0} + f(t) \right] \tag{5}$$

If the step voltage is now disconnected from the insulation, (6) gives the discharging or depolarization current

$$i_{Depolarization} = -C_0 V_0 [f(t) - f(t + t_{charging})] \tag{6}$$

If the response function is to be calculated for a specific time, the charging time normally should be at least ten times larger than this time, then the second term in (6) can be neglected. That is, $f(t + t_{\text{charging}}) \approx 0$, then the response function $f(t)$ is proportional to the depolarization current. Gafvert [9] suggested a technique for calculating simultaneously the response function and conductivity by using polarization and depolarization currents.

To do this, Gafvert [9] also suggested that response function could be expressed in a parameterized form. This can be given as a low order polynomial log $f(t)$ in as shown in (7)

$$\log f(t) = \sum_k C_k \text{Log}(t) \tag{7}$$

Or it can be given as a general response expression as given in (8)

$$f(t) = A / [(t + t_0)^n + (t + t_0)^m] \tag{8}$$

The response function describes the fundamental memory property of any dielectric system and can provide significant information about the insulation material.

4.0. Recovery Voltage Method

When a direct voltage is applied to a dielectric for a long period of time, and then short circuited for a short period, after opening the short circuit, the charge bounded by the polarization will turn into free charges (i.e., a voltage will build up between the electrodes on the dielectric). This phenomenon is called the return voltage. This is shown in Fig. 2 & 3. We assume that the insulation system was initially discharged and that a constant voltage is V_a applied as in (9)

$$V_a(t) = \begin{cases} 0 \rightarrow t < 0 \\ V_0 \rightarrow 0 \leq t \leq t_{\text{charging}} \\ 0 \rightarrow t_{\text{charging}} \leq t \leq t_{\text{discharging}} \end{cases} \tag{9}$$

If we substitute (2) and (3) in (1), we have the following equation as in (10);

$$j(t) = \sigma E(t) + \frac{d\delta}{dt} = \sigma E(t) + \frac{d}{dt} [\epsilon_0 \epsilon_r + E(t) + \Delta P(t)]$$

$$j(t) = \sigma E(t) + \epsilon_0 \epsilon_r \frac{d}{dt} E(t) + \epsilon_0 \frac{d}{dt} \left[\int_0^t f(t - \tau) E(\tau) d\tau \right]$$

... (10)

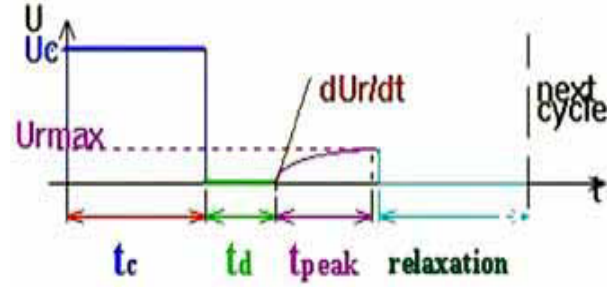

Fig.2. The phases of Recovery Voltage Test Cycle

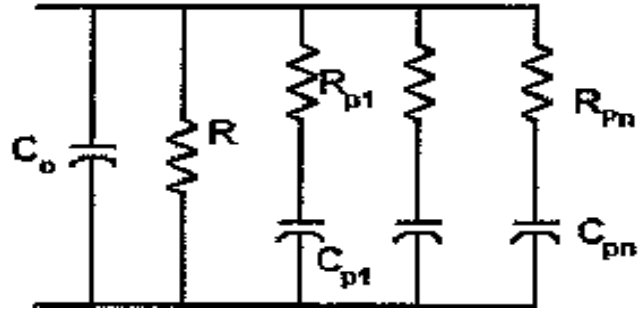

Fig 3 Equivalent circuit of transformer insulation

During the return voltage measurement period, the current density is zero (open circuit condition of insulation). Equation (10) can be solved with. The return voltage can be calculated if the response function, permittivity, and conductivity are known.

4.1 Interpretations of polarization measurement results

A number of thoughts are currently in practice to explain the polarization results. Many of these are explained with case studies [10]–[11], [12]–[13]. Relevant case studies are referred to corresponding reference papers for better understanding of these explanations. Bognar *et al.* [15], [16] reported on the return voltage method and suggested that the insulation structure can be represented by an equivalent circuit as shown in Fig. 3, where C_0 is the geometric capacitance, R is the insulation resistance, and R_{p1} - C_{p1} are substitutes for the individual polarization processes having time constants of $T_{p1} = R_{p1} C_{p1}$. Fig. 3 has been used to represent the extended Debye model, which explains relaxation behavior of oil/paper insulation.

Bognar *et al.* [15], [16] suggest that the initial slope of the return voltage is directly proportional to the polarization conductivity and the maximum value of the return voltage is proportional to the intensity of polarization phenomena and the absolute value of the return voltage maximum value is also influenced by the actual value of the insulation resistance. Osvalt *et al.* [9] describe the difference between transformers of widely differing ages and indicated how the return voltage measurement could be used for this. The closer the return voltage peak is toward the small time constant, the worse is the condition of the transformer. This is illustrated in Fig. 4 [17]

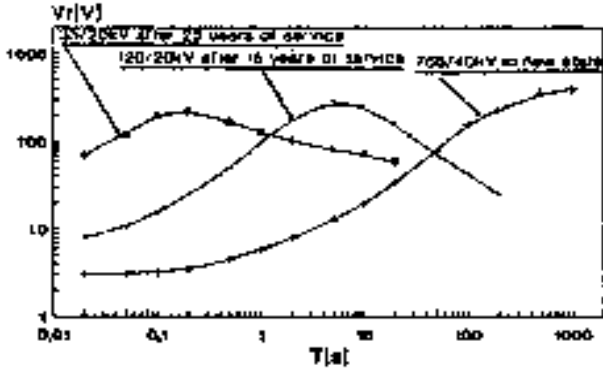

Fig. 4. RV spectra for different ages of transformer

Bognar *et al.* in the paper [15] compares various methods for the diagnostic of oil/paper insulation. Loss factor is found to always change due to the consequence of polarization and conductive effects. Their findings suggest that the central time constant (charge time to peak of the return voltage) is fully independent of the conductivity and of the geometrical capacitance of the transformer insulation, which totally contradicts the suggestion made by Gafvert *et al.* [18]. Bognar *et al.* explain the shift former insulation aging. They acknowledge the difficulties for the interpretation of RV results with reference to test conditions and different designs.

Gafvert *et al.* discuss the polarization process in detail in the [9]. Gafvert and Ildstad [19] present modeling of return voltage based on a series combination of oil duct and paper/pressboard dielectric materials. In their modeling work, each material is characterized by its conductivity and permittivity along with composite dielectric response function. They verified their model with a simplified structural model of transformer insulation.

Their findings suggest that the initial rise of the return voltage (i.e., initial slope) is determined by relaxation of interface charge through the oil gap. They point out that in the case of short charging and discharging times during the return voltage measurement, surface charges completely dominate the magnitude of the return voltage. Ildstad *et al.* in their [20], also present a mathematical simulation tool to describe the fundamental dielectric processes of conduction and polarization. They also explain the relation between time domain and frequency domain polarization measurements.

Gafvert *et al.* in [21] describe a comprehensive mathematical tool to describe the moisture and aging influence on the dielectric properties of transformer insulation. The authors use the geometrical design of a transformer to analyze the polarization response of the transformers insulation. By knowing the appropriate geometry, the composite dielectric constant of oil/paper insulation is calculated based on oil and paper insulation in series connection. Their findings suggest that the initial current during the polarization current measurement is proportional to the oil conductivity and the oil conductivity can be calculated from this current. The impact of oil conductivity on polarization current is demonstrated in Fig.5 [22]. The conductivity of the paper/board can be estimated from the stationary dc current of the polarization current. This stationary current was found to be a good indicator of the moisture content of the paper/board insulation as shown in Fig. 6 [22].

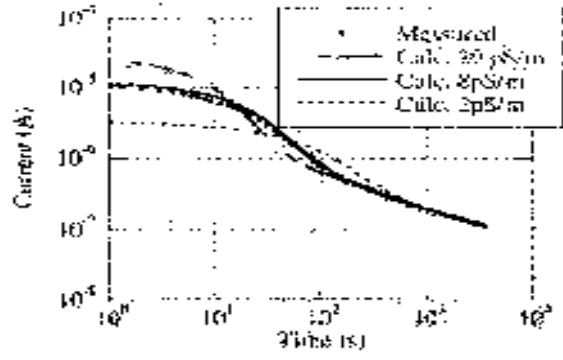

Fig.5.Effect of oil conductivity on polarization current

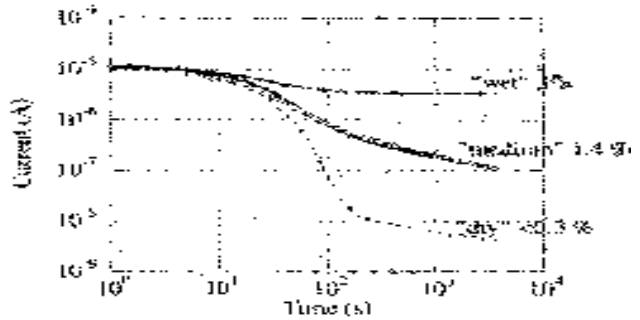

Fig.6.Effect of paper moisture content (paper conductivity) on polarization current.

4.2 Principle of Recovery Voltage Method

If DGA is performed correctly, most of the incipient faults in the oil may be detected. The paper insulation is responsible for containing moisture due to ageing and thermal stresses. The paper insulation may fail under high electrical stress or may release moisture into the oil insulation to detect ageing or moisture content, it is necessary to analyze low frequency part of polarization specimen of dissipation factor. A $\tan \delta$ would have been sufficient but finding a sinusoidal source voltage of 0.001 Hz is very difficult [6]. The alternative method is to adopt recovery voltage measurement. It was found that IR and PI do not reflect complete information on polarization process [2]. Cases have been found when electrical motor having good PI were found to have contamination in windings and, also motors having poor PI have no contamination. To resolve this, 1000 seconds charging and discharging test (DC absorption) was developed.)

The basic circuit for RVM is given in fig (2) below:

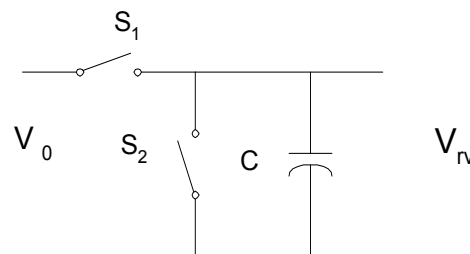

Fig.7. The basic circuit for RVM

Here, V_0 -Charging Voltage (DC), S_1 & S_2 - Switches, Object under Test is capacitor – ‘C’. V_{rv} –Recovery Voltage

Now a day, the water content in paper insulation is determined via moisture measured from oil samples and on the basis of so called dielectric response.

To determine the reliability, the moisture level in the paper insulation, the equilibrium between moisture content in oil and paper is required. The equilibrium state will be reached when transformer will operate at invariable loading, because the concentration in oil depends on temperature to high degree. For majority of transformers, it is not possible to reach ideal equilibrium. Therefore, the moisture content in paper insulation cannot be unequivocally determined on the basis of oil sample analysis.

The recovery voltage method is used to investigate the slow polarization process in the dielectric. This method is based on analysis of curve of maximum recovery voltage versus charging time, so called polarization spectrum. The basic set-up, for recovery voltage measurement, is illustrated in Fig. (3)

The measurement procedure consists of four phases as shown in Fig.(3)

- Charging of test object(Capacitor ‘C’)- S_1 is closed for a time t_c (Charging Time), and the voltage source V_0 applies certain charges to test object C
- Depolarization of test object-Switch S_1 open and Switch S_2 is closed for a time t_d ($t_c/2$) discharging time; the test object is short circuited resulting in dissipation of charging current..
- Recovery voltage measurement- Switch. S_2 is opened, and at the capacitor electrodes the voltage is produced by the residual capacitor’s charges. The maximum and initial slope of recovery voltage is recorded.
- Relaxation of Test Object-After recording of maximum recovery voltage, the switch S_2 closes and test object is short circuited.

The test cycle is repeated using sequence of increasing charging time from a fraction of second to thousands of seconds. Then, the curve of maximum recovery voltage Verses charging time (Polarization Spectrum) is plotted. *The time, at which the maximum recovery voltage is recorded, is called time dominant constant.*

In Fig. 4, it has been shown clearly the four phases of recovery voltage method in principle.

4.3 Practical Test Circuit, Used at Site for RVM

Fig.3&4 show the practical test circuit which is generally used at site for determination of Polarization spectrum. The following key points must be followed before conducting the tests-

- (i) short circuit high voltage windings
- (ii) connect high voltage side to test system ground

- (iii) grounding of high voltage side
- (iv) grounding of Transformer Tank
- (v) short circuit low voltage side and connect to test voltage (Red clip).Be sure that the RVM test voltage should be lower than the rated voltage of connecting windings
- (vi) Bushings must be properly cleansed, and also assure that the test cables have very good contacts.
- (vii) Oil and paper temperature must be stable. Test with insulation temperature blow 10^0 C is not recommended.

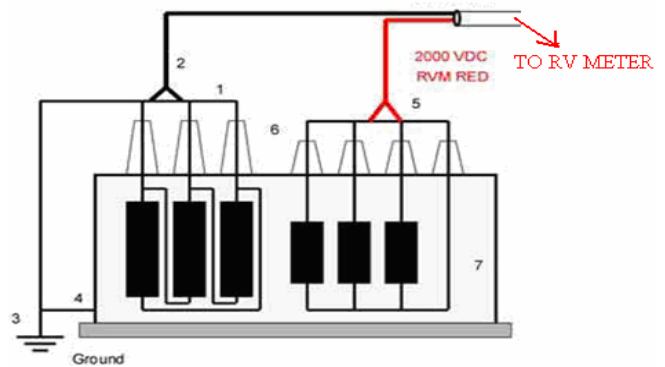

Fig.8. Test Connection for RVM

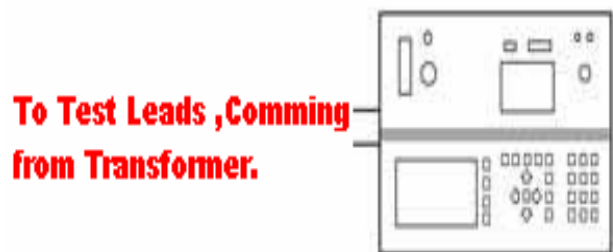

Fig.9. RV METER and its connections

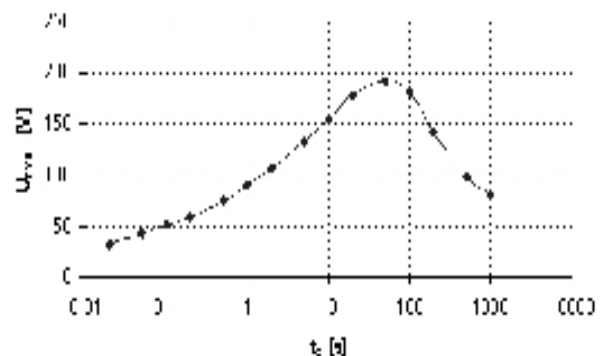

Fig.10. Polarization Spectrum of Power Transformer

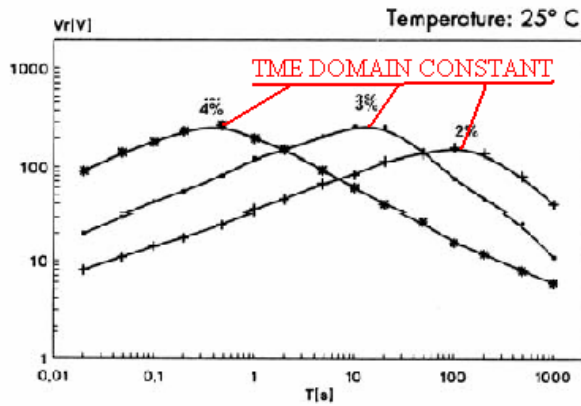

Fig.11. Polarization Spectrum of Oil Paper Insulation

In homogenous insulation of uncomplicated construction, the polarization spectrum received from RVM (Instrument used for above test—Model no. RVM 5462 HUBBFL make), can be connected with dielectric quality e.g. its moisture content. Fig (6), illustrated above, shows the comparison between various moisture content in oil-paper insulation, The polarization spectrum, fig.(6), can be interpreted on the basis of time domain constant. The curve of *maximum time domain constant* has *less moisture content, and vice versa*. The diagnosis of complex insulation system (e.g. Transformer insulation) can encounter plenty of complications. System may have two or more maxima and the interpretation become very difficult. There are also cases when the moisture content of insulation, determined on the basis of polarization spectrum analysis, is higher than in reality.

4.4 Refurbishment Data and Results

Three 66/11 kV, 30 MVA, transformers of 25 years old were refurbished. Some of the important parameters are recorded in Table-1, 2, 3&4 below-

Table- 1

PI	% of moisture (from RVM0)	% of mechanical strength (from DP)
1.1	2.5	40-50
1.8	2.1	40-50
1.8	1.75	40-50

Table- 2

% of moisture estimated from Oil PPM(Norris Diagram)	% of moisture estimated from Winding DLA(CIGRE)	% of moisture estimated from RVM
2	2	1.75
4	3	1.55
2.55	2	2.5

Table-3

% of moisture from (RVM)	DP	% of mechanical strength (from DP)
2.1	250-350	40-50
1.55	250-350	40-50
1.2	200-250	20-30

Table-4

2- Furfural (PPM)	DP	% of mechanical strength (from DP)
1.15	200-250	25-30
0.5	250-350	25-30
0.4	200-250	25-30

Norris diagram furnish estimated percentage of moisture in paper based upon moisture content in oil (PPM) and on temperature. CIGRE paper has established a method to estimate moisture in paper based upon winding Tan δ (DLA) and temperature. It is observed from table-1, RVM follows PI in this case. However, a conclusion can not be slated based on this limited number of observations. Essentially, RVM does follow DC absorption phenomenon and may not follow PI/IR. It has also observed that DP values don't correlate with any electrical parameters DP reflects ageing and mechanical strength of paper, but it is not a diagnostic tool.

From table 2, it is evident that the percentage of moisture estimated from Norris Diagram (based on oil PPM and temperature) and the percentage of moisture estimated from CIGRE publication (based on winding DLA) tends to agree to some extent. However, it doesn't correlate with the percentage of moisture estimated from RVM. This is due to the fact that RVM is total reflection of ageing of cellulose paper and moisture content in the windings. There are not any established methods to separate these two components.

From table-3, it is evident that the percentage of moisture in the winding doesn't correlate to DP.

From table-4, it seems that Furan analysis may, in some cases, indicate about paper ageing. However, most of times, Furan are not detected.

4.0 Conclusion

Mechanical integrity of paper oil insulation is very important factor to ensure the reliability of transformer. Any of electrical diagnostic tools does not reflect conclusive results, on basis of which percentage of moisture content in paper can be detected authentically.

5.0 Future scope

There are only two tools to diagnose percentage of moisture content in paper-oil insulation of power transformer-

- PDC

- FDC

The main feature of the measurement procedure will be a combination of the PDC and FDC measurements [7]. The measurement of PDC in time domain occurs fast, but due to practical limits the upper frequency is limited to 1Hz.

A measurement in frequency domain, on other hand, easily covers frequency up to 5 kHz, but very long for the low frequency range e.g. $f < 1\text{mHz}$.

For Future research work, both the techniques should be combined, because a frequency domain measurement may cover the range from 5000 to 0.1Hz, whereas a time domain measurement may cover 1 to 0.0001Hz or even lower frequencies. A mathematical approximation algorithm converts time domain data to frequency domain for subsequent moisture analysis. The approximation algorithm will allow for a 'forecast' additionally shortening the measurement time

References

- [1] D.allen, "Condition Monitoring & Life Assessment of Aged Transmission / Sub- Transmission Plant", Lecture notes of the short course program on Insulation Condition Monitoring And Reliability Centre Maintenance Of Electrical Plant. February 1997, Monish University.
- [2.] 'GUIDE for Life Management Technique for Power Transformer' (CIGRE', brochure No.227).
- [3.] R.E.James, "Assessment Of Electrical Insulation", Proceedings of the 1998 Residential School in Electrical Power Engineering, Tasmania.
- [4.] I.Gusenbauer, "Examination of Humidity Distribution in Transformer Models by Means of Dielectric Measurements", Cigre paper 15-02, International Conference on Large High Voltage Electric System, 1980.
- [5.] Thomos Leibfried, "On-line Monitors Keep Transformers in Service", IEEE Computer Application in Power, July 1998, pp 36-42.
- [6.] Syed MofizulL Islam, "Power Transformer Condition Monitoring Transformers in Service", IEEE Computer Application in Power, July 1998, pp 36-42.
- [7] H. Borsi, E. Gockenbach, M. Krueger, 'Method and device for measuring a dielectric Response of an Electrical Insulation System' European Patent EP1729139.
- [8] Cajetan Pinto, "An Improved Method of Detecting Contamination of H.V. Stator Winding in the Field", Proceedings of the 20th Electrical Electronic Insulation Conference Boston, 1991, pp. 55-59.
- [9] U. Gafvert, "Condition assessment of insulation systems: analysis of dielectric response methods," in *Proc. Nordic Insulation Symp.*. Trondheim, Norway, 1996.
- [10] M. Darveniza, T. K. Saha, D. J. T. Hill, and T. T. Le, "Investigations into effective methods for assessing the condition of insulation in aged power transformers," *IEEE Trans. Power Delivery*, vol. 13, pp. 1214–1223, Oct. 1998.
- [11] "Diagnostic test method of solid/liquid electrical insulations using polarization spectrum in the range of long time-constants," in *Proc. 7th Int. Symp. High Voltage Engg.*, vol. 9. Dresden, Germany, 1991.
- [12]G. Frimpong, U. Gafvert, and J. Fuhr, "Measurement and modeling of dielectric response of composite oil/paper insulation," in *Proc. 5th Int.Conf. Properties Applicat. Dielectric Materials*, vol. 1. Seoul, Korea, 1997, pp. 86–89
- [13] A. Krivda, R. Neimanis, and S. M. Gubanski, "Assessment of insulation condition of 130 kV oil-paper current transformers using return voltage measurements and an expert system," in *Proc. IEEE Conf. Elect. Ins.Dielectric Phenomena*, Minneapolis, MN, USA, 1997, pp. 210–213.
- [14] R. Neimanis, S. M. Gubanski, B. Homgren, S. Halen, and A. Krivda, "Diagnostics of paper-oil current transformer insulation," in *Proc. Int. Conf. Large High Voltage Elect. Syst. Session Papers*. Paris, France, 1998
- [15] A. Bogнар, G. Csepes, L. Kalocsai, and I. Kispal, "Spectrum of polarization phenomena of long time-constant as a diagnostic method of oil-paper insulating systems," in *Proc. 3rd Int. Conf. Properties Applicat. Dielectric Materials*, vol. 2. Tokyo, Japan, 1991, pp. 723–726.
- [16] , "Diagnostic test method of solid/liquid electrical insulations using polarization spectrum in the range of long time-constants," in *Proc. 7th Int. Symp. High Voltage Eng.*, vol. 9. Dresden, Germany, 1991.
- [17] P. Osvath, G. Csepes, and M.Webb, "Polarization spectrum analysis for diagnosis of insulation systems," in *Proc. 6th Int. Conf. Dielectric Materials, Measurements Applicat.*. Manchester, U.K., 1992, pp. 270–273.
- [18] U. Gafvert, L. Adeen, M. Tapper, P. Ghasemi, and B. Jonsson, "Dielectric spectroscopy in time and frequency domain applied to diagnostics of power transformers," in *Proc. 6th Int. Conf. Properties Applicat. Dielectric aterials*, vol. 2. Xi'an, China, 2000, pp. 825–830.
- [19] U. Gafvert and E. Ildstad, "Modeling return voltage measurements of multi-layer insulation systems," in *Proc. 4th Int. Conf. Properties Applicat. Dielectric Materials*, vol. 2. Brisbane, Australia, 1994, pp. 123–126.
- [20] E. Ildstad, U. Gafvert, and P. Tharning, "Relation between return voltage and other methods for measurements of dielectric response," in *Proc Conf. Rec. 1994 IEEE Int. Symp. Elect. Insulation*. Pittsburgh, PA,USA, 1994, pp.25–28.
- [21] U. Gafvert, G. Frimpong, and J. Fuhr, "Modeling of dielectric measurements on power transformers," in *Proc. Int.*

Conf. Large High Voltage Elect. Syst. Session Papers. Paris, France, 1998.

[22] G. Frimpong, U. Gafvert, and J. Fuhr, "Measurement and modeling of dielectric response of composite oil/paper insulation," in *Proc. 5th Int. Conf. Properties Applicat. Dielectric Materials*, vol. 1. Seoul, Korea, 1997, pp. 86–89.

Biographies



Chandra Kant Dwivedi received the *B.Sc (Engg.)* Degree in Electrical Engineering from B.I.T. Sindri, Ranchi University, India in 1971. He has telescopic experience of more than 32 years in the field of Electrical testing & commissioning of electrical equipments, H.T. & L.T. switch gears at floor level in steel industries. He guided the team

of electrical engineers for testing and commissioning of electrics at Bokaro, Bhilai, Rourkela and Visage steel plant. Since Feb, 2008, he is Sr.Lecturer in Electrical & Electronics Engineering at DIMAT, RAIPUR (C.G). His main areas of interest are High voltage engineering, Testing & commissioning of electrical installations. He is pursuing M.E. Degree by research from Nagpur University, INDIA.



Manoj B. Daigavane obtained the B.E. Degree in Power Electronics Engineering from Nagpur University, India in 1988. He received the M.S. Degree in Electronics and Control Engineering from Birla Institute of Technology and Science, Pilani (Raj) India in 1994. He also obtained the M.E. Degree in Power Electronics Engineering from Rajeev Gandhi

University of Technology, Bhopal (M.P), India in 2001. He received Ph D Degree in Electrical Engineering from RSTM Nagpur University, India in 2009. Since Sept. 1988- June 2007, he had been with the Department of Electronics and Power Electronics Engineering, B. D. College of Engineering, Sewagram (Wardha), affiliated to the Nagpur University, India. Since July 1, 2007 to Apr 30, 2009, he was Professor & Head of Electrical and Electronics Engineering, Disha Institute of Mgmt. and Tech., Raipur (C.G.) where he is engaged in teaching & research. Presently, he is Principal of S. D. College of Engineering, Wardha – Maharashtra (India), since May 01, 2009. His main areas of interest are resonant converters, Power quality issues, DSP applications and Power electronics for motor drives. He has been responsible for the development of Electrical Machines and Power Electronics Laboratories. He is a Member of the Institution of Engineers (India) and a Life Member of the Indian Society for technical Education.