

# Teaching Practice of 'Integration of Theory and Practice' in the Motor Control Course under the Guidance of Moral Education"

Qinghui Zhou<sup>1,\*</sup>, Lei Pan<sup>2</sup>

<sup>1</sup> Institute of intelligent manufacturing, Wenzhou Polytechnic, Wenzhou 325035, China

<sup>2</sup> Zhejiang Mingrui Intelligent Equipment Technology Co., Ltd 325035, China

\* Corresponding author: Qinghui Zhou (Email: 445782257@qq.com)

---

**Abstract:** The article carries out teaching reform in the aspects of teaching content, teaching methods and means, teaching mode, and moral education of the motor course, re-integrates the educational resources of the electrical control technology course, reconstructs the content of subject knowledge, integrates the craftsman spirit of "dedication, lean, focus, innovation" and the industry values of "safety, standardization, pragmatism, efficiency", and carries out a "theory-practice integration" teaching practice that combines online and offline teaching with ideological and political education as the leading factor, simulation experiment design as the main line, classroom theoretical explanation as the auxiliary line, and practical operation as the strengthening factor. It ensures the integration of value shaping, knowledge impartment, and ability cultivation, and implements the goal of cultivating morality and fostering talents.

**Keywords:** Ideological and Political Education, Online and Offline, Simulation, Integration of Theory and Reality.

---

## 1. Introduction

Motor and Electrical Control Technology is an important foundational course for majors such as mechatronics, electrical engineering, and automation [1-2]. The content includes DC motors, transformers, three-phase asynchronous motors, commonly used low-voltage electrical appliances, electrical control circuits of three-phase asynchronous motors, typical machine tool control circuits, etc [3]. This course is closely related to practical applications and is widely used in the electromechanical industry. It has strong theoretical basis and many abstract concepts. Circuit analysis and working principle analysis sometimes require appropriate approximation processing [4]. However, due to the lack of practical experience among students, some of them may have a vague understanding of the theoretical analysis and practical application of the course, which is a problem that we need to explore and solve; The reform of the integrated teaching model of theory and practice must break the traditional disciplinary system, use projects as carriers, integrate the cultivation of knowledge, skills, and literacy, and enable theoretical learning and professional practice to be completed in the same time and space. At the same time, information technology teaching should be integrated to improve the quality of talent cultivation [5]. In addition, vocational colleges aim to cultivate students with professional skills, so they need to experience more practical work scenarios during the learning process. Traditional practical training is difficult to provide more practical environments, so corresponding electrical simulation software can be introduced into different work scenarios, in which students practice the operational skills required for different positions. At the same time, cultivate students' engineering awareness (including safety production awareness, quality awareness, and economic awareness) and labor awareness; Cultivate students' teamwork ability, a rigorous and pragmatic scientific attitude, and a spirit of craftsmanship that strives for excellence;

Cultivate the ability of students to acquire relevant knowledge and information by reading product manuals and collecting information online; Cultivate good study habits and lifelong learning concepts among students, achieve self-management learning, and lay the foundation for sustainable development [6].

Based on my practical teaching experience in the motor course, the author carried out teaching reform from the aspects of teaching content, teaching methods and means, teaching mode, moral education teaching, etc., to help students better master the theoretical knowledge of the course and improve their practical ability. At the same time, focusing on the six aspects of firming ideals and beliefs, cultivating patriotism, strengthening moral cultivation, increasing knowledge and insight, cultivating the spirit of struggle, and enhancing comprehensive quality, the author integrated the craftsman spirit of "dedication, lean, focus, and innovation" and the industry values of "safety, specification, pragmatism, and efficiency" into the whole process of teaching construction, focusing on shaping the values of patriotism, honesty, friendliness, safety standards, lean and pragmatic, innovation and efficiency, so that students can accurately design control schemes, precise operations, and parameters. Set up and carefully develop control procedures Fine debugging of control circuits, lean and pragmatic solutions to enterprise problems, and becoming a technical and skilled talent with the characteristics of "precise control, pragmatism and efficiency creation" in the field of control integration.

## 2. Thoughts on Curriculum Teaching Reform

By integrating the education and teaching resources of the electrical control technology course, according to the guiding ideology of "Cognition Simulation Practice re cognition re practice", integrating the elements of Ideological and political education, re designing the teaching, re arranging and

combining the knowledge of each part, taking the ideological and political ingenuity of the course as the guide, taking the simulation experiment design as the main line, taking the classroom theory explanation as the auxiliary line, and taking the practical practice as the reinforcement, re-integrating the knowledge points, and teaching students the relevant theoretical knowledge and operating skills in the process of completing the experiment, so that students can directly participate in, experience, feel, demonstrate and explore the whole process; Develop course learning resources on the superstar learning platform, establish a digital teaching environment based on computer simulation experiments, collect, integrate, redevelop and transform the knowledge content of the subject into several "teaching experiments", and carry out teaching around the experimental organization.

In order to ensure the integration of value building, knowledge transfer and ability training, and implement the goal of Building Morality and cultivating people, the following key issues should be solved:

(1) Explore the organic combination of theory teaching and simulation experiment teaching, enhance students' interest and mobilize students' enthusiasm, and achieve the goal of guiding students to improve their learning methods. When learning electrical control, many students are exposed to various components for the first time and do not have deep perceptual knowledge. If students do not have enough interest in learning, it is difficult to maintain high learning enthusiasm and efficiency. Therefore, teachers should consider this point when applying simulation technology. They should not only simulate the essence of the problem, but also guide students to a certain application scenario. Students can more directly understand the application of electrical control technology in the scenario, which is conducive to deepening students' understanding of relevant knowledge and improving students' interest in learning.

(2) Explore the role of simulation technology in the practice teaching of electrical control technology, through the application of simulation technology, optimize the experimental teaching, and improve the learning efficiency of students. Provide students with simulation experiment demonstration in the classroom, and introduce the experimental teaching into the classroom. After learning part of the theoretical knowledge, students can watch the corresponding demonstration experiment, which can timely change the learning mode, help to open up ideas and deepen students' understanding of relevant knowledge. The application of simulation technology is different from the actual experimental teaching. It does not need to move all kinds of instruments from the laboratory, nor does it occupy the space of teachers. It is also very simple to operate, which can play a role in the maximum efficiency and provide students' learning efficiency.

(3) Select simple and easy-to-use simulation software, and explore a variety of comprehensive simulation applications. To achieve a complete engineering task, first of all, according to the control requirements, each component in the system should be represented by the specified graphics and text symbols and connected into a system according to certain requirements, and then the schematic diagram of the system should be drawn. Then, the electrical components should be laid out, the installation wiring diagram should be drawn, and the components should be connected according to the wiring diagram for operation test and troubleshooting. This requires the simulation software to introduce the use methods and

precautions of common electrical tools and measuring instruments, the animation structure and electrical symbols of common electrical appliances, circuit schematic diagram, component layout, wiring and operation demonstration, troubleshooting and other aspects. Select the appropriate simulation software, through the application of simulation technology, analyze the operation principle and design essentials of electrical control technology, and fully deepen students' learning of electrical control technology, so as to facilitate college students to master and apply the relevant technologies and theories of electrical control. It should be noted that while applying simulation technology and exploring a variety of comprehensive simulation applications, we should master the key points of classroom teaching. Simulation technology is only a necessary means to assist college teaching, not the main teaching content.

### **3. Main Contents of Instructional Design**

#### **3.1. Integrated Teaching Design of Motor and Electrical Control Course based on the Concept of "Integration of Theory and Practice"**

Based on the application of simulation technology in the course of electrical control technology, we have an in-depth understanding of the advantages and disadvantages of simulation technology. Through repeated demonstration and experiment, we can effectively find out the problems that may occur in the teaching process of simulation technology and deal with them. At the same time, we can explore the design of learning experiments that are close to real life and highly practical by combining the situational teaching method, the theory and practice integration teaching method, the mutual communication teaching method, the active participation method, the autonomous learning method and other teaching methods, closely combining with the actual engineering operation, and analyze the knowledge points involved in the experiment by using the simulation software. Combined with the syllabus and teaching process, we can reasonably design the teaching program of electrical control technology, and clarify the proportion of unit theory teaching, simulation teaching and students' practical operation, so as to promote the orderly development of classroom teaching activities.

(1) According to the mode of "project oriented task driven learning and doing in one", taking the motor control circuit commonly used in the factory as the main carrier, five modules and 14 project tasks are designed. The task requirements are designed according to "control task analysis - device selection - control circuit principle analysis - control circuit installation and wiring - debugging and troubleshooting". Arrange teaching with skill points as the main line, explain necessary knowledge points at the same time, and learn while practicing.

(2) According to the law of progressive ability, the new ecology of teaching is carefully constructed, and the three-stage teaching is designed to promote students' new technology learning. Before class, students study on the short screen on the superstar learning platform and complete the knowledge test before class; In the course, by focusing on the teaching focus and difficulties of this course, and using the electrical skills and practical training simulation teaching system to set tasks, students' classroom simulation

exploration and complete the tasks, and carry out practice, the teacher comments, and explains the key and difficult points; After class, students will re learn from the short screen on the

superstar learning platform and complete consolidation exercises after class.

**Table 1.** module task design

No.	module	Ability training tasks	Suggested credit hours
1	Unidirectional direct starting control of motor	Task 1.1 manual control of three-phase motor Task 1.2 three phase motor inching control Task 1.3 one way operation control of three-phase motor	12
2	Motor forward and reverse control	Task 2.1 forward and backward control of electric hoist Task 2.2 automatic round trip control circuit of workbench	8
3	Motor starting control	Task 3.1 three phase motor delayed start control Task 3.2 sequence control of three-phase motor Task 3.3 star delta step-down starting control of three-phase asynchronous motor	12
4	Motor braking/speed control	Task 4.1 reverse braking control circuit Task 4.2 energy consumption braking control circuit Task 4.3 speed control of three-phase asynchronous motor	12
5	Typical machine electrical control	Task 5.1 X62 universal milling machine control circuit reading Task 5.2 circuit analysis and debugging of X62 universal milling machine control circuit Task 5.3 troubleshooting of X62 universal milling machine control circuit	12

3) Using the evaluation method of combining process and final examination, it mainly evaluates the students' classroom performance, task completion, etc., and carries out the final examination through the paper.

### 3.2. Implement the Fundamental Task of Building Morality and Cultivating Talents and Integrate the Elements of Education

The Wenzhou spirit in Wenzhou Ouyue culture is an important ideological and political source for shaping the humanistic background. The innovation and efficiency values of the motor integration industry are an important ideological and political source for shaping the innovation concept. The craftsman spirit and national feelings of "robot replacement" to help the manufacturing power are important resources for the ideological and political ingenuity of the curriculum. Around the six aspects of firming ideals and beliefs, cultivating patriotism, strengthening moral cultivation, increasing knowledge and insight, cultivating the spirit of struggle, and enhancing comprehensive quality, the craftsman spirit of "dedication, lean, focus, and innovation" and the industrial values of "safety, standardization, pragmatism, and efficiency" are integrated into the whole process of teaching construction, focusing on shaping the values of patriotism, honesty, friendliness, safety, standardization, lean and pragmatic, innovation and efficiency.

By means of positive and negative education cases, animation videos, breakthrough games and other forms, the ideological and political points of patriotism, love of family, love of work and dedication, lean and pragmatic are skillfully cut through personal experience, teachers' messages and other ways, and through the links of students' self-evaluation, students' mutual evaluation, teachers' comments and so on, the integration of value building, knowledge teaching and ability training is ensured to be realized, and the goal of

morality and talent cultivation is implemented.

### 3.3. Develop Course Superstar Online Learning Resources

The development of teaching resources such as videos and animations for the theoretical part of motor and electrical control technology, covering the theoretical teaching videos and animation resources for the structure and working principle of motor foundation, low-voltage apparatus and basic control circuits, including DC motor, three-phase asynchronous AC motor, single-phase motor, servo motor, stepper motor, relay contactor button switch, as well as videos for the principle explanation of basic control circuits such as inching, continuity, sequence, self-locking and interlocking, automatic circulation, can ensure that students can predict, review and test online teaching resources in their spare time in combination with classroom learning, and effectively support online and offline hybrid classroom teaching. Using the course platform can quickly evaluate the objective test questions and summarize the results, which is convenient for teachers to accurately grasp the learning situation and adjust teaching strategies.

### 3.4. Creating Virtual Simulation Platform for Electrical Control Circuit

At present, when conducting electrical control experiments, relays and contact controllers are two key components. The electrical control specialty has power supply wires and other related parts. Using Cade simu software, a teaching platform for basic control circuit schematic design and simulation verification can be built. When simulating common electrical parts such as contactors, students can use this platform to realize the control principle of contactors and relays, and then find out the relevant principles and simulation diagrams. Students first design the schematic diagram, then

use the software to process the simulation and start the operation.

Cade\_simu is an excellent analog electrical circuit simulation software, which provides a variety of commonly used electrical circuit component symbols, which can be directly called by users to help users easily draw electrical circuit diagrams, simulate operation, and support single-step simulation. Through the simulation function of the software, students can observe the action process of the control circuit, which is a good computer-aided tool for students to understand the principle of the control circuit and help them design new control circuits. The following figure shows an electrical schematic diagram of the positive and negative rotation of the motor. In the past teaching process, the teacher gave the schematic design task, and the students designed the positive and negative rotation control schematic diagram according to the requirements, and drew it on the training report. With cade\_simu software, students can design the circuit diagram according to the teacher's task requirements in the software, and carry out simulation inspection.

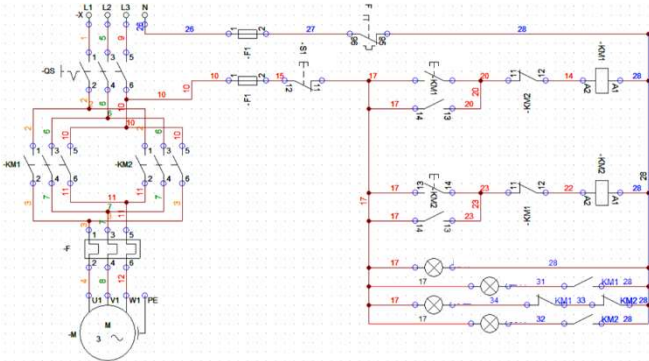

Figure 1. CADE\_SIMU software example

### 3.5. Designing Simulation Experiment in Theory Teaching

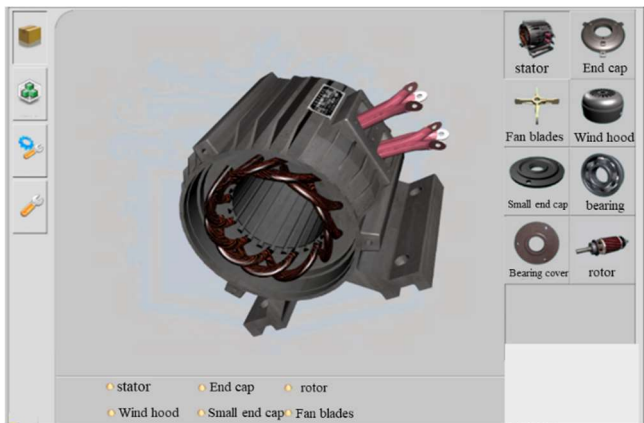

Figure 2. Theoretical cognitive simulation experiment example

By making full use of the existing teaching resources of the school, introducing the electrical skills and training simulation teaching system, integrating the existing teaching resources of electrical control courses, extracting and summarizing the theoretical knowledge in the practice of electrical control technology, five electrical theory experiment teaching projects based on the simulation platform and seven low-voltage electrical theory experiment teaching projects are designed in the teaching course, including three-phase asynchronous motor, single-phase

asynchronous motor, servo motor, stepping motor, DC motor, contactor, relay, circuit breaker, fuse, button switch structure understanding, assembly simulation, maintenance test and other simulation projects; Guide students to carry out simulation experiments, stimulate students' interest and improve students' theoretical cognition of electrical control technology.

### 3.6. Design the Wiring Debugging and Operation Experiment of the Training Device based on Virtual Reality Combined with Simulation

In view of the connotation of the development of high-quality vocational education under the "double high" plan, the existing training device of our school is fully used in combination with the virtual simulation platform of electrical control circuit to design the practical experiment. Including: 8 aspects of practical operation experiments of three-phase asynchronous motor, including inching continuous control, forward and reverse control, delayed start control, sequence control, cycle control, star delta step-down start, speed control and energy consumption braking; During the implementation of "theory practice integration" teaching, before the wiring debugging of the training device, the students should be guided to first complete the schematic drawing, virtual contact relay system wiring debugging and Simulation on the simulation platform. After success, the students will have more confidence and better effect when conducting the wiring debugging on the actual training device.

## 4. Teaching Practice

(1) Implement the "three integration and one through" Ideological and political teaching mode

The teaching team of the course organically integrates "Ideological and political elements" such as the professionalism of love and dedication, the spirit of unity and cooperation, the work style of precise control and the spirit of pragmatic and innovative spirit into the curriculum standard of industrial robot technology application. With the cultivation of "craftsman spirit" and the creation of stable "industry values" as the soul, the teaching team implements the "three in one through" teaching mode, integrates ideological and political education into the learning objectives, and promotes students' desire to learn; Integrate into the learning content to promote students' knowledge and learning; Integrate into learning methods, promote students' learning, run through the whole process of teaching, and promote students' love of learning.

(2) Implement online and offline teaching process

Taking superstar learning link as the teaching platform, the course has built an online course covering learning resources such as ideological and political videos, pictures and courseware to support the implementation of Ideological and political education before, during and after class. The hybrid teaching of online and offline combination effectively realizes the "three complete" educational goals of combining indoctrination and infiltration, theory and practice, positive guidance and negative education, and learning and evaluation.

(3) Follow the principle of promoting learning through evaluation, promoting thinking through evaluation, and innovating teaching evaluation

Implement the "three complete education" concept, build a diversified and collaborative evaluation system, and connect

the evaluation content with the three-dimensional goal of Integrating Ideological and political elements, so as to comprehensively promote students' success; Formative evaluation runs through the whole process of curriculum teaching, connects with teaching links and stage growth, and pays attention to value-added evaluation at the same time; Business mentors focus on pragmatic norms, teachers focus on goal effectiveness, students focus on process participation, and all staff participate in collaborative evaluation, which urges students to attach importance to curriculum ideological and political education and shape stable value pursuit.

Take the installation and maintenance of three-phase asynchronous motor forward and reverse control circuit as an example:

Before class, the pre class video learning task of the installation and maintenance of the forward and reverse control circuit of three-phase asynchronous motor was released on the superstar learning platform. Students click the corresponding video to learn and complete the pre class knowledge test, so as to cultivate the awareness of autonomous learning and team cooperation.

In the class, the teacher explained the key points of the forward and reverse control circuit of three-phase asynchronous motor according to the learning situation, and gave the goal of learning or task - to achieve the goal of motor forward and reverse control, and gave the control requirements, and issued the design of the schematic diagram of student task 1: students used cade\_simu software to design and simulate the electrical schematic diagram, and then issued the design of the wiring diagram of task 2: students used the electrical simulation teaching software system to carry out virtual wiring and test of the control circuit, step by step autonomous exploration, and cultivate practical confidence; After the completion of the release task, complete the equipment operation connection and line inspection on the hardware platform, guide and cultivate the consciousness of standardization and 6S; After the completion of task 3, students will conduct mutual evaluation, guide continuous optimization control and pursue excellence; During the task, the teacher made a flexible process evaluation on the students, and summarized and explained the common problems.

After class, complete the knowledge consolidation test of this course on the learning platform, and release the expansion tasks as appropriate. The team cooperates with the real project of the enterprise to solve the actual problems. The circuit principle design is saved by using cade\_simu software, and submitted to xx CAD files, sharpen professional skills, and cultivate practical and effective professionalism.

## 5. Conclusion

By integrating the education and teaching resources of electrical control technology course, the course establishes a digital teaching environment based on computer simulation experiment, collects, integrates, redevelops and transforms the knowledge content of the subject into several "teaching experiments", and timely integrates the craftsman spirit of "dedication, lean, focus and innovation" and the industry

values of "safety, standardization, pragmatism and efficiency" into the whole teaching process around the experiment; According to the guiding ideology of "Cognition Simulation Practice re cognition re practice", the teaching design is re arranged and combined. Guided by ideological and political education, the simulation experiment design is the main line, the classroom theory explanation is the auxiliary line, and the practical practice is the strengthening. The knowledge points are re integrated. In the process of completing the experiment, the students' relevant theoretical knowledge, professional values and operating skills are taught, so that the students can directly participate in, experience, comprehend, demonstrate, explore and shape the value in the whole process; By studying and establishing the resources of electrical control course based on the integration of theory and practice, the information sharing and exchange between teachers can be promoted.

## Acknowledgments

This paper was supported by Zhejiang Provincial Curriculum Ideological and Political Demonstration Course "Integrated Application Technology of Industrial Robot Workstation" (Zhejiang Provincial Education Department Document [2022]51), Zhejiang Provincial Education Science Planning 2023 Annual general planning project "Teaching Practice Exploration of Deepening School-Enterprise Cooperative Education Based on Digital Twin Technology -- Taking Industrial Robot Integrated Application Technology Course as an Example" (Project No.: 2023SCG215), Research on the Teaching Mode of "Theory Virtual Reality Integration" in the Course of Motor Electrical Control under the Background of "Double High"(WZYYB202007).

## References

- [1] Zhangmeifeng, gaoyunxia, houyonghai. Teaching reform and practice of motor related courses in automation specialty [J] Journal of Chifeng University (NATURAL SCIENCE EDITION), 2016, (1): 269-270.
- [2] Zhou Yang, Cui Yirong, reform and practice of teaching methods for motor drive technology [J]. science and education forum, 2018, (4): 34-35.
- [3] Sucuiyun. Discussion on the teaching method reform of motor and electrical control technology in Higher Vocational Colleges [J]. China Adult Education, 2015, (07).
- [4] Zhuang Cunbo, Liu Jianhua, Xiong Hui, et al. Connotation, Architecture and Development Trend of Product Digital Twin [J]. Computer Integrated Manufacturing Systems, 2017, 23 (4) :753-768.
- [5] Wangyiping, Chen Yuan. Exploration on curriculum reform of pharmaceutical specialty in Higher Vocational Colleges Based on "integration of theory and practice" [J]. teaching and practice, 2015, (07).
- [6] Wangyunwu, wangyuru, liyanxin, et al. Countermeasures and suggestions for improving the quality of online education during epidemic prevention and control [J]. China medical education technology, 2020, 34 (2):119-124+128.