

## **THE ROLE OF MINIMALISM IN ANALYZING KIBHWANJI DP STRUCTURE**

**Sulemana, A. R.**

Dar es Salaam, Tanzania

---

**Abstract:** This paper explores the Structure of the Determiner Phrase in Kibhwanji, a Bantu language spoken in the southern highlands of Tanzania, using the Minimalist Approach. The study focuses on establishing the functional categories that head the DP and examining the order of modifiers. Data was collected through acceptability judgement, document review, and focus group discussion. Findings reveal that the functional categories that head the DP in Kibhwanji are augments, pronominal possessive formative -nya, and pronominal demonstratives. Modifiers may range from one to six, yielding the order (DEM)/(AUG)/(DISTR)/(POSS) > N > POSS > QUANT > DEM > NUM > ADJ > REL. The study employs the Minimalist Program and Abney's DP Hypothesis to explain the correspondence between the DP and IP and to propose that the determiner heads the noun phrase. The research contributes to the literature on DP studies in Bantu languages, highlighting that despite being an articleless language, Kibhwanji language is amenable to projecting a D functional category above nP.

---

**Keywords:** Bantu languages, determiner phrase, Kibhwanji language, Minimalism, Structure.

### **Introduction**

The postulation that a noun phrase is headed by a determiner as its head is widely accepted in linguistic circles. However, identifying the exact elements that constitute functional categories has proved challenging, especially for Bantu languages. This paper examines the Structure of the Determiner Phrase in Kibhwanji, spoken in the southern highlands of Tanzania, using the Minimalist Approach. The study aims to establish the functional categories that head the DP and to examine the order of modifiers. Data was collected through acceptability judgement, document review, and focus group discussion. The research reveals that the functional categories that head the DP in Kibhwanji are augments, pronominal possessive formative -nya, and pronominal demonstratives. Modifiers may range from one to six, yielding the order (DEM)/(AUG)/(DISTR)/(POSS) > N > POSS > QUANT > DEM > NUM > ADJ > REL. The study employs the Minimalist Program and Abney's DP Hypothesis to explain the correspondence between the DP and IP and to propose that the determiner heads the noun phrase. The research highlights that, despite being an articleless language, Kibhwanji language is amenable to projecting a D functional category above nP, which is a valuable contribution to DP studies in Bantu languages.

### **Theoretical Framework**

This study shoulders on a Minimalism Program (MP) and, Abneys' (1987) DP Hypothesis. The former emphasizes correspondence between the DP and IP (Chomsky, 1995). The theory pursues the replacement of the intricate apparatus and government and binding (GB) theory processes with minimal simple and general

principles of sentence structure (Chomsky, 1995). In applying this theory, the study uses three structural building operations, namely; merge, move and agree. Merge is the operation that takes pairs of syntactic objects and places them by a new combined syntactic object (Chomsky, 1995). This procedure ascends due to the requirement to group words into constituents or join two or more syntactic categories and purposes to build up larger structures from smaller ones in a bottom up fashion. This operation was useful in the analysis of Kibhwanbi DP because elements which occur within the DP need to be combined (for instance phrasal category nP with the functional D-head) to build up larger structure in the derivation process. Move (also called 'attract' operation) is an operation that dislocates items from their merged positions to new structural positions forming a chain between the moved elements and its copy (Sulemana, 2012). According to Chomsky (1995), this operation is motivated by morphological considerations where some features must be checked. Chomsky, further, points out that movement is always an operation that takes place leftwards since heads and specifiers (which are the only positions to move to) are always to the left in the tree. Agree, is an operation that establishes the relationship between two or more elements in the structure. Chomsky (2000) argues that agree is taken to be a result of a process known as feature checking between the goal (also called controller) and a probe (target).

Apart from the minimalist program (MP), the study uses the DP Hypothesis which was propounded by Abney (1987) and later on advanced by Longobardi, (1991); and Bernstein (2001). According to this hypothesis, the determiner heads the noun phrase. As such, the DP represents the extended, and maximal, projection of the lexical head. The DP hypothesis contrasts the traditionally held view that the noun phrase is the projection of the noun. In such cases, determiners occupy the specifier position of N. Consider the structural derivation in the following diagrams:

(1) (a). The NP analysis

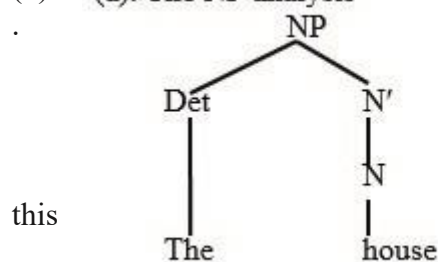

b. The DP analysis

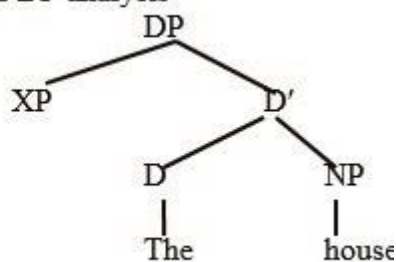

The structure in (1a) above, indicates that the noun is the locus of the determiner category. In case it is the noun (N) which heads the phrase thereby yielding the NP

hypothesis. In (1b) the head D selects the complement NP to form the intermediate D' which in turn merges with the specifier (Spec) to form the maximal projection DP. This analysis considers the functional category DP as an extended projection of the lexical noun.

### The Concept of Determiner (D)

In linguistic literature, the term 'determiner' is related to three senses. First, a determiner is regarded as an element which appears with a noun either to the noun or to add extra information about that noun. In this definition, a determiner is considered the same as other modifiers such as relative clauses, adjectives, genitive constructions, articles, demonstratives, possessives, numerals, quantifiers, and adjectives are all viewed as nominal modifiers, an overarching class (Visser, 2008). Second, a determiner entails a specific category incorporating items whose principal function is to restrict the reference of nouns with which they occur (cf. Alexiadou, et. al., 2007; Lyons, 1999). Looking at the determiner in this sense, Lyons (1999) argues that, a noun can be restricted so that it is understood to be as either definite or indefinite, specific or non-specific, identifiable or non-identifiable. In this sense, articles and possessives qualify as members associated to these functions. In addition, possessives and articles, cannot co-occur in the same NP (e.g. \*my the house\*) as because they occupy the same syntactic position that is why they are included in the category of determiner. This holds truth with English language many other Germanic languages in which, according to Payne (2006), a class of determiners include items, which mutually exclusive. According to Nweze (2014), determiners

display a sensitivity of structuring the real world entities that speakers and hearers use when making their references explicit to one another. This structuring sets the restrictions with which the logical uniqueness of definite description holds. The third sense considers a determiner as a functional head that occurs as a specifier, and/or the complement of the head noun (Borer, 2005; Giusti, 2015). This head noun can be phonetically realised (overt) or unrealised (null). A phonetically unrealised head is termed as pro (Radford, 2009). For the purpose of this study, I employ the third sense of the determiner, in which according to Zamparelli (2000), the determiner projection turns out to be the category that introduces the noun phrase. Using this perspective, this study, therefore, shows that Kibwanbi language, despite being an articleless language, is amenable to projecting a D (determiner) functional category above nP.

### **DP Studies in Bantu Languages**

Regarding the order of modifiers in world languages' DPs, Cinque (2005) provides the structure which stands as a typological basis for DP structures across languages. He asserts that the underlying order is determiner+numeral+adjective+noun. However, there are other languages that exhibit a different order. Cinque notes that, if there are variation in order by other language this variation is accounted for by means of movement of modifiers or elements between the determiner category and noun. In Bantu languages, numerous studies have been conducted on the structure of DP (cf. Basweti, 2014; Carstens, 1991, 2008; Mose, 2012; Ndomba, 2017). Carstens (1991) studied the morphology and syntax of DP in Kiswahili language using the DP hypothesis. Carstens (1991) argues that the noun phrase in Kiswahili is embedded within two functional categories, namely number phrase (numP) and determiner phrase (DP). Carstens, further, proposes that in Bantu languages (Kiswahili inclusive), the noun rising to the empty determiner position yields the surface noun-initial order and that the genitive pronouns occupy the specifier position of the number phrase. Additionally, Carstens (ibid) proposed that, in Kiswahili, all arguments of N originate NP - internally. Carstens (2008) compared between Bantu languages and the Romance languages in such aspects as noun class and grammatical gender, derivational properties, ordering among nouns and their modifiers, and agreement pattern (concord) in DPs. Carstens (2008) concluded that Bantu and Romance share a common class gender system with gender-specific Spell-Out of number features. A second note is that gender/class is an uninterpretable feature, without derivational functions, despite some surface evidence to the contrary. Lastly, DPs of the two languages share a common structural design and that agreement in the DP-internal in both language families is the result of the Agree relation.

Ndomba (2017) investigated the configuration of the Determiner Phrase (DP) of Swahili using cartographic approach of the minimalism program. According to Ndomba (2017), the Swahili DP structure is underlying the same as the English DP except that, in Swahili DP, nP raises to Spec DP (XP movement). Second, it was revealed that the underlying order of the elements in Swahili DPs have the same underlying structure relations as the English demonstrative, numeral, adjective, and noun – those three beautiful children. Nevertheless, Ndomba cautions that the head noun-initial surface structure of Swahili elements stems from nP movement to the initial position, Spec DP, which results in the opposite order – children those three beautiful. Ndomba (ibid), departs from Carstens' (1991), which posited that Swahili DP projects a null D to which the head noun raises (head-to-head movement). Instead, Swahili DPs are derived via the movement of XP functional category; NumP or nP to Spec DP via successive stages.

Basweti (2014) examines the Ekegusii DP in a view to ascertain the applicability of the M.P in analyzing the Ekegusii Determiner phrase. The study revealed that the functional category heads the DP in Ekegusii and the NP stands as a lexical complement of the DP. Baswet, further, notes that the principles of feature checking and full interpretation in the minimalist program are equally crucial in ensuring that Ekegusii constructions (DP and even the sentence) are grammatical (converge). This accentuates the fact that the MP is suitable in Ekegusii DP analysis. Regarding agreement and movement of elements, it has been revealed that the agreement system in Ekegusii is best captured by feature checking. Meanwhile, movement of the elements is aimed at checking agreement that is between the noun and its determiners.

## Research Materials and Methods

This study involved both primary data and secondary data collected in Njombe region (Southern Highlands of Tanzania). Specifically, the data were collected from three villages namely Matamba, Ikuwo and Magoye in Maketedistrict which is the native land of Kibhwanbi. The data were collected through three methods, namely; acceptability judgement, documentary review and focused group discussion (FGD). Participants of the study were five native speakers of Kibhwanbi. As for primary data, a list of sentences containing various DPs were presented to the participants. In the first instance, each participant was asked to judge whether the sentences are correct and acceptable. Second, all five participants were brought together in a discussion (FGD) to level the idiosyncrasies that could be displayed from an individual respondent. Such questions like the following were asked: What do you call X in Kibhwanji? How do you say Y? How do you describe a person who is tall, small and angry in Kibhwanji?. Such questions provided information on the different realizations of the DP, co-occurrence possibilities of element(s) that form the DP. With regards to secondary data, a Bible written in Kibhwanbi, three Bible story books written in Kibhwanbi and one traditional tale book called “ikitabukyaFipangofyaKibhwanbi (The Book of Kibhwanbi Tales)”, published in 2009 with thirty-nine (39) short traditional tales were obtained. From these sources, various sentences with DPs containing coordinated nouns were extracted to complement the data obtained through acceptability judgement and focus group discussion. Data were then analysed using descriptive framework.

### The Structure of Kibhwanji Noun and the DP

The structure of Kibhwanbi noun consists of an augment (AUG), a class prefix (CL) and the noun stem(NS). Based on the distribution the following noun template can be established: AUG-CL-NS. Like many other languages in the Bantu language family, Kibhwanbi has an articulated noun class system with nineteen (19) noun classes. Most nouns are assigned to two classes, one in singular and the other in plural,

Table 1 above shows that the augment in Kibhwanbi is one of the vowels *a-*, *i-*, *i-* and *u-*. The augment *a-* is found in classes, 2, 6, and 12 as shown in the following examples: *a-bha-na* ‘the children’, *a-ma-vue* ‘the stones’ and *a-ka-pene* ‘the small goat’. The augment *i-* is found in classes, 8 and 10 as in the following examples: *i-fi-tengo* ‘chairs’ and *i-mbunda* ‘the clubs’. The augment *u-* is found in classes 1, 3, 11, 13, and 14 like in: *u-mu-hinja* ‘the lady’, *u-mwe-nda* ‘cloth’, *u-tu-pene* ‘the small goats’, and *u-bh-u-ghale* ‘the maize meal’. The augment *i* is found in classes 4, 5, 7, and 9 like in: *i-my-enda* ‘clothes’, *i-li-vue* ‘the stone’, *i-ki-tengo* ‘the chair’, and *i-mbunda* ‘the club’.

### An Augment as Determiner Category

The study has shown that one of the elements that can occur, as a determiner, is an augment. According to de Velde (2019) the term ‘augment’ is used by Bantuists to refer to an element that precedes the class prefix of nouns and some adnominal or nominalised modifiers and that changes the class assignment neither of the noun, nor its lexical meaning, nor the syntactic positions it can occupy. The shape of the augment always corresponds to the vowel of the noun class prefix of the given class like most Bantu languages. As shown in example (2) below the vowels *a-*, *i-* and *u-* are the augments.

(2). (a). *u-mu-unu*

AUG-CL1-person

‘the person’

(b) *a-bh-i-mbi*

AUG-CL2-singer

‘the singers’

(c) *i-my-aka*

AUG-CL4-handle

‘the big handles’

(d) *i-li-vue*

AUG-CL5-stone  
 ‘the stone’

Examples (1) (a-d) show that the augment in Kibhwanbi occurs as a vowel. Data suggests that, the augment can be analysed as the spell-out of a determiner category dominating the DP in Kibhwanbi. Consider the following examples.

(3) u-m-bili                      mu-nono  
 AUG-cl3-bili                  cl3-beautifu

‘the beautiful body’

The Phrase Structure of the DPs above would be as follows”

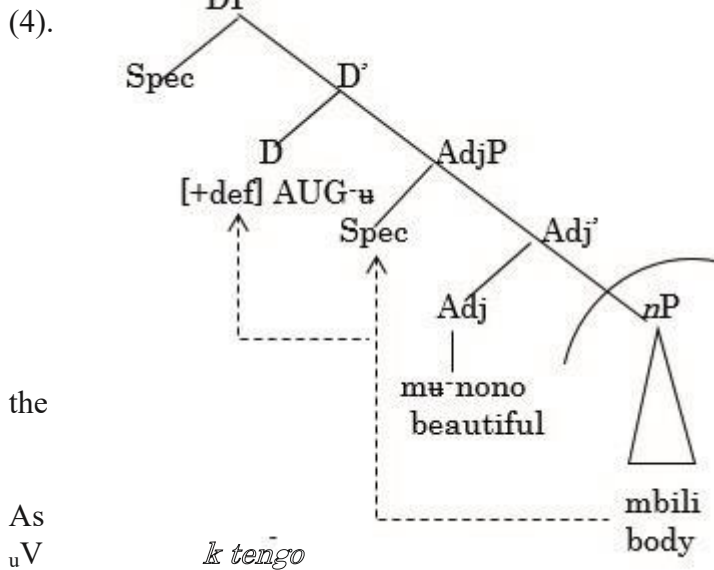

the  
 As  
 uV

Example (4) above the Agree head merged (AgreeP) which is between the D and N hosts agreement features ( $\phi$ -features) gender and number linked to the nouns. At the level of phonology, the augment (D) is an empty vowel syllable linked to extended projection principle (EPP) uninterpretable ( $uV$ ) feature. This (phonetically) empty position, depending on parametric specifications selected by the language, may remain empty or be partially or fully realized as an epenthetic or copied vowel. such, a case in (2a-c) may be represented as [DP [GendP CV [NP]]]. As it can be seen in (2), the noun class prefix, (also Gender morpheme

(Ndayiragije, et. al., 2012)), consists of a consonant and a vowel (CV). In this case, the CV template, is fully specified (interpretable) and the augment which is the determiner, is unspecified, hence, uninterpretable at PF. This suggests that the derivation of a noun such as *ikitengo* ‘chair’ will be represented as follows.

(5). i-ki-tengo  
 AUG-Cl6-chair  
 ‘the chair’

[DP  $\bar{V}$  [GendP CV [NP]]] → [DP  $\bar{V}$  [GendP CV [NP]]]  
 /ø- ki- tengu / → /i- ki- tengu /

Example (5) above accounts for the fact that the augment copies the features of the vowel in the noun class prefix as the result of agreement between the vowels in the noun class prefix and the determiner. An argument can be made that the augment in Kibhwanbi language is the syntactic head of the determiner phrase structure.

**A Prenominal Possessive –nya as a Determiner**

Kibhwanbi language presents two types of possessives. The post nominal possessives and the pre nominal possessives. In this section, I present the pre nominal possessivemarked by the formative –nya. The possessive as a modifier of a noun in Kibhwanbi language is canonically at the post nominal position. However, there is a case where the possessive marker –nya inhabits the position before the noun yielding a

second type of possessive we have labeled a 'pre-nominal possessive'. Semantically, the formative *-nya* expresses the idea of 'the owner of,' or 'containing'.

This form consists of the augment of the noun class of the possessor plus the possessum. Consider the following examples:

(6). (a) *#n-nyam#-gh#ndaj#laakansuung 'hakange#-nkami#-j#nge*. AUG-cl1-owner cl18-field DEM 3SG-send-PAST againAUG-cl1-servant

"That owner of the field sent again another servant."

(b) *i-supai-nyamafuta a-ma-n-ofu a-gh-a ndalamany-inga UG-cl9-bootle AUG-owner cl6-oil AUG-cl6-good AUG-cl6ASS cl9-money cl9-many* 'the bottle full of good, expensive oil.'

Examples (6a-b) above show that, as is the case with genitive constructions, the first constituent of the possessum does not have the augment. Instead, the augment is realized in the *-nya* formative. In this case, the following will be the morphological structure of the noun containing the formative *-nya* which marks possession in different noun classes as shown in the following table:

**Table 2: Morphological Structure of Kibhwanji Nouns Preceded by -NYA**

| NCL | AUG | CLASS PREFIX | STRUCTURE         | GLOSS                     |
|-----|-----|--------------|-------------------|---------------------------|
| 1   | u   | (a- /m#-)    | u#n-nya mwana     | 'the owner of the child'  |
| 2   | a   | bha-         | a-bha-nya mwana   | 'the owners of the child' |
| 3   | u   | m#-          | u-bh#langali      | 'consisting of redish'    |
| 4   | i   | mi-          | i-gh#-nya mipembe | 'consisting of horns'     |
| 5   | i   | li-          | i-li-nya ng'aki   | 'owner of thirst'         |
| 6   | a   | ma-          | a-gh#-nya bhana   | 'owners of children'      |
| 7   | i   | ki-          | i-ki-nya kyaka    | 'consisting of handle'    |
| 8   | i   | fi-          | i-fi-nya kyaka    | 'consisting of handle'    |
| 9   | i   | ji-          | i-ji-nya mbunda   | 'containing club'         |
| 10  | i   | si-          | i-si-nya mbunda   | 'containing clubs'        |
| 11  | u   | lu-          | u-lu-nya luhala   | 'with brains'             |
| 12  | a   | ka-          | a-ka-nya mbeda    | 'with disrespect'         |
| 13  | u   | tu-          | u-tu-nya mbeda    | 'with disrespect'         |
| 14  | u   | bhu-         | u-bhu-nya mabuje  | 'with bolls'              |
| 15  | ∅   | ku-          | ∅-ku-nya bhaanhu  | 'containing people'       |
| 16  | ∅   | pa-          | ∅-pa-nya bhaanhu  | 'with people'             |
| 17  | ∅   | ku-          | ∅-ku-nya bhaanhu  | 'containing people'       |
| 18  | ∅   | m#-          | ∅-m#-nya malenga  | 'containing water'        |
| 19  | ∅   | -ji-         | ∅-ji-nya lukwale  | 'with craziness'          |

Table 2 above shows that the root of the prenominal possessive determiner *-nya* occurs consistently with all noun classes including locative classes 16, 17, and 18. It does not change its form nor its position relative to the noun. As such the phrase structure of the noun containing the pre nominal possessive determiner will be as follows:

(7). *#n-nyamwana*

AUG-owner of cl1-child  
'owner of a child'

(8).

The tree formative – augment the noun *-nya* category, as a augment is determiner augment. kind of

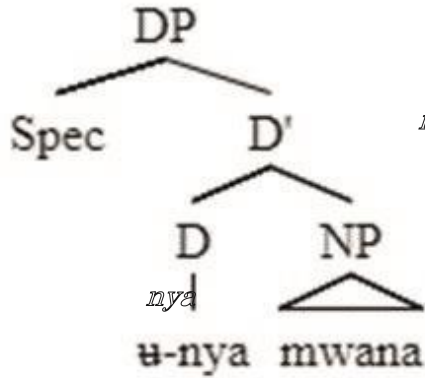

structure in (8) above indicates that when the *nya* is used to indicate possession. It deletes the *mwana* that was primarily supposed to be accompanied with *mwana*. This means the formative *-nya* is a special which functions as a determiner. It is base generated determiner since it appears within the slot where the found. For that case, the prenominal possessive *-nya* is in complementary distribution with the *mwana*. Moreover, the formative *-nya* does not undergo any movement because it is restricted to occur pre-nominally with its head noun where it functions as a determiner specifying the range of reference of the noun.

**Pre-nominal Demonstratives as a ‘Determiner’**

Data of Kibhwanbi language show that the language posits two types of demonstratives, namely prenominal demonstratives and post nominal demonstratives. This is equivalent to majority Bantu languages such as Kiswahili (de Velde, 2005 and Ndomba, 2017). On one hand post nominal demonstratives occur at the post nominal slot in Kibhwanbi DP performing a deictic function by showing relative location or distance of the referred entity in relation to the participants taking part in contextual discourse. Consider the following examples:

(9). (a) I-ng<sup>h</sup>uku                      isi                      sili n<sup>h</sup>amu  
 AUG-chicken      DEM-these      are      sick  
 ‘these chicken are sick’

(b) A-bha-nu                      bhoni abhuo                      bhikimbila  
 AUG-cl1-people cl1-all      DEM-those are  
 running  
 ‘All those people are running’

In example (9) (a-b) the demonstratives *isi* ‘these’ and *abhuo* ‘those’ play a deictic role of pointing at the location of *ing<sup>h</sup>uku* ‘chicken and *abhanhu* ‘people’. The phrase structure for the DP containing post nominal demonstrative is as follows:

(10).

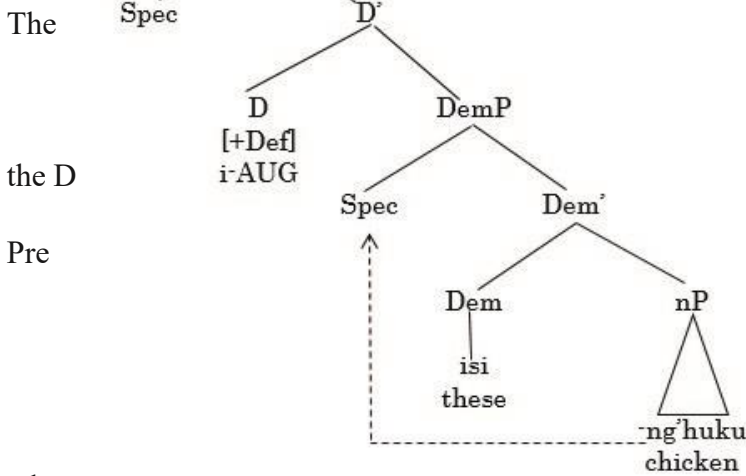

structure in (10) above shows that the augment *i-* occupies the D slot which is specified for definite article. On the other hand, the demonstrative *isi* ‘these’ is below and functions as a deictic marker.

nominal demonstratives pose certain affects pertaining to the meaning of the DP. In this study, I argue that, pronominal demonstratives, in Kibhwanbilanguage function as the definite article. This observation is in line with de Velde (2005) clearly points out that the pronominal

who demonstrative is used as the definite article in some Bantu languages like Swahili. When it occurs pre nominally position, it expresses the emphatic interpretation. Consider the following conversation between speaker A and B.:

(11). A *i-ki-nu ki-kiki-no wi-koola?*

AUG-cl7-thing cl7-what cl7-REL SM-crying  
‘what are you crying for?’

B *I-jing’ukun-debe. Ji-fuile.*

DEM cl9-hen cl9-small cl9-die-PAST  
“This [SPECIFIC] small hen has died.”

In example (11) above, between conversation A and B, the demonstratives  $\bar{\text{T}}\text{-ji}$  ‘this’ in B occurs at the pre-nominal position. The discourse reading of this utterance is that, both A and B have a pre conceived knowledge that there is more than one hen. Therefore, the use of demonstrative *i-ji* ‘this’ in *I-jing’ukun n-debe. Ji-fuile.* “This [SPECIFIC] small hen has died.” expresses the particularization of the specific hen which has died among many other hens which are implicitly known to be existing in the conversational discourse. Furthermore, the use of the pre-nominal demonstrative *i-ji* ‘this’ in this context entails an anaphoric reading in that the referent is now familiar to the discourse participants, hence expressing specificity and definiteness interpretation.

In terms of syntactic position, the pronominal demonstrative and augment are in complementary distribution. The presence of a pronominal demonstrative deletes the augment. Consider the following examples:

- (12). (a) *ughu m-piki ghwa nkota*  
DEM-this cl3-tree ass- of cl3medicine  
‘this tree of medicine’
- (b) *\*ughu u-m-piki ghwa nkota*  
DEM-this AUG-cl3-tree ass-of cl3-medicine  
‘this the tree of medicine’

In example 12(a), it can be observed that the pre nominal demonstrative *ughu* ‘this’ deletes the augment in the noun *mpiki* ‘tree’. In this case, the pronominal demonstrative *ughu* ‘this’ occupies the D position that was supposed to be occupied by the augment. By occupying the D slot, the pronominal demonstrative functions as a definite article and not as a deictic marker as in (8) above. Therefore, the pronominal demonstrative appears to have been raised from its original (base generated) position below D. Based on this view, the

following would be the phrase structure of the DP containing pronominal demonstrative for the phrase *#ghumpiki#ghwankota* 'this of medicine'.

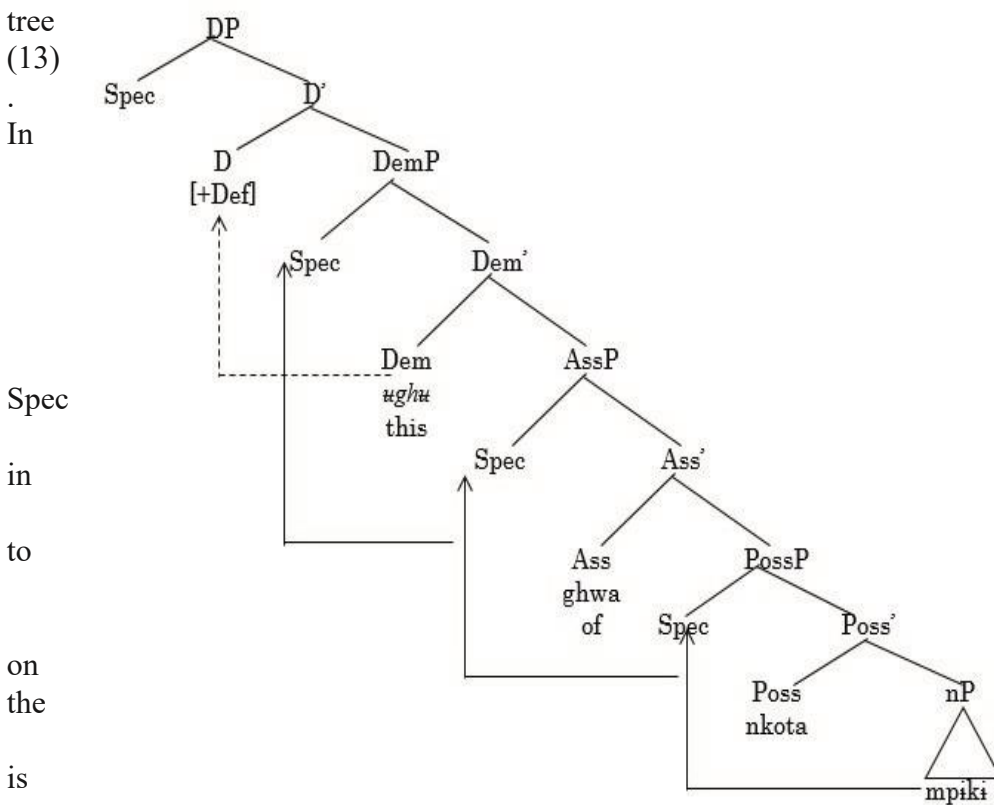

example (13) above, due to definiteness feature, the pronominal demonstrative *ghu* 'this' is raised obligatorily to the determiner position. As such, the rising of the nP to DP is constrained and consequently the nP resides Spec DemP. Moreover, the rising of the demonstrative the D position marking definiteness preempts the application of an augment the noun. This means that definiteness function performed by the augment now assumed by the demonstrative.

Order of Modifiers in the Kibhwanji Determiner Phrase

Kibhwanbi Determiner Phrase structure may range from a minimum of one modifier, to a series of several modifiers. The modifiers include demonstratives, Possessives, quantifiers, adjectives, numerals, and relative clauses. Consider the data in the following table:

Table 3: Kibhwanji DP Template

| Determiners/Distributives |     |       |      | Head | Modifiers |    |     |     |     |     |    |     |
|---------------------------|-----|-------|------|------|-----------|----|-----|-----|-----|-----|----|-----|
|                           |     |       |      | Noun | 1.        | 2. | 3.  | 4.  | 5.  | 6.  | 7. |     |
|                           |     |       |      |      |           |    | Dem | Num |     |     |    | Rel |
| Dem                       | Aug |       |      |      |           |    |     |     |     |     |    |     |
|                           |     |       |      | Poss |           |    |     |     | Adj |     |    |     |
|                           |     |       |      |      | Quant     |    |     |     |     | Ass |    |     |
|                           |     | Distr |      |      |           |    |     |     |     |     |    |     |
|                           |     |       | Poss |      |           |    |     |     |     |     |    |     |

Source: Researcher, 2022

A DP with a Noun and a Pronominal Demonstrative

-A DP with a Noun and a Pronominal Demonstrative

In the structure of a DP made of a noun and demonstrative, normally, the demonstrative proceeds the noun. This yields the Noun>Demonstrative (N>Dem) order. As demonstrated in the following examples:

- (14). (a) A-bha-anhu                      bha-la  
 AUG-cl2-people                      cl2-Dem

‘those people’

- (b) *i-fi-ghono*                      *i-fi-o*  
 AUG-cl8-time AUG-cl8-Dem  
 ‘those times’

Example 9 above shows that when the DP is made up of a demonstrative and noun, the noun precedes the demonstrative. This typical order of noun>demonstrative modification agrees with with majority Bantu languages such as Kagulu (Petzell, 2008), (Nyakyusa (Lusekelo, 2009), Swahili (Ndomba, 2017), to mention but a few. However, there are possibilities, though not typical, for a demonstrative to precede the noun. Consider the following examples:

- (15). (a) *#-j#*                      *m#-ghoosi kyang’aani*  
 AUG-Dem      cl1-man              For sure  
 ‘for sure this is a man’  
 (b) *j#-la m#-kij#bha ijile*      cl1-Dem cl1-lady has come  
 ‘that lady has come’

Example 15 demonstrates the case where a demonstrative precedes the noun. As already established elsewhere, when the demonstrative precedes the noun it encodes emphasis. In this case, the demonstratives do not serve the deictic function but behaves as the determiner. This observation is similar to other Bantu languages like igiHa. According to Bichwa (2021), the appearance of demonstratives in the prenominal position in igiHA language assumes a referential function. In this case, it points back to an entity that has been mentioned earlier in a preceding discourse. Thus, prenominal demonstratives serve an anaphoric function.

#### A DP with a Noun, Possessive and Demonstrative

Kibhwanbi presents a case where there could be a DP made of a noun demonstrative and a possessive. In this case, it is a post nominal possessive being addressed and its order is Noun > Possessive > Demonstrative (N>Poss>Dem). The case in point is exemplified as follows:

- (16). (a) *i-nyumba*                      *j-angu*                      *ji-la*  
 AUG-house                      cl9-my cl9-Dem  
 ‘that house of mine’  
 (b) *i-ki-maghe*                      *ki-la*                      *ky-ango*  
 AUG-cl7-knife                      cl7-Dem                      cl7-mine  
 ‘that knife of mine’

One can see that in 16 (a) the demonstrative is set to appear just after the possessive making the Poss>Dem order. This shows that when a possessive is added to the DP in Kibhwanbi, the possessive precedes the demonstrative. On the other hand, it is possible to have the demonstrative precedes the possessive for the same reason as in (16) above as it is shown in 16 (b). Speakers of Kibhwanbi acknowledged that it is possible to make the possessive come after the demonstrative when one wants to make the referent specific or when you want to mark emphasis.

#### A DP with a Noun, Possessive, Demonstrative and Quantifier

Canonically, the quantifier follows the possessive. This yields the Noun > Possessive > quantifier > demonstrative (N>Poss>Quant>Dem) order. Unlike numerals, which show the actual number of the head being referred, quantifiers do not show actual number of the noun they modify. Instead, they denote how many things a given statement is referring to in ‘generals’ (Anderson 1973). Kibhwanbi language attests for three quantifiers -oni ‘all/both/whole’, -inga ‘many’, -debe ‘few/some’. Consider the following examples:

- (17). (a) *#-#-pene twa-ango tw-oni*                      *tu-la*

- AUG-cl13-goat      cl13-Poss      cl13-all      cl13-Dem  
 ‘all those small goats of mine’
- (b) a – bha -anhu      bha-ake      bh –inga      bha-la  
 AUG-cl2-people      cl2-Poss      cl2 –many      cl2-Dem  
 ‘those many many people of him/her’
- (c) A-bha-na      bha-ake      bha-debe bha-la  
 AUG-cl2-children      cl2-Poss      cl2-few cl2-Dem  
 ‘those few children of him/her’

In example (17), the quantifiers appear post-nominally. According to the respondents, any attempt to prepose the quantifiers would lead to ungrammatical constructions. In 17 (b) the quantifier inga ‘many’ is used without the augment. The augmented form is only used when a comparison is implied as in the following cases:

- (18). (a) A-ma-aka      m-inga gha-kilil-e.  
 AUG-cl6-year      cl6-many      cl6:go.by.:PF

“Many years went by.”

- (b). A-ma-aka a-m-inga gha-kilil-e, gha-sighiil-e madebe.

AUG-Cl6-year AUG-cl6-manycl6-go.by-PAST cl6-be. left-  
 PRS cl6-few

“Many years went by, a few are left.”

Examples in 18 (a-b) above show that the use of an augment marks specificity. While it is not possible to constitute a [±SPEC] contrast in the noun by the means of (not) using the augment in DPs that begin with a noun, it is possible for this quantifier. When using ‘many’ with the augment, it refers to an identified, i.e. specific group of entities. This does not hold true for contexts in which the quantifier is used without the augment.

#### **A DP with a Noun, Possessive, Quantifier, Demonstrative and Numeral**

When numerals are added to a DP containing demonstrative, they follow the demonstrative. In this section, I treat numerals as separate modifiers (not belonging to the group of quantifiers) because they occupy a different slot in the syntax of the DP and can co-occur with the quantifiers in a single DP as exemplified in the following:

- (19). a-bha-ana bha-ango bho-oni      bha-la bha-bhili  
 AUG-cl2-child cl2-Poss      cl2-all      cl2-Dem      cl2-two  
 ‘all those two children of mine’

Example 14 above shows that the quantifier bhooni ‘all’ can occur with the numeral bhabhili ‘two’ in a single DP. When the demonstrative is introduced in the DP, it splits the general quantifier bhnooni ‘all’ and the numeral bhili ‘two’. Thus, they occupy different slots in the DP structure with the numeral occupying the position after demonstrative, hence the resultant structure is N>Poss>Quant>Dem>Num. The structural derivation of this DP would be as follows:

(20)

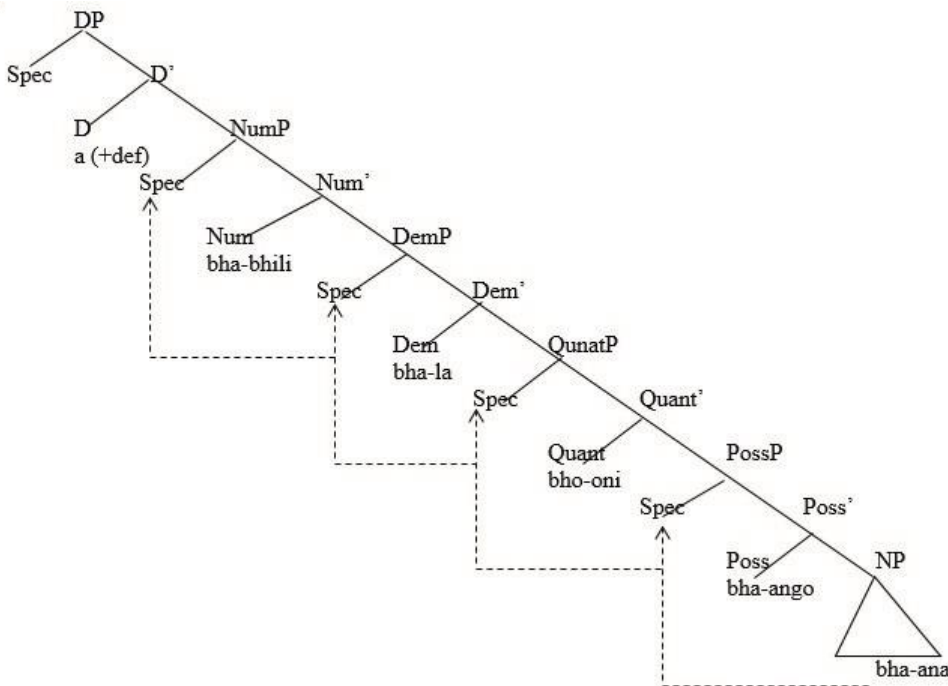

The structure in (20) above illustrates how the nPbhaana ‘children’ undergoes a cyclic movement from its underlying position, through Spec Poss, SpecQuant, SpecDem and rests at the SpecNum where it occupies its position for the DP order to be correct.

**A DP with a Noun, Possessive, Quantifier, Demonstrative, Numeral and Adjective**

When an adjective is piled up to the DP containing Possessive, Quantifier, Demonstrative, and Numeral, it is preceded by numerals. As such, the resulting order of the modifier will be N>Poss>Quant>Dem>Num>Adj. However, it is worth noting that adjectives can be handled in two ways. First, as elements which are hosted by various functional categories (Cinque1993; Crism, 1993). Second, as adjuncts of the NP (Alexiadou 2001; Radford, 2004). Consider the following examples. In this paper, I use the second approach and consider the adjective as an adjunct of the NP. This option follows the argument that when they are handled as adjuncts they do not interrupt the movement within the DP during nP rising (Rizzi, 1990; Alexiadou, 2001).

(21).(a) *i-fi-maghe fy-angofyoni fi-l-a fi-bhili fi-nono*

AUG-cl8-knives cl8-Poss cl8-Quant cl8-Dem cl8-two cl8-good ‘all those two beautiful knives of mine’

(b) *a-bhabh#lan#i#si#bh#abha-ake bha-bhili bhanono*

AUG-cl2-teacher cl2-Poss cl2-two cl2-good

‘the two good teachers of him/her’

The phrase structure for the DPs above would be as follows:

(22).

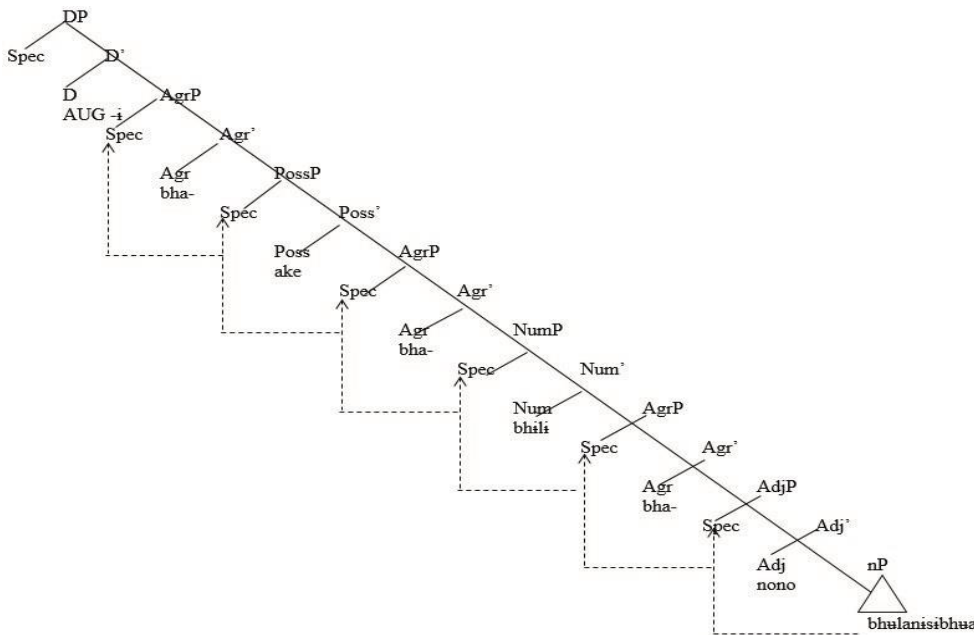

The structure in (22) above presents the fact that an adjective nono ‘good’ is generated as an adjunct of the nPbhabhulani**sibhua** ‘teachers. The noun (nP) moves cyclically to various specifier positions while checking its agreement features and lands to the SpecAgr.

**A DP with a Noun, Possessive, Quantifier, Demonstrative, Numeral and Relative Clause**

In Kibhwanbi language, a possible DP may contain up to seven modifiers. The relative clause is the right most element in structure.

Kibhwanbi marks relative clause overtly by using a relative pronoun root –no ‘who, which, with which’. This can be presented in the following table:

**Table 4: Relative Clauses Markers in Kibhwanji**

| NCL | AUG | CL-PREFIX | STEM    | EXAMPLES  | GLOSS      | REL               |
|-----|-----|-----------|---------|-----------|------------|-------------------|
| 1   | u   | (a- /mu-) | -hinja  | uməhinja  | ‘lady’     | ju <sub>no</sub>  |
| 2   | a   | bha-      | -ana    | abhana    | ‘children’ | bha <sub>no</sub> |
| 3   | u   | mu-       | -enda   | umwenda   | ‘cloth’    | ghu <sub>no</sub> |
| 4   | i   | mi-       | -enda   | imyenda   | ‘clothes’  | ghin <sub>o</sub> |
| 5   | i   | li-       | -bhue   | ilibhue   | ‘stone’    | lin <sub>o</sub>  |
| 6   | a   | ma-       | -bhue   | amabhue   | ‘stones’   | gha <sub>no</sub> |
| 7   | i   | ki-       | -tengo  | ikitengo  | ‘chair’    | kin <sub>o</sub>  |
| 8   | i   | fi-       | -tengo  | ifitengo  | ‘chairs’   | fin <sub>o</sub>  |
| 9   | i   | ni-       | -bunda  | imbunda   | ‘club’     | jin <sub>o</sub>  |
| 10  | i   | ni-       | -bunda  | imbunda   | ‘clubs’    | sino              |
| 11  | u   | lu-       | -mili   | ulumili   | ‘tongue’   | lu <sub>no</sub>  |
| 12  | a   | ka-       | -pene   | akapene   | ‘goat’     | kano              |
| 13  | u   | tu-       | -pene   | utupene   | ‘goats’    | tano              |
| 14  | u   | bhu-      | -ghale  | ubhughale | ‘meal’     | bhu <sub>no</sub> |
| 15  | o   | ku-       | -ghenda | kughenda  | ‘walking’  | ku <sub>no</sub>  |
| 16  | o   | pa-       | -kaja   | pakaja    | ‘home’     | pano              |
| 17  | o   | ku-       | -nyumba | kunyumba  | ‘house’    | ku <sub>no</sub>  |
| 18  | o   | mu-       | -kate   | munkate   | ‘inside’   | muno              |
| 20  | o   | -gha-     | -temo   | ughutemo  | ‘axe’      | ghu <sub>no</sub> |

Source: Researcher, 2022

In table (23) above, the relative pronoun root *-no* takes the shape of the noun class prefix of the head noun the relative clause is modifying. The following examples illustrate this.

(24). (a) *A – ma - lengagha - no ghi-ghendagha - li hatali* AUG-C16-water C16-RELSC-run SC-be dangerous  
 ‘The water which can be dangerous’

(b) *I-*f*-tengo *f*-debe*f*no*f*idenyike*f*itagh-ilwe*  
 AUG-cl8-chairscl8-fewC18-REL SM-bkokenSC-throw-PF  
 ‘few chairs which are broken have been thrown’

In examples (24) above, the relative markers *ghano* ‘which’ and *fino* ‘which’ are marked outside the verbal structure. This contrasts languages like Runyambo (Neckemia, 2019), Runyankore-Rukinga (Asiimwe, (2019), and Swahili (Ndomba, 2017) in which the relative markers may be part of the verb complex. Moreover, syntactically, relativized DPs are derived through the movement of head nouns (nP) from their base generated position to Spec DP. The case in point can be presented in the following structure-using example (25b). (26)

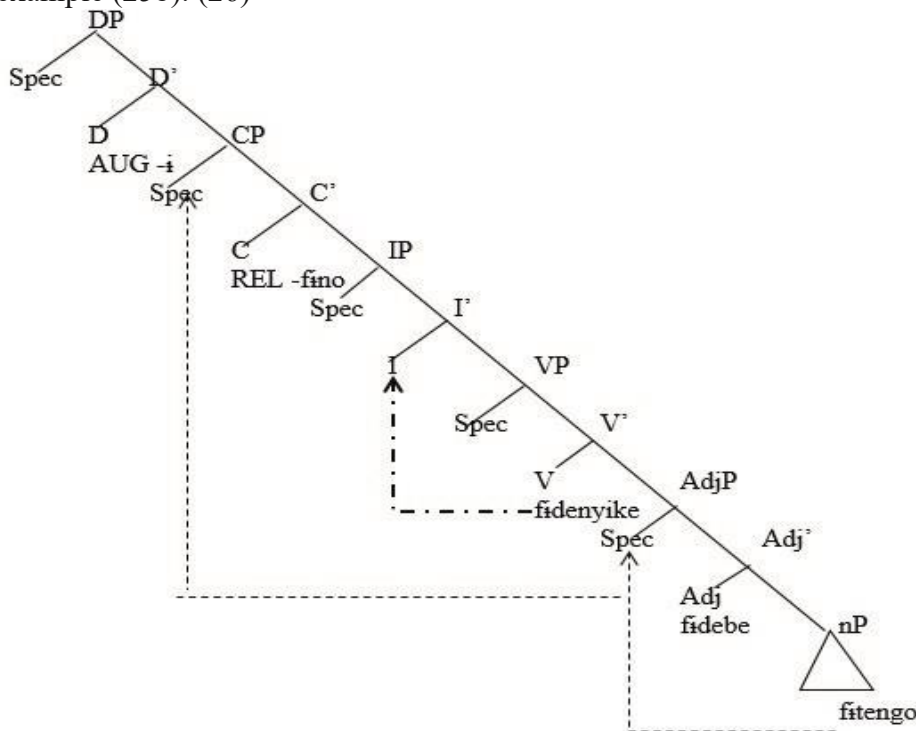

In (27), the relative word *fino* ‘which’ is generated under the complementiser ‘C’ which hosts abstract relative feature (+REL).

Meanwhile, the relativized DP *f*itengofidebe*f*no*f*idenyike ‘the small chairs which are broken’ is derived from the movement of the nP *f*itengo ‘chairs’ from its default position to SpecCP though SpecAdj is generated under C hosting [+REL] abstract features. The nP does not rise further to SpecDP because the D is already occupied by an augment which stands as a functional category heading the DP. In the same structure, there is the movement of the verb *f*idenyike ‘have broken’ to I in order to bestow to its tense features. When other modifiers are added to the DP containing relative clauses, the movement takes place in the same usual fashion in order to achieve a correct word order.

**Summary and Conclusions**

The study has pursued the Structure of Kibhwanbi Determiner Phrase. The focus has been on establishing the functional categories which head the DP and to examine the order of modifiers within the Kibhwanbi DP. It has been established that Kibhwanbi language uses augments, the pronominal possessive formative *-nya*, and

prenominal demonstratives as functional categories which realize the D. The augment and the formative – nya are not subjected to any movement because they are restricted to occur pre-nominally with their head noun where they function determiners specifying the range of reference of the noun. On the other hand, demonstratives which are, canonically, post nominal may appear post nominally where they function as English definite article the. Therefore, syntactically prenominal demonstrative appears to have been raised from its original (base generated) position below D. This paper has also pursued the order of modifier in Kibhwanbi Determiner Phrase and how it is derived from the underlying structure through principles of movement. It has been noted that, modifiers in Kibhwanbi Determiner Phrase may range from a minimum of one to six. This yields the order (DEM)/(AUG)/(DISTR)/(POSS)>N>POSS>QUANT>DEM>NUM>ADJ>REL. However, the order of these modifiers is not rigid. For encoding emphasis or focus to some modifiers the order may change, thus making the order.

#### **Declaration of conflicting interests**

The author(s) declared no conflict of interest(s) with respect to the research, authorship and/or publication of this paper.

#### **Funding**

The author(s) declared that he received financial support for the research from Dar es Salaam University College of Education.

#### **References**

- Abney, S. (1987). *The English Noun Phrase in its Sentential Aspect*. PhD Dissertation, Massachusetts Institute of Technology, Massachusetts: MIT Press.
- Alexiadou, A., Haegeman, L. & Stravrou, M. (2007). *Noun Phrase in the Generative Perspective*. New York: Berlin Mouton de Gruyter.
- Baswet, et al. (2014). The Ekegusii Determiner Phrase Analysis in the Minimalist Program. *International Journal of Linguistics and Communication*, 2(3). DOI: 10.15640/illc/xxxxxx.
- Bernstein, J. B. (2001). The DP Hypothesis: Identifying Clausal Properties in the Nominal Domain. In M. Baltin & C. Collins (Eds.). *The Handbook of Contemporary Syntactic Theory*, 536– 561). Massachusetts.
- Bichwa, S. S. (2021). *The Determiner Phrase Syntax of Igiha: A generative Approach*. Unpublished PhD Dissertation, Stellenbosch University.
- Borer, H. (2005). *Structuring Sense: An Exo-skeletal Trilogy*. Oxford: Oxford University Press.
- Carstens, V. (1991). *The Morphology and Syntax of Determiner Phrases in Kiswahili*. Unpublished PhD Dissertation, Los Angeles, University of California.
- Carstens, V. (2008). The Structure of DPs: DP in Bantu and Romance. In C. De Cat & D. Catherine (Eds.). *The Bantu-Romance*
- Connection: A Comparative Investigation of Verbal Agreement, DPs, and Information Structure, 131. Amsterdam: John Benjamins B.V: 131–166.
- Chomsky, N. (1995). *The Minimalist Program*. *Current Studies in Linguistics*, 28. Cambridge, MA: MIT Press.

- Chomsky, N. (2000). Minimalist Inquiries: The Framework. In R. Martin, D. Michaels & J. Uigereka (Eds.). *Step by Step: Essays on Minimalist Syntax in Honour of Howard Lasnik*, 89–115. Cambridge, MA: MIT Press.
- Cinque, G. (2005). Deriving Greenberg's Universal 20 and its Exceptions. *Linguistic Inquiry*, 3, 315–332.
- Fischer, H. (2011). *The Augment in Vwanji (G66)*. Unpublished Master's Dissertation, Hamburg University.
- Giusti, G. (2015). *Nominal Syntax at the Interfaces: A Comparative Analysis of Languages with Articles*. Cambridge: Cambridge Scholars Publishing.
- Lyons, C. (1999). *Definiteness*. Cambridge University Press.
- Mose, G. E. (2012). *The Structure and Role of Determiner Phrase in Ekegusii: A Minimalist Approach*. Unpublished M.A. Thesis, Kenyatta University.
- Ndomba, R. G. (2017a). *The Structure and Derivation of the Determiner Phrase in Swahili*. Unpublished PhD (Linguistics) Thesis, University College Dublin.
- Nurse, D. (1988). The Diachronic Background to the Language Communities of Southwestern Tanzania. *Sprache und Geschichte in Afrika*, 9: 15–115.
- Nweze, I. M. (2014). Determiner Phrase in the Igbo Language: *International Journal of Social Sciences and Humanities Reviews*, 4(4): 94–107.
- Payne, T. E. (2006). *Exploring Language Structure: A Student's Guide*. Cambridge: Cambridge University Press.
- Radford, A. (2009). *An Introduction to English Sentence Structure*. Cambridge: Cambridge University Press.
- Simile, O. (2013). *Phonological Aspects of Kibwanbi*. Unpublished M.A. Dissertation, University of Dar es Salaam.
- Simile, O. & Upor, R. A. (2017). Segmental Aspects of Kibwanbi Phonology: A Non-Linear Representation. *Utafiti Journal*, 12(1 & 2).
- Sulemana, A. R. (2012). *The Structure of the Determiner Phrase in Buli*. Unpublished M.Phil Thesis, University Lagos.
- Visser, M. (2008). Definiteness and Specificity in the IsiXhosa Determiner Phrase. *South African Journal of African Languages*, 28(1): 11–29. DOI: <https://doi.org/10.1080/02572117.2008.10587298>
- Zamparelli, R. (2000). *Layers in the Determiner Phrase*. University of Rochester.