

# IOT-ENABLED RFID SMART PARKING SYSTEM WITH AUTOMATED BILLING AND REAL-TIME SLOT MANAGEMENT

Ella Srividya<sup>1</sup>, Y. Vasantha<sup>1</sup>, L. Ramesh<sup>1</sup>

<sup>1</sup>Department of Electronics and Communication Engineering  
Sree Dattha Institute of Engineering and Science, Sheriguda, Hyderabad, Telangana

## ABSTRACT

Car parking is a significant challenge in malls and cities, requiring an efficient and smart management system. Our project introduces a smart parking system that utilizes the Internet of Things (IoT) to automate parking slot allocation. The system employs IR obstacle sensors to detect vehicle presence, which are connected to an Arduino microcontroller. Three IR sensors monitor three parking positions, and the corresponding data is displayed on an LCD screen and an IoT app. Users can check slot availability in real time. To enhance security, the system incorporates RFID-based vehicle access control. Only valid vehicles are permitted to proceed with parking fee payment, after which a servo motor opens the gate, allowing entry. Once inside, the vehicle is assigned a parking slot, and the updated slot information is posted to an IoT server. The microcontroller continuously updates the status of all IR sensors, displaying available slots on LCD modules and the IoT app, enabling easy access to parking data. A Wi-Fi module (ESP8266) facilitates real-time data transmission, allowing users at the parking facility to view empty slots. Additionally, a GSM module sends transaction details via SMS and can process requests to locate available parking spaces. By integrating IoT, this system reduces parking congestion, minimizes waiting times, and ensures the efficient use of parking spaces. Implemented using embedded C programming, this smart parking solution offers a seamless and intelligent approach to urban parking management, enhancing convenience and optimizing space utilization.

**Keywords:** RFID, Smart Vehicle Parking, Automated Billing, Iot, IR Sensor, Arduino Microcontroller, LCD Display, Servo Motor, Security, Internet Of Things, Wifi Module (ESP8266), GSM

## 1. INTRODUCTION

Modern cities face significant parking challenges due to increasing vehicle numbers and limited parking spaces, necessitating efficient management systems. Our IoT-based smart parking system optimizes space utilization using IoT technology. It employs IR sensors to detect parking slot occupancy and DC motors to simulate gate operations. An AVR microcontroller manages the system, while a Wi-Fi modem ensures seamless internet connectivity. The system integrates with IoT Gecko for online connectivity and GUI-based IoT management, enabling real-time monitoring and efficient parking allocation. This innovative approach enhances convenience, reduces congestion, and streamlines parking operations. The system detects if parking slots are occupied using IR sensors. Also, it uses IR technology to sense if a vehicle has arrived on gate for automated gate opening. The system reads the number of parking slots available and updates data with the cloud server to allow for checking parking slot availability online. This allows users to check for available parking spaces online from anywhere and avail hassle-free parking. Thus, the system solves the parking issue for cities and gets users an efficient IOT-based parking management system. In recent times, the concept of smart cities has gained popularity. Thanks to the evolution of the Internet of Things, the idea of smart cities now seems to be achievable. Consistent efforts are being made in the field of IoT in order to maximize the productivity and reliability of urban infrastructure. Problems such as traffic congestion, limited car parking facilities, and road safety are being addressed by IoT. In this paper, we present an IoT-based cloud-integrated smart parking system. The proposed Smart Parking system

consists of an on-site deployment of an IoT module that is used to monitor and signalize the state of availability of each single parking space. A mobile application is also provided that allows an end user to check the availability of parking space and book a parking slot accordingly. The paper also describes a high-level view of the system architecture. Towards the end, the paper discusses the working of the system in form of a use case that proves the correctness of the proposed model. The concept of Internet of Things (IoT) started with things with identity communication devices. The devices could be tracked, controlled or monitored using remote computers connected through Internet. IoT extends the use of Internet providing the communication, and thus inter-network of the devices and physical objects, or 'Things'

## 2. LITERATURE SURVEY

[1] The sensors used in IoT based smart parking systems store and access data from remote locations with the help of the cloud. These factors give rise to cloud of things (COT). The nodes could be monitored and controlled from any location. The system that we propose provides information regarding the availability of the parking slots with the help of the mobile application. The users from the remote location can book the parking slots. [2] An algorithm is used to increase efficiency of cloud-based parking system and network architecture technology is used. This algorithm is used to find the lowest cost parking space. Considering the number of parking space available and also considering the distance of the parking space from the user. The user can directly access the cloud-based server and find the information on the parking space. The user can also install an application in their mobile phones to access this information. With the help of this algorithm, waiting time of the user to find a parking space can be minimized. Security aspects are not included in this paper. [3] A wireless sensor node along with smart phone application is being used to find the parking space. Since, wireless technology is used here the system has high accuracy and efficiency. In this system, onboard units are used to communicate with other vehicles. The user parks his vehicle in any one of these several bays available and a mechanical lift lifts the vehicle out. A ticket key and id are given to the user and it is only known to the user which is used to retrieve the vehicle. The user need not carry any paper ticket since an Rfid card is given to the user. The technology used here is economical. Security features must be improved to protect the user's privacy. [4] The author of smart parking system survey has divided detector system and vehicle sensors into two categories as intrusive sensors and non-intrusive sensors. Intrusive sensors are installed in holes on the road surface by tunnelling under the road. Non-intrusive sensors do not affect the surface of the road and it can be easily installed and maintained. Smart parking system helps to solve the grounding problems of the traffic congestion and it also reduces the emission from a car. [5] A paper proposes efficient way to unfold the issue of parking availability in the real time scenario and to reduce the time consumption. In this, the data is sent locally with devices which filters the data. This signal is transmitted over the cloud for the process as well as for evaluation which uses machine learning algorithms. This paper uses mobile phone application that connects the user with the real time traffic status via Google API. Thus, avoiding traffic congestion. This paper does not provide the reservation facility for the car parking. [6] Smart parking using IoT technology helps to design and develop a real smart parking system which provides information for vacant spaces and also helps the user to locate the nearest availability. This paper uses a computer vision to detect vehicle number plate in order to enhance the security. The user can pay for the parking space prior to the entry of the car through mobile payment. Thus, insuring the reservation of the parking. The user is notified about the parking location, number of slots available and all other relevant information. The paper uses efficient algorithms and techniques for extracting license plate text. An algorithm operates on the ultrasonic sensor detection of the vehicle entering into the parking slot and calculates the minimum cost for the user. [7] Smart parking system based on reservation allows the reservation of a vacant space which involves smart parking system based on reservation (SPSR). This consists of host parking database management which collects and stores data about the driver's identity and parking location. When the parking reservation time is about to expire a notification will be sent to the user through the web service that has been provided to the user by the admin. The

main drawback is that some other user can occupy a reserved parking space to avoid this QR scanners are used to identify the user.

**4. PROPOSED SYSTEM**

The proposed system is used to indicate the user about the vacancy of the parking slots. A user can choose the parking slot in advance, instead of waiting in a area of the parking, where the parking availability is shown through user's smart phones. RFID reader and card will provide the security of the parking system. IR Sensors will be attached in each slot for detecting the vacancy. The signal from the sensors captured by Arduino and this signal is then converted from electrical signal into another form to detect presence of vehicle in terms of the amount of light reflected back from the obstacle such as wall of the parking lot. The output from Arduino depends on the measurement of amount of light and based on that, slot's allocation is done. On the other hand, the output from Arduino is changed into text format and sent to the smart phones through a developed Android IOT application.

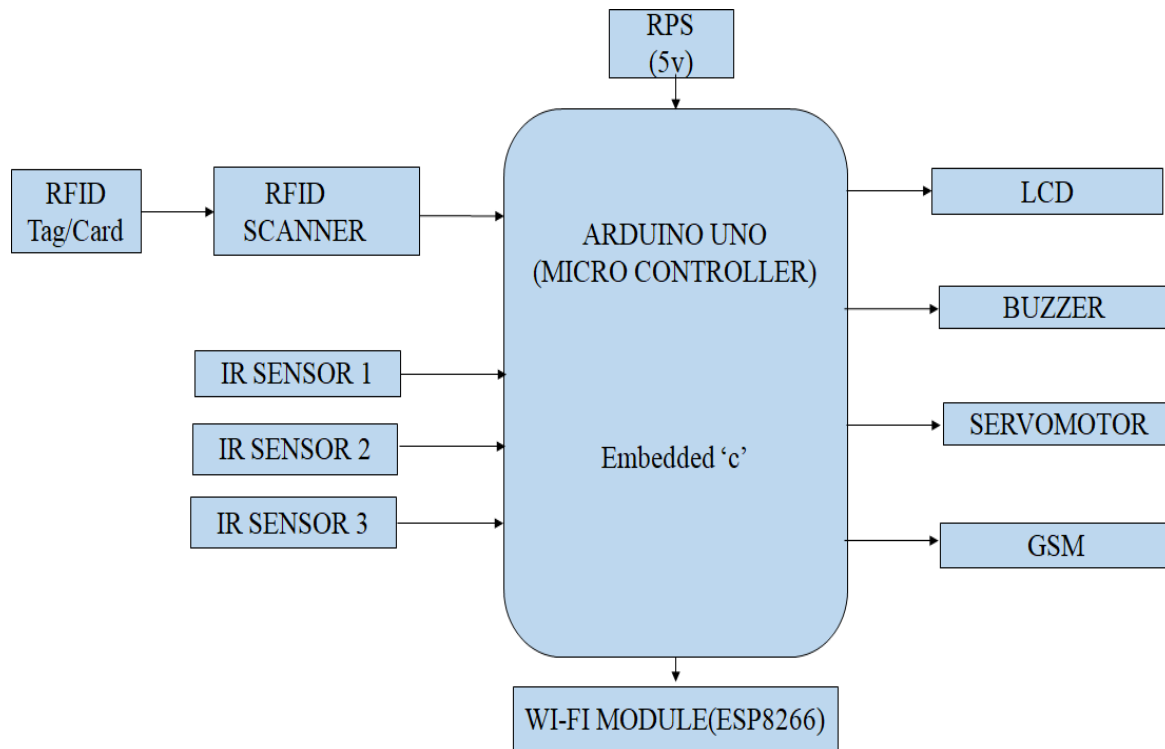

Arduino Uno Wi-Fi board is integrated with Wi-Fi module which will be used in this project. This board is based on integrated ESP8266 Wi-Fi Module and ATmega328P. The Wi-Fi module has TCP/IP Protocol stack which gives direct access to the Wi-Fi network. This board is programmed by using Arduino IDE software. This board is ideal as it can run both in online and offline mode.

This system having security for accessing vehicle using RFID. If the vehicle is valid then allow for payment of the parking fee after payment done servo motor will open and vehicle get in. after vehicle get in it will be placed in any of the parking slots. That parking slots information will post into IOT server. Microcontroller sends the status of all IR sensors to LCD module to display the available slots. GSM module will send the existing balance

when the user accessed into parking slot. We can get the status of the slots by keeping the GSM SMS alerts. Microcontroller reads the data display over LCD, GSM and IOT then user can easily access the data.

**Schematic Diagram:**

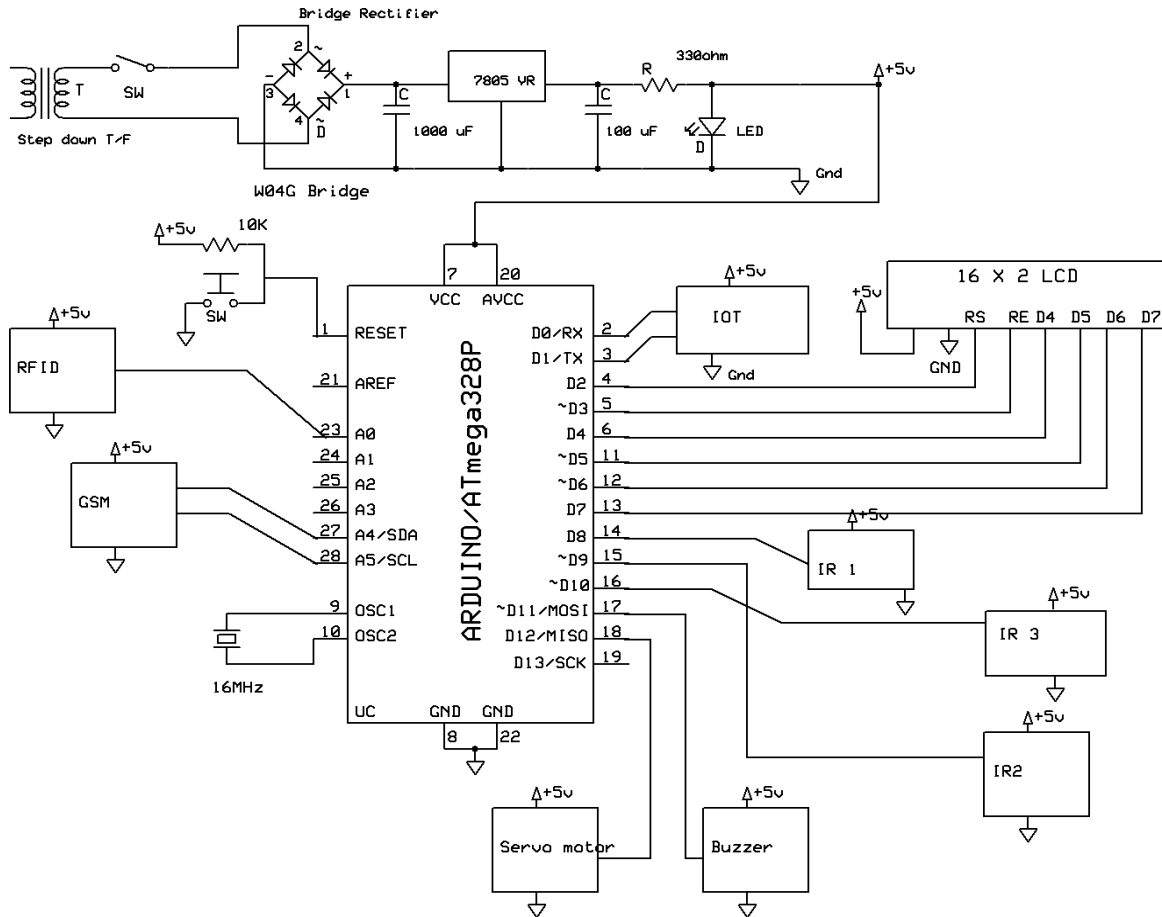

This is the pin diagram where all the hardware components are been connected components.this ARDUINO microcontrollerhaving28pins.Inwhich14GPIOpinsasdigitalpinsand6GPIOpins.16MHzcrystaloscillator connected internally.The step down transformer ,Bridge rectifier capacitor with 1000f Resistors and led are connected in Regulated power supplywhich provide the 5v to th e Arduino and all input/output modules.

**Schematic**

16\*2LCDDMonitorhasconnectedwiththeDigitalpins2,3, 4,5,6,7.

WIFIhasconnectedtoDigitalPinsD0,D1internalTransmitterandreceiverpins. 3IR

sensors connected to 8,9,10 pins of the Arduino micro controller.

RFID connected to digital pin

A0Servomotorconnectedtodigitalpin12

Buzzeralarmconnectedtodigitalpin11

GSM connected to A4 and A5.

#### 4. RESULTS



This is about the project named as IOT based Smart vehicle parking and automatic billing system.



Now send SMS to registered mobile number placed in GSM after checking the signal strength of the sim.



Then the LCD will display about the empty slots in each parking area in which cars need to be parked.

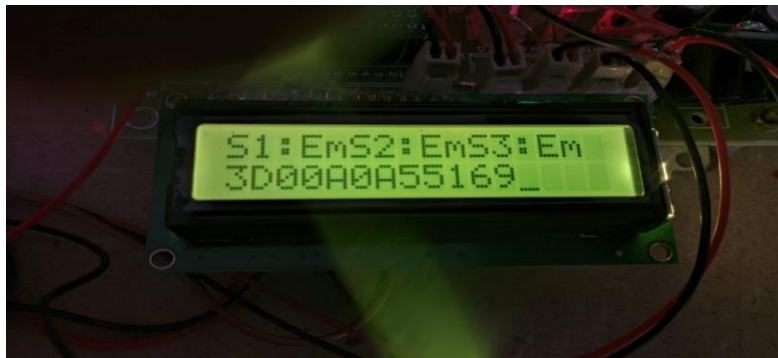

Now a car is parked in a parking slot and card number is 3D00A055169.



Then 10 rupees is debited for registered mobile number's wallet for each when the car is parked.

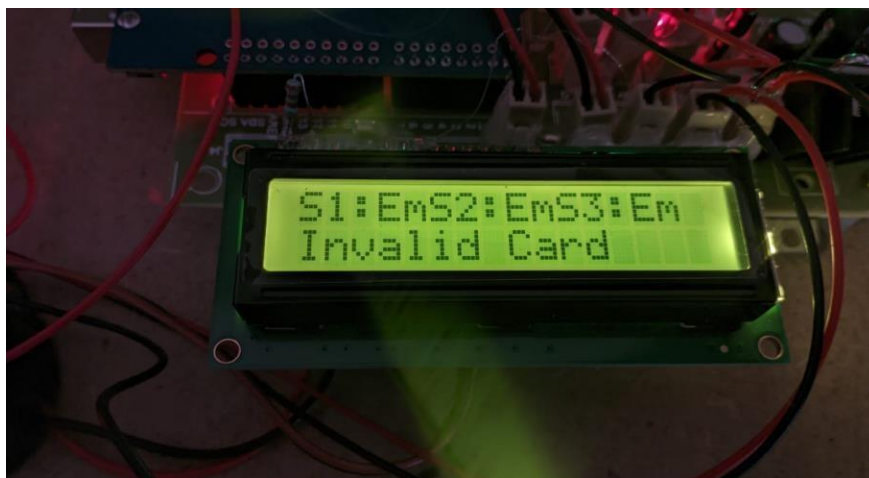

When the card is invalid, it means the mobile number is not registered and it has to be registered to enter into the parking slot and to get the gates opened to enter.

## 5. CONCLUSION

We designed and implemented an RFID/IoT-based smart secured vehicle parking system successfully. The project aims at designing an advanced smart parking system. In this system, we use IR obstacle sensors for vehicle presence detection, and these sensors are connected to an Arduino microcontroller. All 3 IR sensors detect the 3 parking positions; corresponding data will be posted on the LCD and IoT app. This system has security for accessing the vehicle using RFID. If the vehicle is valid, then allow for payment of the parking fee. After payment is done, the servomotor will open, and the vehicle gets in. After the vehicle gets in, it will be placed in any of the parking slots.

GSM module used send the balanced amount to authorized person and get the slots availability wirelessly from anywhere using GSM module. That parking slots information will post into IOT sever. Microcontroller send the status of all IR sensor to LCD module to display the available slots. Microcontroller read the data display over LCD and IOT then user can easily access the data.

## REFERENCES

1. Abhirup Khanna, R.A. (2016). IoT based Smart Parking System. International Conference on Internet of Things and Applications (IOTA) (p. 5). Pune: IEEE.
2. Kacheru, G. (2018). Blockchain Technology: Architecture, Applications, and Challenges. Turkish Journal of Computer and Mathematics Education (TURCOMAT), 9(3), 1433–1438.
3. Deng, D. (2015). A Cloud-Based Smart-Parking System Based on Internet-of-Things Technologies. IEEE , 11.
4. Kacheru, G. "The role of AI-Powered Telemedicine software in healthcare during the COVID-19 Pandemic." Turkish Journal of Computer and Mathematics Education (TURCOMAT) 11.3 (2020).
5. O.Orrie, B.S. (2015). A Wireless Smart Parking System. IECON (p.5). Yokohama: IEEE.
6. Khaoula Hassoune, W.D. (2016). Smart parking Systems: A Survey. IEEE,
7. Kacheru, G. "Aipowered test automation frameworks: choosing the right tools." International journal of artificial intelligence & machine learning (IJAIML) 3.02 (2024): 110.
8. Wael Alsafery, B. A. (2018). Smart Car Parking System Solution for the Internet of Things in Smart Cities. IEEE ,
9. Rachapo Lookmuang, K.N. (2018). Smart Parking Using IoT Technology. IEEE,
10. Mohit Patil, R. S. (2014). Smart Parking System Based On Reservation . International Journal of Scientific Engineering and Research (IJSER) ,