

Smart Irrigation Using IoT and ML: A Data-Driven Approach to Water Conservation

¹Prabhas Kumar Gupta, ² Dr Nagendra Tripathi

¹Research Scholar, ²Professor

¹Department of Electronics and Telecommunication, ²Department of Electrical Engineering

^{1,2}Bhilai Institute of Technology, Durg, India

ABSTRACT

Water scarcity remains a serious global challenge, and the situation is expected to worsen in the future. To mitigate this issue, innovative solutions for sustainable water management in agriculture are essential. Traditional irrigation methods often lead to inefficient water usage, resulting in higher water demand, excessive wastage, and negative impacts on crop production. This research presents a smart irrigation system that leverages the Internet of Things (IoT) and Machine Learning (ML) to optimize water management. The proposed system integrates real-time sensor data, including soil moisture, temperature, humidity, and weather conditions, to make intelligent irrigation decisions, maintain optimal soil moisture levels, and enhance crop health. This approach increases agricultural productivity while reducing water wastage. The findings of this study contribute to the advancement of smart irrigation systems, highlighting the potential of IoT, deep learning, sensors, and AI in transforming agriculture. Moreover, the research provides valuable insights for farmers, researchers, and policymakers in implementing sustainable and efficient irrigation practices.

Keywords: Smart Irrigation, IoT, Machine Learning, Water Conservation, Precision Agriculture, Sustainable Farming.

I. INTRODUCTION:

The world's population is rapidly increasing, driving a growing demand for food. The FAO projects that by 2050, the global population may reach 9.7 billion, requiring 160% more food than today. Agriculture, the backbone of any economy, must adopt technology to enhance efficiency and productivity.

One major challenge for farmers is water scarcity, leading to low yields, poor-quality crops, and failures. Traditional irrigation methods wastewater and lack real-time data on crop needs. A smart irrigation system can optimize water use, improving agricultural output.

This system integrates IoT-based sensors—soil moisture, temperature, humidity, and rain sensors—that collect real-time data. A central hub analyzes this data using machine learning (ML) algorithms to determine optimal watering schedules based on crop type, growth stage, soil, and weather conditions. Actuators, such as sprinklers and valves, are controlled accordingly.

ML and AI further enhance efficiency by predicting water needs, optimizing schedules, and detecting plant stress or disease. IoT enables remote monitoring and control through mobile apps or web interfaces, with communication via Wi-Fi, cellular networks, or LPWAN.

By leveraging advanced technologies, smart irrigation systems ensure efficient water use and sustainable farming.

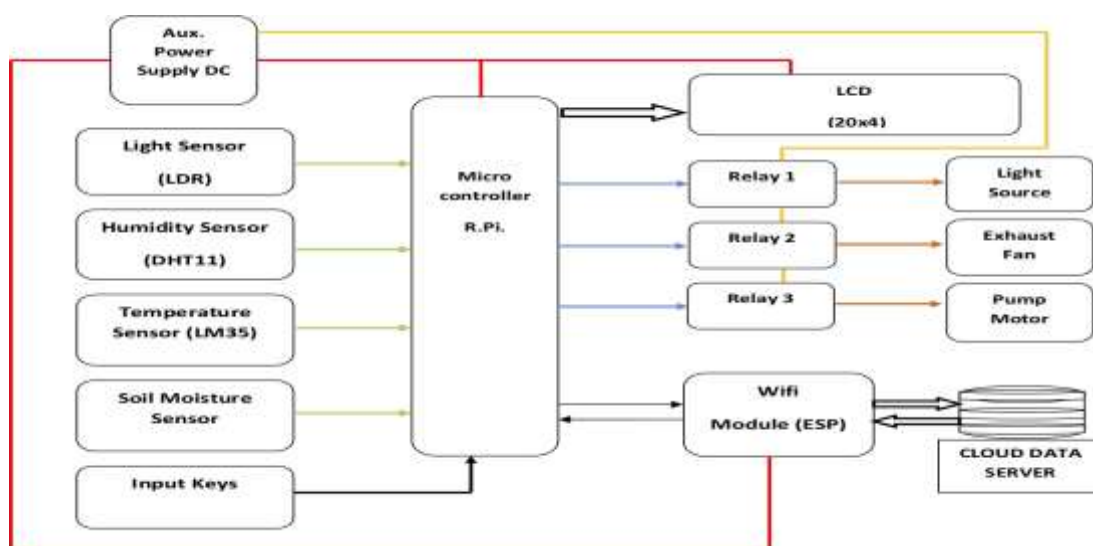

Fig 1.1 : Smart Irrigation System with IOT

The smart irrigation system using IoT offers numerous advantages over traditional irrigation systems, such as:

Water conservation: The system optimizes water usage by supplying the right amount of water at the right time, thus reducing water wastage, conserving water resources and ensuring that plants receive adequate moisture during critical growth stage

Improved crop yield and quality: The system ensures that the crops receive the right amount of water and nutrients, which helps in improving crop yield and quality.

Cost-effective: The system reduces the need for manual labour, reduce energy consumption and operational costs by avoiding unnecessary watering and optimizing the use of irrigation equipment, making it a cost-effective solution.

Real-time monitoring and control: The system provides real-time data on soil moisture levels and weather conditions, which helps in timely decision-making and prevents crop damage due to over or under watering.

Scalability: The system can be easily scaled up or down depending on the size of the farm or the number of crops being grown.

Remote access: The system can be accessed remotely from anywhere using a mobile phone or computer, which makes it easy for the farmer to monitor the crops and make necessary adjustments.

In conclusion, smart irrigation represents a significant advancement in agriculture, addressing the challenges of water scarcity, improving resource efficiency, and promoting sustainable farming practices. It provides real-time data on soil moisture levels and weather conditions, enabling farmers to make informed decisions and prevent crop damage. With the world's population expected to increase rapidly, the need for such technologies to enhance agricultural productivity and efficiency is more critical than ever.

1.1 Problem Statement

The problem addressed in this thesis revolves around the inefficiency and lack of precision in traditional irrigation methods utilized in agricultural practices. Conventional irrigation techniques often rely on fixed schedules or manual observations, resulting in suboptimal water distribution that leads to overwatering or underwatering of crops. This not only results in the wastage of valuable resources such as water and energy but also has detrimental effects on crop health and overall productivity.

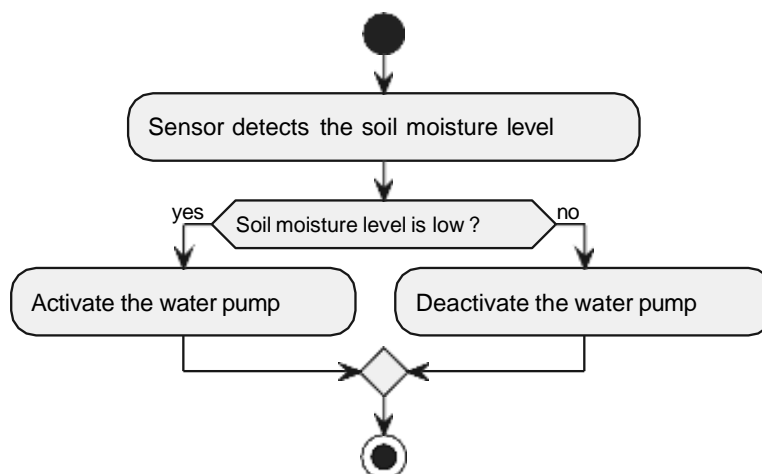

Fig 1.2: System Architecture of Smart Irrigation system

To address this issue, the thesis aims to develop a smart irrigation system that integrates sensors, ML algorithms, and Internet of Things (IoT) technologies. By incorporating sensors capable of monitoring crucial environmental parameters such as soil moisture levels, weather conditions, and crop health, the system can collect real-time data. This data is then processed and analysed using ML algorithms to make informed decisions regarding the timing and quantity of irrigation required.

The primary challenge that this thesis seeks to overcome is the development of an efficient and robust smart irrigation system capable of accurately monitoring and analysing various environmental factors. Additionally, the system needs to be capable of making intelligent decisions about irrigation schedules and ensuring reliable and secure communication with irrigation devices. To address these challenges, the thesis proposes a comprehensive methodology encompassing sensor selection, data processing, ML algorithm implementation, and the seamless integration of IoT technologies.

The ultimate objective of this thesis is to demonstrate the feasibility and benefits of employing smart irrigation systems in agricultural practices. By optimizing water usage and improving irrigation precision, these systems have the potential to contribute significantly to sustainable agriculture. The research findings and insights obtained from this thesis can serve as valuable guidance for farmers, agricultural professionals, and researchers interested in adopting smart irrigation techniques. These techniques have the potential to enhance crop yield, improve crop quality, and maximize resource efficiency while simultaneously reducing the environmental impact associated with traditional irrigation methods.

II. LITERATURE REVIEW

In the last decade, significant progress has been made in integrating Internet of Things (IoT) and Machine Learning (ML) techniques to develop smart irrigation systems with the primary objective of optimizing water use in agriculture. This section reviews notable contributions in this domain.

In [1], the authors proposed a smart irrigation system that combines IoT with advanced ML models, specifically an ensemble of Decision Tree Classifiers (DTC) and Random Forest Classifiers (RFC). The system analyzes environmental parameters such as soil moisture, temperature, pH value, and soil type to optimize water use, achieving an accuracy of 98.7%.

The study in [2] introduced a predictive analytics approach for optimal water scheduling using ML algorithms trained on real-time environmental data, including temperature and humidity. The study identified nine widely used ML models and evaluated their performance, highlighting the superiority of ML-based approaches over traditional methods in terms of accuracy and efficiency.

Furthermore, the research in [4] developed a smart irrigation system based on IoT and ML, utilizing sensors to collect data on soil moisture, temperature, and rainfall. Various ML models, including K-Nearest Neighbors (KNN), Logistic Regression, Neural Networks, Support Vector Machines (SVM), and Naïve Bayes, were tested, with KNN achieving the highest recognition rate of 98.3%.

Similarly, in [5], an IoT-enabled intelligent irrigation system was implemented for efficient rice cultivation. The system used sensors to collect environmental data, which was processed using ML models such as Artificial Neural Networks (ANN), SVM, Decision Trees (DT), and Random Forests (RF). The ANN model demonstrated the highest accuracy at 95.6%, facilitating precise water adjustments and promoting sustainable agriculture.

Additionally, the study in [6] proposed a deep learning-based sensor modeling approach for smart irrigation systems. By employing Long Short-Term Memory (LSTM) neural networks, the system predicted environmental parameters such as temperature, humidity, and soil moisture, thereby increasing the reliability and efficiency of irrigation practices.

From the reviewed literature, it is evident that integrating IoT and ML techniques in irrigation systems significantly enhances water management efficiency. However, challenges such as sensor reliability, computational complexity, and adaptability to diverse agricultural contexts remain. This research aims to address these challenges by developing a robust IoT and ML-powered smart irrigation system that ensures real-time monitoring, predictive analysis, and efficient water use in agriculture.

III. METHODOLOGY

3.1 Overview

Implementation Steps

1. Network Connection & Initialization
 - Connect to Wi-Fi and initialize components (UART, pins, LEDs).
2. Time Synchronization
 - Use the `ntptime` library for accurate timestamps.
3. Weather Data Retrieval
 - Fetch weather data from the OpenWeatherMap API using `get_weather()`.
 - Process JSON responses to extract key parameters (temperature, humidity, cloudiness).
4. Data Display & Communication
 - Display weather data on an LCD.
 - Read serial data from the microcontroller via UART.
5. ThingSpeak Integration

- Send collected data to the ThingSpeak IoT platform using its API.
6. Continuous Operation
- Refresh weather data every 30 seconds for real-time updates.

System Architecture

The system consists of a microcontroller with UART communication, a Wi-Fi connection, and API integration. It retrieves real-time weather data, processes it, and exchanges information with the microcontroller. Data is stored on ThingSpeak for visualization and analysis. The system runs continuously, ensuring updated information for optimal irrigation.

Data Collection & Processing

Weather data is collected from the OpenWeatherMap API using `get_weather()`, extracting key parameters like temperature, humidity, and sunrise/sunset times for analysis and decision-making in the smart irrigation system.

This structured approach ensures efficient and real-time irrigation management.

Smart Irrigation System Data Flow Diagram

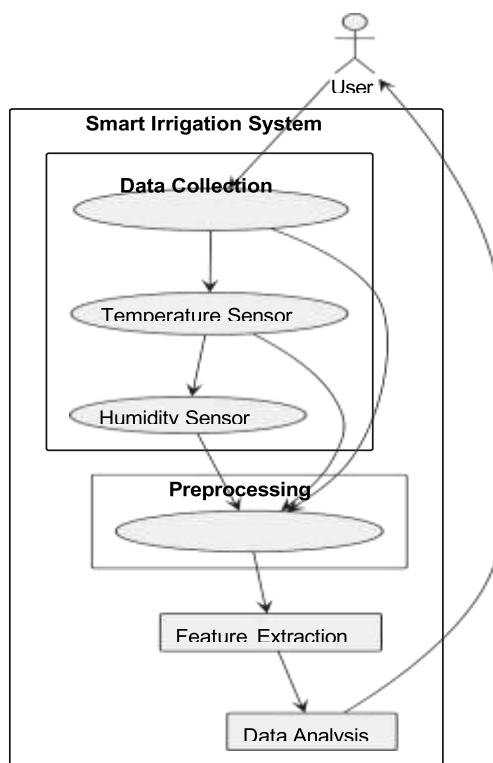

Fig 3.1: Flowchart of Data collection and Pre-processing

Once the weather data is obtained, it is processed and displayed on an LCD. The collected data is also communicated to a microcontroller through UART for further processing and analysis.

In addition to data collection, this implementation involves the integration of AI for prediction. It is implemented separately in a Google Colab, it provides a platform for training machine learning models using weather data to predict irrigation requirements or other relevant parameters.

The collected weather data is used as input features for AI models, regression or classification algorithms are used to predict irrigation needs decisions. Google Colab offers a range of AI libraries and tools, such as TensorFlow or scikit-learn, which can be utilized for building and training machine learning models. We are utilizing TensorFlow for our project. Overall, the data collection and processing stage focuses on retrieving weather data, processing it for display and communication, and creating the foundation for AI-based prediction models that can be developed using platforms like Google Colab.

IV. IMPLEMENTATION AND RESULTS

4.1 Hardware and Software Setup

This section outlines the hardware and software setup for implementing the smart irrigation system using Raspberry Pi Pico, OpenWeather API, LM35 temperature sensor, LDR, DHT11 humidity sensor, and an ESP WiFi module.

4.1.1 Hardware Components

- Raspberry Pi Pico: A microcontroller with an RP2040 chip, dual-core Cortex-M0+, 264 KB SRAM, and 2 MB Flash memory. It supports UART, SPI, I2C, ADC, and PWM for sensor interfacing.
- LM35 Temperature Sensor: Measures temperature from -55°C to 150°C with $\pm 0.5^{\circ}\text{C}$ accuracy.
- LDR (Light Dependent Resistor): Detects ambient light intensity for optimizing irrigation schedules.
- DHT11 Humidity & Temperature Sensor: Provides 20-80% humidity readings and a temperature range of $0-50^{\circ}\text{C}$.
- ESP WiFi Module: Enables internet connectivity for real-time data transmission via ThingSpeak and OpenWeather API.

4.1.2 Software Setup

- MicroPython on Raspberry Pi Pico: Enables Python programming on the microcontroller.
- ThingSpeak API Integration: Allows real-time data collection, visualization, and analysis in the cloud.
- Sensor Libraries: Required for interfacing with LM35, LDR, and DHT11 sensors.
- WiFi Configuration: Establishes network connectivity for remote monitoring.
- Data Processing & AI Algorithms: Uses Python for sensor data analysis, weather predictions,

and intelligent irrigation decisions.

4.1.3 Hardware and Software Integration

- Connect sensors (LM35, LDR, DHT11) to Raspberry Pi Pico.
- Flash MicroPython firmware using Thonny IDE.
- Install and import necessary sensor and WiFi libraries.
- Configure ESP WiFi for internet access.
- Implement Python-based data processing and irrigation control algorithms.
- Retrieve and analyze data from ThingSpeak and OpenWeather API.
- Train an AI model on Google Colab to optimize irrigation based on weather and soil moisture data.
- Continuously monitor and adjust irrigation settings based on real-time data.
- This system enables real-time monitoring of environmental conditions, optimizing water usage and enhancing crop yield.

4.2 Data Collection and Analysis

- Collected data is stored in ThingSpeak and analyzed using AI and machine learning algorithms for informed decision-making.
- Data Analysis Steps:
 - Pre-processing: Handle missing values, outliers, and normalize data.
 - Feature Extraction: Identify key factors such as soil moisture, temperature, humidity, and rainfall.
 - AI Model Training: Train models using Decision Trees (DT), Support Vector Machines (SVM), and Random Forests (RF).
 - Model Evaluation: Assess performance using accuracy, precision, recall, and F1 score.
 - Decision Making: Adjust irrigation schedules based on AI predictions and real-time sensor data.

1	created_at	entry_id	Temperature	Moisture	Light Intensity	Humidity
2	2023-05-12T16:07:11+05:30	1	34.17647	51.20928	15.92977	12
3	2023-05-12T17:40:16+05:30	71	33.74208	54.01694	1.783206	12
4	2023-05-12T18:02:42+05:30	144	36.13122	55.01793	1.392366	14
5	2023-05-12T19:01:46+05:30	226	34.75566	54.65171	1.514504	26
6	2023-05-12T20:00:07+05:30	312	37	52.33234	1.196947	23
7	2023-05-12T21:28:49+05:30	410	45.69231	51.55108	13.43817	27
8	2023-05-12T22:01:40+05:30	433	38.52489	49.96262	1.416794	26
9	2023-05-12T23:21:46+05:30	464	48.87783	50.67216	13.46259	20
10	2023-05-13T09:28:33+05:30	562	42.86878	52.96712	1.416794	20
11	2023-05-13T10:02:55+05:30	630	29.68778	46.37369	1.465649	17
12	2023-05-13T11:03:31+05:30	739	45.61991	40.90334	16.19847	17
13	2023-05-13T16:05:42+05:30	858	36.9276	68.03387	1.832061	15
14	2023-05-13T17:35:06+05:30	916	29.32579	63.83459	1.636641	13
15	2023-05-13T18:01:43+05:30	1003	29.1086	62.78477	15.58779	14
16	2023-05-13T22:10:41+05:30	1012	39.39367	60.46387	1.490076	23
17	2023-05-13T22:23:42+05:30	1055	37	59.41405	1.441221	22
18	2023-05-13T22:36:07+05:30	1096	32.72851	58.68162	14.46412	28
19	2023-05-13T23:12:29+05:30	1216	31.42534	56.55756	14.48855	31
20	2023-05-14T10:28:11+05:30	1485	27.22624	62.78477	1.783206	15
21	2023-05-14T14:29:59+05:30	1721	33.95927	59.63379	16.24733	7
22	2023-05-22T17:16:36+05:30	2147	30.70136	0	1.465649	11
23	2023-05-22T20:45:57+05:30	2416	24.47511	69.96414	16.36946	19
24	2023-05-23T09:48:35+05:30	2837	47.21267	62.98009	39.92366	24
25	2023-05-23T22:10:07+05:30	3250	23.96833	64.83559	16.10076	41
26	2023-05-24T08:36:49+05:30	3605	27.95023	40.12207	38.60458	25
27	2023-05-24T09:44:18+05:30	3828	32.14932	33.28451	43.78473	17
28	2023-05-24T16:22:04+05:30	4627	23.24434	71.38018	16.36946	13
29	2023-05-25T12:41:38+05:30	5474	30.84615	28.71748	13.58473	16

Tab 4.1 : Dataset Generated at Thingspeak

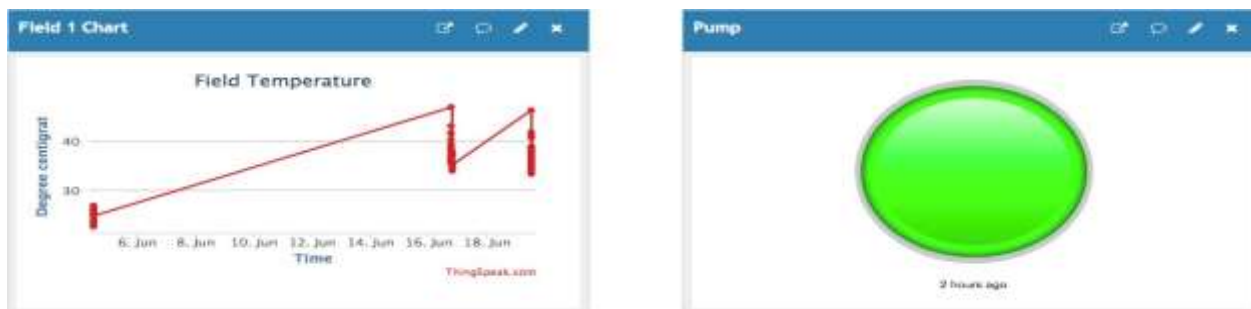

Fig 4.1: Field 1 – Temperature Visualization at Thingspeak



Fig 4.2: Field 2 – Moisture



Fig 4.3: Field 3 – Light

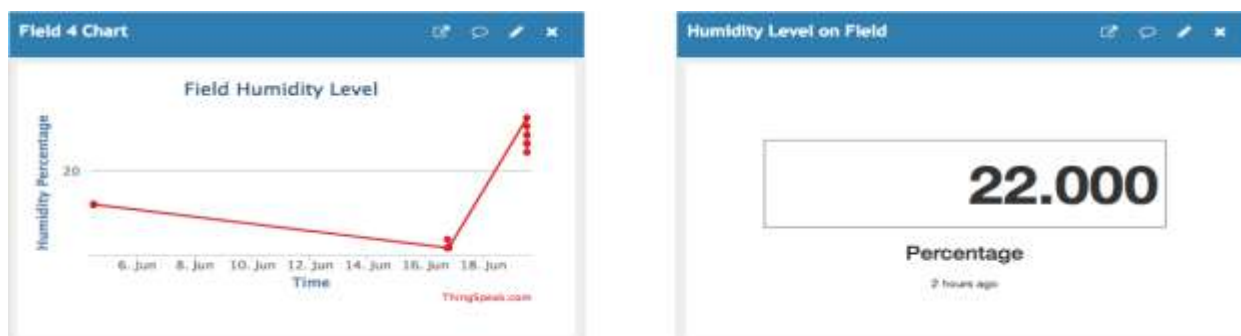

Fig 4.4: Field 4 – Humidity

4.3 Performance Evaluation

This section evaluates the smart irrigation system's performance using AI and ML techniques. The assessment focuses on optimizing water usage and improving crop yield through data collection, experimental design, performance metrics selection, and comparative analysis.

4.4 Data Collection

A substantial dataset is required for comprehensive evaluation. Data collection includes sensor readings (soil moisture, temperature, humidity, and light), weather data (temperature, precipitation, wind speed, and solar radiation), crop characteristics (growth stage, type, and water needs), and irrigation schedules (timings and durations).

To ensure robust results, data is gathered from multiple locations and seasons. The collected data is stored in ThingSpeak, providing real-time visualization and analysis.

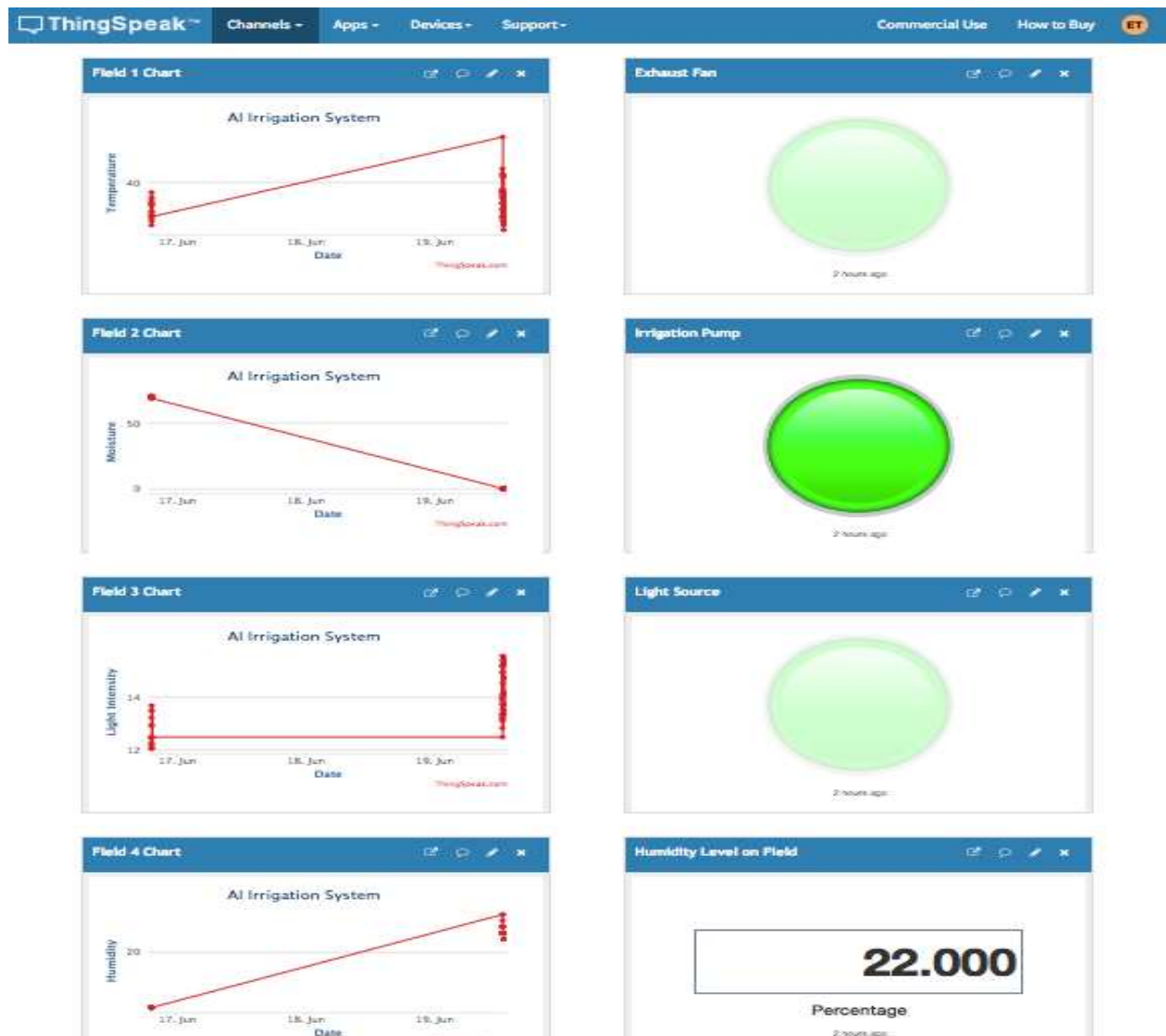

Fig 4.5 : Realtime Data Generation at ThingSpeak

4.3 Interpretation of Results

The results obtained from the performance evaluation are interpreted to draw meaningful conclusions regarding the effectiveness and potential of the smart irrigation system. The interpretation involves analyzing the statistical significance of the findings, identifying trends and patterns, and relating the results to the initial objectives and hypotheses.

Comparison Between Different Algorithms

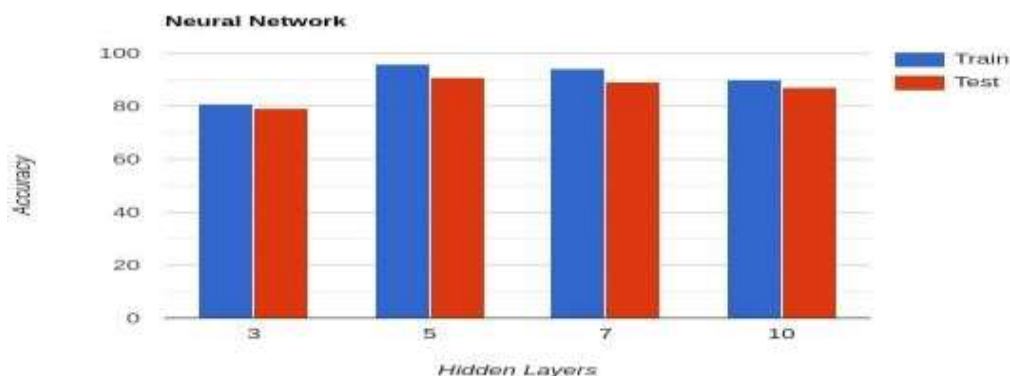

Fig 4.6 : Deep Learning Hidden Layers

Here we have used deep learning and Here are the result for various hidden layers in deep learning model which are 3, 5, 7, and 10.

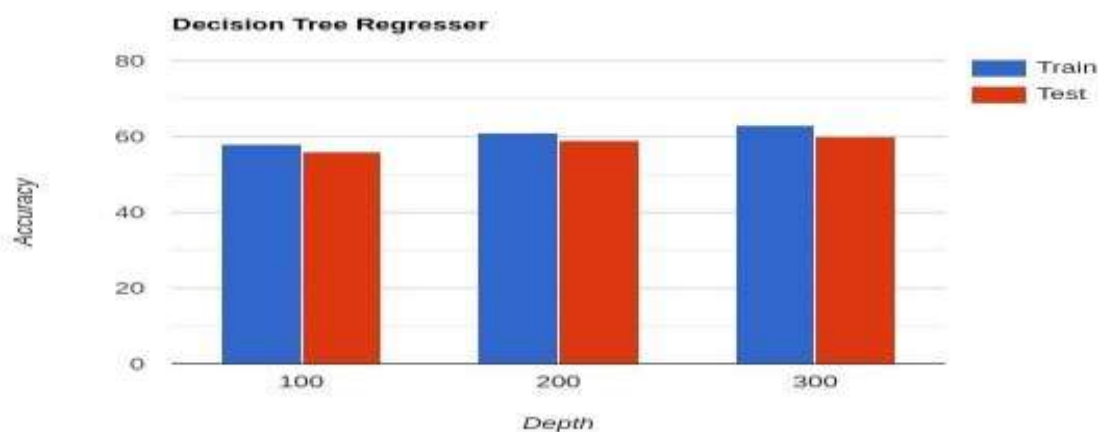

Fig 4.7 : Decision Tree Regression Depth

Here DT regression is used and the depth of the tree is the number of split of the node for prediction and values are 100, 200, 300 and accuracy for train and test is shown in the figure.

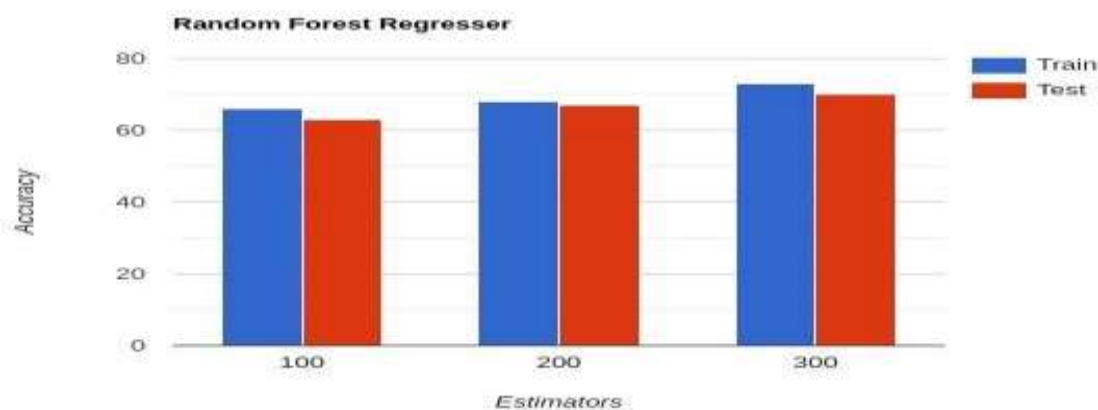

Fig 4.8 : Random forest regression

RF regression is used for training and testing and the estimator is number of tree present in RF.

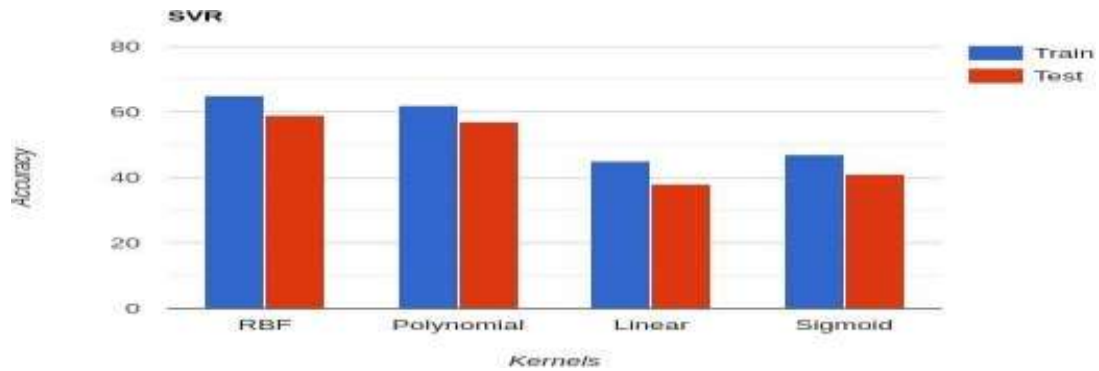

Fig 4.9 : Different Kernel in SVR

Here is Support Vector Regression and we used different kernels to find train and test accuracy. Kernel is used to transform the data to make prediction correctly.

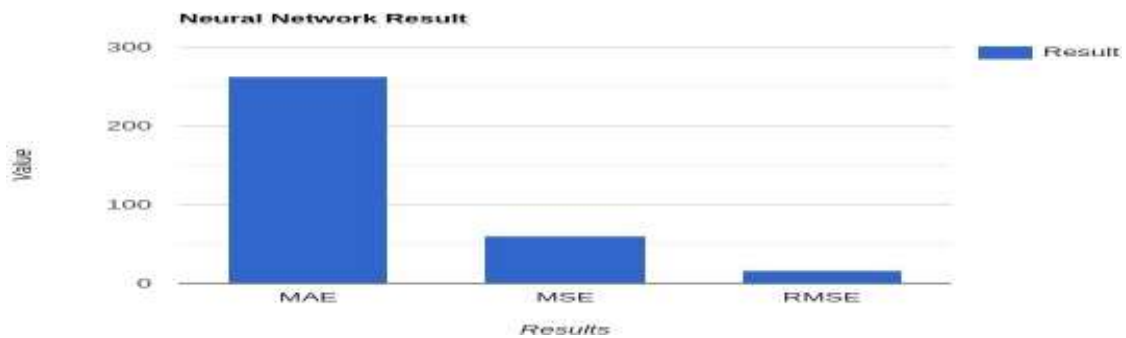

Fig 4.10 : Neural Network Result

V DISCUSSION

5.1 Interpretation of Results

This section analyzes the performance of the smart irrigation system based on experimental data. The system's effectiveness in water conservation and crop yield optimization was evaluated using machine learning (ML) models such as Decision Trees (DT), Support Vector Machines (SVM), and Random Forests (RF).

Key findings include:

- **Water Conservation:** The system significantly reduced water wastage by dynamically adjusting irrigation schedules based on real-time sensor data.
- **Crop Yield Optimization:** Accurate monitoring of soil moisture and weather conditions ensured optimal irrigation, leading to improved crop yield and quality.
- **ML Model Performance:** The models demonstrated high accuracy in predicting irrigation needs, validated using precision, recall, and F1 score.
- **IoT Integration Benefits:** Seamless data exchange enabled real-time monitoring and remote irrigation management, enhancing system efficiency.
- **Challenges Identified:** Implementation costs, network reliability, and sensor calibration were noted as areas for future improvement.

Overall, the results confirm that integrating sensors, ML, AI, and IoT in smart irrigation enhances water efficiency and sustainability in agriculture.

VI. CONCLUSION AND SCOPE FOR FUTURE WORK

6.1 Summary of Findings

The research findings highlight the impact and feasibility of smart irrigation systems. Key conclusions include:

- **Effectiveness of Smart Irrigation:** The system successfully optimized irrigation based on real-time data, reducing water wastage.
- **Sensor-Based Monitoring:** Soil moisture, temperature, and humidity sensors enabled precise irrigation control.

- ML for Decision Support: AI models accurately predicted irrigation needs, improving resource management.
- IoT for Real-Time Data Transmission: Remote access and automated decision-making enhanced operational efficiency.
- Water Efficiency & Crop Yield: Improved irrigation practices led to higher crop productivity.
- Sustainability & Resource Conservation: Reduced water usage supports sustainable agricultural practices.
- Scalability & Adaptability: The system can be expanded for different crops and climatic conditions.
- Challenges & Future Scope: Addressing cost, network reliability, and sensor calibration will improve adoption and efficiency.

References

- [1] U. Roy B.P., S. Kumar, and M. Singh, "A Smart Irrigation System Using the IoT and Advanced Machine Learning Model," *Journal of Smart Internet of Things*, vol. 2024, no. 2, pp. 13–25, Feb. 2025. [Online]. Available: <https://sciendo.com/article/10.2478/jsiot-2024-0009>
- [2] M. R. Kumar, "Machine Learning-Driven Predictive Approach for Optimal Water Scheduling in Smart Irrigation Systems," *International Journal of Communication Networks and Information Security (IJCNIS)*, vol. 15, no. 4, pp. 685–690, Oct. 2023. [Online]. Available: <https://www.ijcnis.org/index.php/ijcnis/article/view/7745>
- [3] M. A. Khan, M. S. A. Khan, and S. A. Khan, "The Application of Machine Learning Techniques for Smart Irrigation Systems: A Systematic Literature Review," *Smart Agricultural Technology*, vol. 7, pp. 100425, Mar. 2024. [Online]. Available: <https://www.sciencedirect.com/science/article/pii/S2772375524000303>
- [4] A. El Amrani, M. El Amrani, and A. El Amrani, "Smart Irrigation System Based on IoT and Machine Learning," *Energy Reports*, vol. 8, suppl. 9, pp. 1025–1036, Nov. 2022. [Online]. Available: <https://www.sciencedirect.com/science/article/pii/S2352484722013543>

- [5] R. Y. Mujawar, R. Lakshminarayanan, J. A. P., S. P. P., S. Patnaik, and K. Dhayalini, "IoT-Enabled Intelligent Irrigation System with Machine Learning-Based Monitoring, for Effective Rice Cultivation," *International Journal of Intelligent Systems and Applications in Engineering*, vol. 11, no. 2, pp. 123–130, Apr. 2023. [Online]. Available: <https://www.ijisae.org/index.php/IJISAE/article/view/4476>
- [6] M. A. Khan, M. S. A. Khan, and S. A. Khan, "A Deep Learning-Based Sensor Modeling for Smart Irrigation System," *Agronomy*, vol. 12, no. 1, pp. 212, Jan. 2022. [Online]. Available: <https://www.mdpi.com/2073-4395/12/1/212>