

10.48047/jocaaa.2024.33.05.33

MISSING PEOPLE IDENTIFICATION SYSTEM IOT

¹B.Maheshwari, C.Sai Nithya², B. Shivani³, J. Pushpa latha⁴

¹Assistant Professor, Department of Information Technology, Sridevi Women's Engineering College,
Hyderabad

Email: swecmaheshwari@gmail.com

^{2,3,4}Department of Information Technology, Sridevi Women's Engineering College,
Hyderabad

ABSTRACT: The rising number of reported missing persons is directly correlated to India's rapid economic development. Getting those who have gone missing and recognizing them is a positive step in reducing the number of missing persons in India. Connected electrical, mechanical, and human-made objects with unique IDs and the ability to communicate data constitute what is known as the Internet of Things (IoT). The Internet of Things (IoT) eliminates the need for human-to-human or human-to-PC communication by connecting various sensors in a network and exchanging data via various connection protocols. An innovative approach for detecting missing people in the IoT is shown here. All smart city/area locations are meant to be liveable within the suggested framework. This system may identify a missing individual and relay their live picture and whereabouts to the nearby police station if they are apprehended.

Keywords: Internet of Things, network, protocols, mechanical, electrical

1.Introduction

The Internet of Things (IoT) is a clever system in which all the parts work together to facilitate the exchange of data and communication via sensing devices. Kevin Ashton coined the phrase "Internet of Things" in 1999. With the help of the Internet of Things, many different fields and industries have begun to use various forms of "smart" technology, including transportation, healthcare, the grid, water management, infrastructure, noise monitoring, and health monitoring. With the Internet of Things (IoT) already in its early phases of development, new commercial applications or improvements to current processes may be made possible [1]. The next signup window will not be accessible from a desktop computer. There will be a wide variety of things on the network in the IoT. Radio Frequency Identification (RFID) and other sensor-based technologies will face this new challenge in the

context of a communication structure with data discreetly integrated at ground level. The inexhaustible data set is prepared, trustworthy, and offered in a sustainable, safe, and readily interpretable format. Internet of Things (IoT) challenges include memory overheads of smart devices and generally accepted computing limitations. Overall, India's economy has risen in

the last few decades. An uptick in the number of individuals reported missing is a direct consequence of the rapid economic growth. For Indian society as a whole, security concerns are always at the top of the list. An increasingly serious threat to our society is the rising number of missing persons in India. Finding missing people in our culture is challenging due to the limited information accessible for police records, including photos and basic details about the missing person. Unfortunately, a large proportion of missing individuals in India never make it home or return to their families. Our team has developed an Internet of Things (IoT) method to identify individuals who may be missing. This technology can track a person's whereabouts in real time, attach a picture, and notify the nearest police station as well as the person's family if they are missing. It will be necessary to operate very dynamic and lively ad-ho connections in order to explain the work processes in the researched undertaking environment, the house, the workplace, and other dazzling locations in the future via cross association connections. There is a severe lack of available ICT assistance at the moment, and the corresponding critical issues are still prevalent. The Internet of Things has the following difficulties [12]. One of the main obstacles to the Internet of Things (IoT) is the present Internet architecture, which has constraints in terms of scalability, availability, manageability, and mobility. 2. Trust, Privacy, and Security—In the realm of security, the obstacles include:

- Ensuring security throughout design and implementation of the Internet of Things (IoT) architecture,
- Predictive detection and prevention of misuse and arbitrary assaults on the Internet of Things (IoT) devices against malicious malware.

The proactive detection and defense of Internet of Things (IoT) devices against malicious malware. The following issues are unique to the field of user privacy:

- The need for privacy-enhancing technology and applicable protection laws;
- The need for control over personal information (data privacy) and the ability to control over an individual's physical position and movement (location privacy).

Thirdly, a big difficulty is managing heterogeneity, which includes applications, environments, and devices. Managing massive amounts of data and extracting valuable insights from massive amounts of data are two of the biggest obstacles. Other significant challenges include:

- Creating an effective architecture for sensor networking and storage;
- Coming up with ways to discover new sensor data;
- Creating protocols for communicating sensor data, such as querying and publishing/subscribing;
- Creating systems to process sensor data streams; and
- Mining sensor data, including designing correlation and aggregation filtering techniques.

In conclusion, it will be very difficult to standardize various technologies, devices, application interfaces, etc. A missing person is usually shown as the person who goes missing, whether purposefully or accidentally. This person might be a little kid or an adult. Among the many

types of missing cases, only 43% have their causes determined; 99% involve juvenile delinquency; 2500 involve problems inside the family; and around 500 involve individuals from outside the family (including both adults and teens).[7] Very little research has focused on the social realm into which a little kid vanishes in India. The purpose of this essay is to examine the missing children situation by building on comprehensive reports derived from secondary sources and previous literature on the strengths and weaknesses of Indian elementary school students. The findings indicate that the interconnectedness of human science adds to the mystery of missing children. These children, who come from disadvantaged backgrounds and are often victims of social, commercial, and sexual exploitation, are abducted, sold, or duped. In order to fill in the gaps that need mediation, our investigation was driven by a desire to get a deeper understanding of the missing children issue. About 52% of the missing cases are women's and 48% are men's."In India, there are no spending plans designated to discovering missing individuals," a government official source said. Although a missing person may encounter many obstacles, very few really face the threat of death (murder), violence, or abuse. Not knowing whether a loved one is alive or dead puts a strain on those who are concerned about them, including guardians, companions, family members, and gatekeepers. Our system stores the client-provided photo of the missing person in the database at the time of the incident. Anyone in an uncertain situation may have their picture transferred to the general public. Our system will automatically detect whether there is a match for this image in the dataset of all the photographs. When a suspicious person is located, the face recognition model compares their current image to the photos sent by the watchdog/police division at the time of the disappearance. In the event that a match is found, the client will be notified. If it can't be located, the transferred image will be added to the dataset as a new record. The time it takes to find someone's details once they've been located is reduced in this way.

2.Literature Review

- Facial Feature Retrieval with Deep Learning The photographs of the missing children are saved in a database after their extraction and coordination using SVM (Support Vector Machine). A Convolutional Neural Network learns facial traits from these photographs and uses them to recognize faces. A multi-class support vector machine classifier was trained using these characteristics. They successfully identified and labeled the child using this way. The key distinction between our system and theirs is that, unlike in their system, once a

person is located, our public can register their face as a lost person along with the details of their discovery in our portal. This feature was not previously available in their database. Searching will be facilitated more quickly by this. The extraction and classification processes are slowed down by their system's complicated algorithms. These are the primary issues with the old systems. A facial recognition system developed utilizing the PCA technique. The computational complexity and the fact that it can only handle faces with comparable expressions are the two major drawbacks of the principal component analysis (PCA) approach. LBPH is a face recognition technique. A 70.5% success rate in facial recognition was achieved by the suggested technique. There is no sensitivity of the LBPH algorithm to variations in brightness. In order to calculate each pixel in the patch, SIFT relies on the Histogram of Gradients, which is computationally intensive and time-consuming. The Line Edge Method (LEM) is a facial recognition tool for locating individuals who have gone missing. This system had an efficiency level of 85%. A system that uses radio frequency identification technology to find missing persons. It's not practical for the individual to physically wear the RFID tag all the time, which is a drawback of the system [6].

In their introduction to the Internet of Things (IoT), the authors [1] lay out the fundamentals. It shows how the customer-driven cloud-based approach learns about private and open markets to get closer to this goal. Those requirements of the final consumer would be prioritized in this manner. Those substantial adaptability factors will fulfill the planned. When addressing needs across departments, we often advise a cloud-enabled framework that can accommodate the Internet of Things (IoT). By separating frameworks management, computation, and representational issues, this framework enables sparse innovation in these areas. Inseparable but complementary, bound together by a same web address. With cloud computing at its core, the growth of these disciplines' institutionalization will not be negatively affected. The new structure-related obstacles have been identified and described in the best possible light, and they are symbolic of the infinite informational measures that must support such initiatives, including protection, security, and the bulk of data organization concerns. A goal-oriented stage will be very beneficial. With their comprehensive overview of the mix and practical parts that may be passed on to an operational IoT, those universities claiming global exercises will undoubtedly be revitalizing progress towards an IoT.

- The author's [2] arrangement began with the assertion that an IoT-built framework for identifying wrongdoing. The schema relies on people's feelings and the acceptance of lawbreakers as persistent. The schema of the wrongdoing identification framework determines which customers are at risk of dangerous wandering and which will have a

wearable identifying device attached to their clothing. Devices like this record vital signs like a customer's pulse and temperature. However, such feelings might be inaccurate. More than 36 different energy states may be detected by such CCTV cameras. Thus, inventor [2] applies k-implies figuring with regard to illustration with accomplish consistent wrongful detection. So that those annoyingly far individuals from the group's conceptual center, K-implies count bunches Seoul locations under k bunches. The moment at which the most appropriate groups, such as the police, emergency services, and guardians, would permit the identification of a man in need of assistance. However, each infraction will be documented in the database and visualized using the electronic Geographic data framework (GIS). You need it. Facilities that are suitable for groups other than police officers.

The creator [3] should have suggested the system and procedure for identifying misbehavior. Also, a data-mining framework for missing person IDs in Indian metropolitan areas. Information extraction (DE) is the first of six modules that Writer [3] suggests using in a framework. Data pre-processing (DP) is the second. Clustering, Google Guide representation, What's more arrangement, and WEKA execution make up the third module. Using kimplies grouping, which repeatedly creates two groups of wrongdoing based on shared characteristics, it is possible to deconstruct wrongdoing identification. A collaborative enhancement of CDCI with DMT for Indian urban zones was proposed by Creator [3]. Rates of misbehavior are the deciding factor for seven urban groups in India. CDCI retrieves unstructured criminal data from several unreliable online sources. Here is the data The 5,038 samples that were spoken should be pre-processed using 35 predetermined violations characteristics after the incorrect finishing data was removed. The secret message assured that the user interface (UI) could be designed to receive the CDCI mechanical assembly. After that, CDCI uses four scenarios from 2000-2012 to apply k-implies grouping to missing individual area. device using WEKA on a CDCI table 1. G1 and G2 groups id al-adha using k-means G1 2,445 2,289 G2 2,593 2,749 126 ai k-implies (WEKA) k-implies (code) Measure an accuracy of 93.62% and 93.99%, independently, in the framing of two wrongdoing groups using selected wrong do ingtraits(Soc(2015)30:117-127123).

- Using these images from live-streaming CCTV video, the framework proposed by the author [4] may identify the forgetful person. Comparing it with those missing representative databases is much more daunting. Displays additional details about the images that correspond to the records in those databases. It uses the Eigen values for discrimination and the HAAR calculations for face identification. A person's eyes, nose, and lips are just a few examples of the characteristics that will be used. The framework that corresponds to those

pictures after those wrongdoings have been committed may be advanced.

- A scenario identification algorithm based on instructions specific to closed-circuit television (CCTV) perception frameworks was shown by the author [5] in their work. To decide on low-level depictions concerning predetermined occurrences, we employ blob and scene important attributes, such as blob position alternately velocity and people thickness, which get us closer to the viewpoint divide. They may be remembered by those schemas, which differentiate grouping criteria and semantic portrayals of occurrences related to those available situations. Additionally, they could raise a flag of the administrator, who makes ultimacy decisions. Here we will go over the specific requests made to CCTV surveillance systems in relation to open transport situations, as well as those valid picture taking care of methods, all with the end goal of building a smart perception skeleton that can identify potentially dangerous wandering conditions.

In order to combat MFF-based attacks, the author [6] suggests using face Live, a traditional and robust livens distinguishment framework, to strengthen the face confirmation while peering at locked mobile phones. Persistent facial expressions reveal attacks At last, Tom is reading up on the consistency measurements between the data collected by the inertial sensors and the head posture changes detected by the inalienable Polaroid. Going live won't be a problem since it doesn't need any further materials. Regardless, a lame front facing the camera, an accelerometer, Additionally, a whirligig, which requires assistance in order to open for modern mobile phones, Prior to this, the author [7] proposed a light-based, turn-invariant multi-view face distinguishment system for actual Ad boost calculation. People's faces need assistance that is categorized into a few of categories that are also shown. In the end, Tom's exploring those many viewpoints, beginning with changed ones. Weak classifiers want assistance coordinated as an assurance-assessed look-into table (LUT) of Haar highlight for every viewpoint categorization. An Adaboost figure is used to support these delicate classifiers and develop a calming composed face detector. As a result, it will be transformation invariant, divided into 12 sub-ranges, and their related see-based finders will be raised freely. Introducing a stance estimate technique with improved execution results in a four-case-per-second handling speed on a 320/spl times/240 measured image. The frontal face locator subsystem recovered 94.5% of the appearances for 57 false cautions on the CMU+MIT frontal face test set, and the multi-see face distinguish subsystem recovered 89.8% of the countenances with 221 false alerts on the CMU profile face test situated, when taking into consideration probes appearances with 360-degree in-plane transformation and/spl mnplus/90-degree out-of-plane transform into consideration. Area based spatial protest

determination was shown by the author [8]. Developing a critical request viewpoint on the acquisition of intelligent media networking database frameworks is another area of investigation. Problems should be shown using the methods that are utilized as indicators of A area with two dimensions that is going to be asked for At last, Tom is exploring the data structure using a multidimensional majority. It is necessary to advise territory on a few data structures. In addition to spatial ordering, there should be documentation of both coatings to prevent someone from claiming they are being referred to. Moreover, areas that do not provide coverage Regarding a flawless request recovery throughout time. The designer showcases the hybrid trees A data structure with several dimensions for zones with two dimensions. Those hybrid trees aren't going to be able to delegate anything since they use distinct multidimensional data structures. It "consolidates" certain features of both types of document structures, presumably the data distributing (DP) record structure (e.g., R-tree, SS-tree, SRtree) and the perfect space splitting (SP) case (e.g., KDtree, hBtree). The time disperse character of the two over approaches stretches a single data structure throughout complete search execution to roughly $O(n \log(\log n))$.

- Authorship To recall faces in current portraiture or feature successions, revolution invariant multi view face identification (MVFD) employs transformation off plane (ROP) and discretionary rotation-in-plane (RIP) foci. MVFD could be a brutal Face photographs would seldom be upright and frontal unless they are shot appropriately, much as those in the initial stages of scheduled tackling taking care of all supplies. One of the best multi-face locators in the world will be the result of a series of unique methods, such as the Width-First-Search (WFS) tree discoverer structure, the vector Those weak classifiers based on zone packages that take in vector yields may have their computation boosted. While planning, those few components to granular space, and the heulandite pursue a few parts. Similarly, as a subsequent effect, multitier face pointers achieve low computational multifacetedness, broad distinguishment degree, and helter skelter disclosure precision around both standard testing sets and honest-to-goodness portraits. • Author [9] suggested a framework that can use the registration capabilities of mobile devices to continuously extend calculation transformation. As far as the server stack is concerned, consistency domain queries need wireless assistance that may accommodate consistent redesigns. For a couple of discriminating commitments, this satisfies expectations and distinguishes itself from hidden words. At the outset, become In addition to efficiently handling requests for trustworthy domain queries, a distributed server structure is available to partition the whole business territory according to a predetermined plan. This component improves the strength and adaptability of the framework

in the face of changing circumstances, such as when claiming servers. It is possible to use a request-requesting structure to document the inquiry's future refining. These methods essentially reduce the document's size and disperse quality so that in-memory requesting might be improved for little articles with encouraged memory estimation.

3. Hardware Implementation

3.1 Existing System

Children, teenagers, young ladies, the mentally disabled, the elderly with dementia, and so on are all a part of our society on a daily basis. Missing persons are in the hundreds. Despite that, they were sued by the police department. Finding them might be a real challenge at times. The existing procedure requires us to notify the local police station of a person's location if they are reported missing. The police will initiate an inquiry after receiving a complaint by gathering relevant details.

3.2 Proposed System:

We employ RFID technology in our proposed system for identifying missing persons.

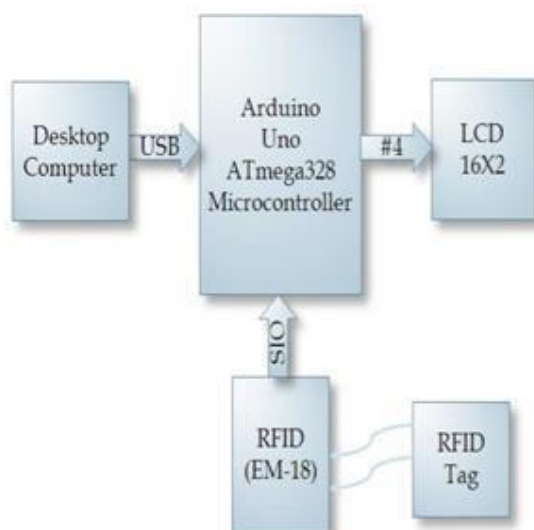

Fig: Block Diagram

Following the presentation and discussion of the components shown in Fig., the following are needed to make this product a reality: an Arduino Uno, an RFID Reader EM-18, RFID Tags, an LCD, a bread board, and a USB-cable. The Arduino Uno The ATmega328-based Arduino Uno is an 8-bit AVR microcontroller board with flash memory and low power consumption. The device has 14 I/O digital pins, 6 analog inputs (with the ability to convert them to PWM outputs), a 16 MHz ceramic

resonator, a USB port, a power connector, an ICSP header, a reset button, and a power jack. All you need is a USB cable, an AC-to-DC converter, or a battery to get it going; it has all the functionality required to support the microcontroller.

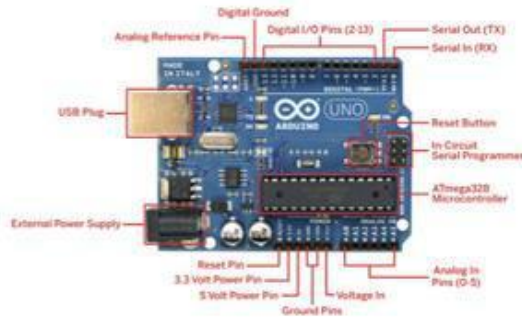

Fig: Arduino Uno Board

RFID Tags The Tag is made up of an antenna and a microchip that stores the identification data. The transceiver, also known as a tag reader, and the tag are able to communicate using radio waves. Radio frequencies carry the identifying information. Active and passive tags are the two main categories. Because the Reader's electromagnetic energy is what powers the passive tags in this application, they are called electromagnetic induction tags. These are inexpensive and often used, as seen in Figure



Fig: RFID tag

The EM-18 RFID Reader; An on-chip antenna and a 5V power source make up the Reader module. A connection is established between the reader module's Tx pin and the microcontroller's Rx pin. Bring the RFID tag up to the reader's scanning range. Currently, the tag is able to connect with the tag reader over radio frequency. Radio frequencies carry the identifying information. After receiving radio frequencies, the reader transforms them into identification data. You may use this tag's identification data for things like LCD displays and other processing. . LCD Screen 16 by 2 One of the many common types of LCD displays is the 16x2 kind. This module was selected because it is budget-friendly, easy to code, and can show any character,

including special and custom ones. It also satisfies the design criteria of 16 characters per line, which is sufficient for the two lines in question. **USB Charging Cable** You may connect your Arduino Uno or any other board to your computer's USB female-A connector with this standard USB 2.0 connection. Using a USB connection, programs may be transferred from a personal computer to the microcontroller's memory. Throughout the testing process, the Arduino will be powered by the PC via USB. It is capable of drawing power from either a 9V battery or an adapter while in use.

4. Conclusions

We designed, tested, and presented an RFID-based system that not only identifies missing people but also shows their name, guardian's name, and contact cellphone number. Fewer hardware components, lower power consumption, and affordable pricing are the product's standout advantages. Finding missing children and elderly people is the primary use case for this technology. Our next step is to inform the public about our RFID missing person identification technology and encourage public events and police stations to think about using it. Finding and returning lost children, disabled youngsters, and elderly people to their legal guardians is one possible use case for this. A person must actually wear the RFID tag for it to work.

REFERENCE

- [1] S. Ayyappan and S. Matilda, "Criminals and missing children identification using face recognition and web scrapping" IEEE ICSCAN 2020.
- [2] Shefali patil, Pratiksha Gaikar, Divya Kare, Sanjay Pawar, "Find missing person using AI", International journal of Progressive Research in Science and Engineering, Vol. 2, No. 6, June 2021.
- [3] Sarthak Babbar, Navroz Dewan, Kartik Shangle, Sudhanshu Kulshreshtra, Sanjeev Patel, "Cross Age Face recognition using Deep Residual Networks ". IEEE 2019 Fifth International Conference on Image Information Processing (ICIIP).
- [4] Bharath Darshan Balar, D S kavya, Chandana M, Anush E, Vishwanath R Hullipalled, "Efficient Face recognition system for identifying lost people", International Journal of engineering and standard technology (IJEAT), ISSN:2249-8958, Volume-8, Issue-5 S, May 2019.

[5] Birari Hetal, Sanyashiv Rakesh, Porje Rohan, Salwe Harish,” Android Based Application-Missing Person Finder”,IREJournals,Volume1Issue12,ISSN:2456-8880.