

AUTOMATIC STREET LIGHT SYSTEM

Dr.P.PRASANNA MURALI KRISHNA⁽¹⁾, Mr.K.Ch.MALLA REDDY⁽²⁾, M
BHANUPRAKASH⁽³⁾, SHAIK JAMEER BASHA⁽⁴⁾, ERLA KESAVA GANESH KUMAR⁽⁵⁾, M
LAKSHMI NARAYANA⁽⁶⁾

^{1,2} *Faculty ECE Department, Krishna Chaitanya Institute of Technology & Sciences-
Markapur, AP, India.*

^{3,4,5,6} *Student, ECE Department, Krishna Chaitanya Institute of Technology &
Sciences, Markapur, AP, India.*

ABSTRACT

The Automatic Street Light System using ESP32, Blynk, External RTC, and Internet Time Synchronization is designed to precisely control streetlight operation based on real-time scheduling. The system synchronizes with NTP (Network Time Protocol) to ensure accurate switching times for turning the lights ON in the evening and OFF in the morning, eliminating seasonal variations. An external RTC module serves as a backup for timekeeping in case of internet failure. Additionally, an LDR (Light Dependent Resistor) is used to monitor the light intensity after the streetlight is turned ON, providing real-time data on illumination levels. The system integrates with Blynk Cloud for remote monitoring of light status and intensity, enhancing automation, reliability, and energy efficiency

I INTRODUCTION

Smart street light systems using IoT technology are the next generation of street lighting systems that offer improved energy efficiency, reduced costs, and better control and management of street lighting. The basic concept of a smart street light system is to incorporate sensors, wireless communication, and intelligent controllers into the street light infrastructure. These smart lights can be programmed to automatically turn on and off based on the surrounding light levels, as well as other factors like pedestrian and vehicular traffic. Additionally, they can be remotely monitored and controlled using IoT technology. IoT technology allows smart street light systems to gather data and feedback on energy consumption, maintenance needs, and other important factors. This data can then be used to optimize the system, improve energy efficiency, and reduce costs. Street lighting is a particularly critical concern for public authorities in developing countries because of its strategic importance for economic and social stability. Inefficient lighting wastes significant financial resources every year, and poor lighting creates unsafe conditions. Energy efficient technologies and design mechanism can reduce cost of the street lighting drastically. Manual control is prone to errors and leads to energy wastage's and manually dimming during mid-night is impracticable. Also, dynamically tracking the light level is manually impracticable. The current trend is the introduction of automation and remote management solutions to control streetlighting [9].

II LITERATURE SURVEY

The concept of smart street lighting systems has gained significant attention in recent years due to their potential to enhance energy efficiency, reduce costs, and improve public safety. Several

studies have proposed various approaches to smart street lighting systems using advanced technologies such as the IoT, artificial intelligence (AI), and sensor networks [1]. Smart street lighting systems have gained significant attention in recent years due to their potential to enhance energy efficiency, reduce costs, and improve public safety. Several studies have proposed various approaches to smart street lighting systems using advanced technologies such as power electronics, wireless sensor networks, and the IoT [2]. The system was able to adjust the brightness of the street lights based on the ambient light level, as well as detect and report any faults in the system. Another study by A. Imran et al. (2019) proposed a smart street lighting system that utilized a combination of IoT, cloud computing, and big data analytics [3].

It is stated that the current traditional street lighting systems are inefficient, as they operate on fixed schedules and are not adaptive to real-time changes in traffic or weather conditions. The literature survey highlights that smart street lighting systems can improve energy efficiency, reduce maintenance costs, and enhance public safety [4]. They discuss various approaches, such as using sensors and wireless communication technologies to monitor and control the street lighting system. They also highlight some of the challenges associated with implementing such systems, including the need for reliable and secure communication protocols and the high cost of installation and maintenance [5]. They discuss various approaches, such as using sensors, wireless communication, and machine learning algorithms, to monitor and control the street lighting system. They also highlight some of the challenges associated with implementing such systems, including the need for reliable and secure communication protocols and the high cost of installation and maintenance [6]. The literature survey in this article discusses various studies related to smart street lighting systems and their applications. It includes research on different sensor technologies used in smart street lighting systems, such as IR sensors, PIR sensors, and ultrasonic sensors. The survey also examines different control strategies for these systems, including manual control, time-based control, and adaptive control. Additionally, the literature survey discusses the benefits of smart street lighting systems, such as energy savings, improved safety, and reduced maintenance costs. The survey also explores the challenges associated with implementing these systems, including the initial cost of installation and the need for technical expertise to maintain and operate the system [7]. The survey examines different sensor technologies used in smart street lighting systems, including IR sensors, PIR sensors, and ultrasonic sensors. Additionally, the literature survey discusses the benefits of smart street lighting systems, such as energy savings, improved safety, and reduced maintenance costs. The survey also explores the challenges associated with implementing these systems, such as the need for technical expertise and the initial cost of installation. Furthermore, the literature survey highlights the importance of using Lab [8].

III EXISTING SYSTEM

The infrared sensors are placed on each side of the road that are used to detect the vehicle movement and send the logics signals to a microcontroller (AT89S52series) to turn on/off the LEDs for a specific distance. Therefore, this way of dynamically switching ON and OFF the street lights helps in reducing the power consumption. The power supply of this project

comprises of step-down transformer, which steps down the voltage from 230v to 12V AC. This is transformed to a DC using a Bridge rectifier. A capacitor is used to remove the ripples using a capacitive filter, and it is then regulated to +5V from 12v using a 7805IC voltage regulator, which is compulsory for the microcontroller as well as other components.

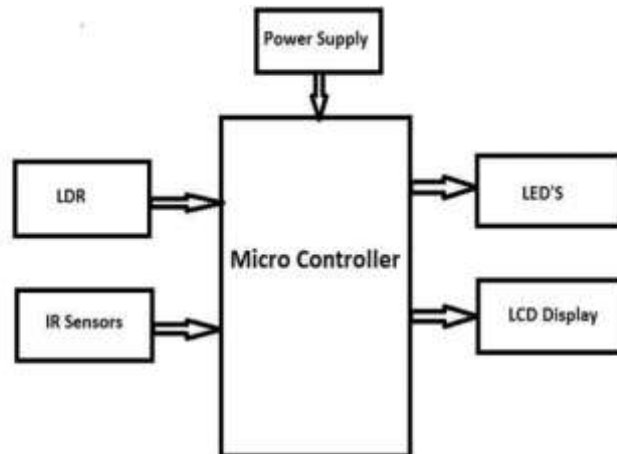

IV PROPOSED METHODOLOGY

Working Principle of the Automatic Street Light System The ESP32-based Automatic Street Light System operates by precisely controlling the ON/OFF timing of streetlights using NTP-synchronized time, with an external RTC module as a backup. The system follows these key steps: Time Synchronization & Control

- The ESP32 connects to the internet and fetches the current time from an NTP server to ensure accurate scheduling.
- If the internet is unavailable, the system relies on the external RTC module to maintain time.
- The system turns ON the streetlight in the evening and OFF in the morning based on predefined time thresholds.
- Light Intensity Monitoring
 - Once the streetlight is turned ON, an LDR sensor continuously measures the ambient light intensity.
 - The ESP32 collects this data and sends it to BlynkCloud, allowing remote monitoring of the illumination level.
- Remote Monitoring via Blynk
 - The Blynk app displays real-time data, including: Streetlight status (ON/OFF)
 - LDR-measured light intensity

BLOCK DIAGRAM

This project is used to detect the movement of a vehicle on highways or roads to turn ON the lights when the vehicle is ahead of the lights, and to turn OFF the glowing light when the vehicle passes away from the lights. By using this project we can conserve energy.

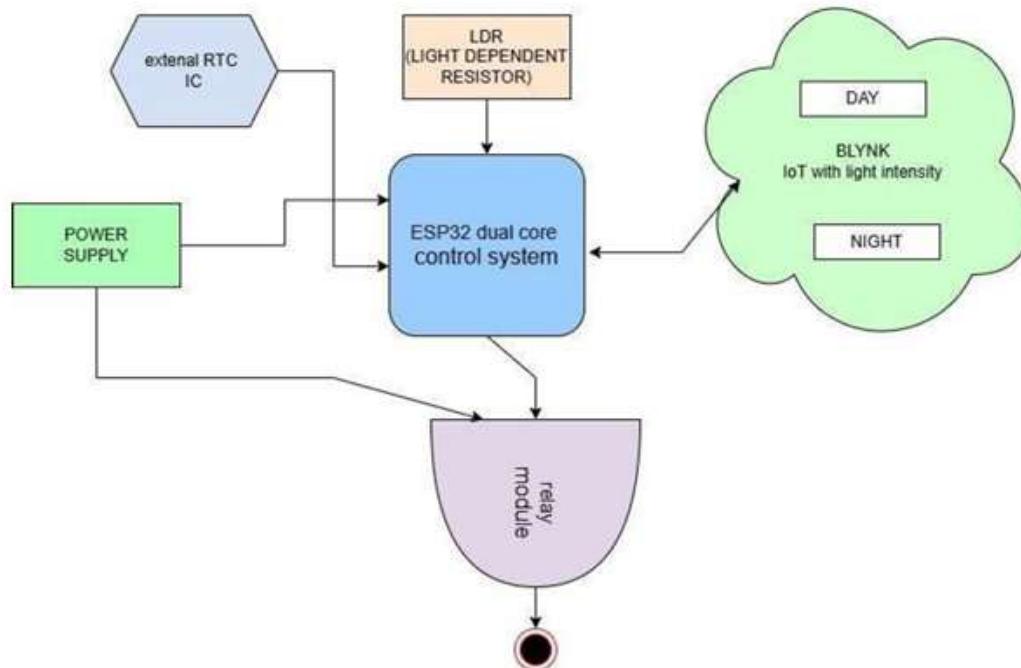

WORKING PRINCIPLE OF THE AUTOMATIC STREET LIGHT SYSTEM

The ESP32-based Automatic Street Light System operates by precisely controlling the ON/OFF timing of streetlights using NTP-synchronized time, with an external RTC module as a backup. The system follows these key steps: Time Synchronization & Control The ESP32 connects to the internet and fetches the current time from an NTP server to ensure accurate scheduling. If the internet is unavailable, the system relies on the external RTC module to maintain time. The system turns ON the streetlight in the evening and OFF in the morning based on predefined time thresholds.

EXPERIMENTAL RESULT

The experimental results of an Automatic Street Light System typically show the following:

- 1. Energy Efficiency:** The system demonstrates significant energy savings as the lights automatically turn on at dusk and off at dawn using sensors (LDR or photodiode). This reduces electricity consumption by only operating when necessary.
- 2. Light Intensity Adjustment:** In more advanced systems, the street light intensity adjusts based on environmental conditions. Results often show the system's ability to increase brightness in low-light conditions and decrease it when there's more ambient light.

3. Cost Reduction: A noticeable reduction in electricity costs, as the system eliminates the need for manual operation, and lights only work during required hours.

4. System Performance: The automatic switching mechanism, driven by light-dependent resistors (LDRs) or other sensors, is typically accurate, with minimal failure rates. The system switches on or off reliably at predefined light intensity levels.

5. Maintenance: Experimental setups typically indicate a reduction in manual intervention for streetlight operation, although regular maintenance of sensors and power components is still required.

6. Real-time Data Monitoring: Some systems provide data monitoring through IoT integration, allowing tracking of power consumption, faults, or failures, enhancing the overall efficiency of the infrastructure.

7. Environmental Impact: Results from experimental implementations show that this system contributes to reducing carbon footprints by cutting down on unnecessary energy usage.

Overall, the experiment usually demonstrates improved sustainability, reduced operational costs, and enhanced energy conservation in public lighting systems.

Advantages of Automatic Street Light System:

1. **Energy Efficiency:** Automatically turns lights on at night and off during the day, ensuring lights are only on when necessary, saving energy.

2. **Cost Savings:** By using less energy, the system reduces electricity bills for municipalities or cities.

3. **Environmental Impact:** Reduces carbon footprint by minimizing unnecessary lighting and energy consumption.

4. **Automation:** Eliminates the need for manual intervention, reducing labor costs and human error.

5. **Improved Safety:** Ensures street lights are on during dark hours, improving visibility and safety for pedestrians and vehicles.

6. **Longer Lifespan of Lights:** Reduced operational time can extend the life of the bulbs, decreasing maintenance and replacement costs.

7. **Smart Integration:** Some systems can integrate with IoT technology for real-time monitoring, diagnostics, and remote control.

Disadvantages of Automatic Street Light System:

1. **Initial Setup Cost:** The installation of sensors and automated systems can be expensive compared to traditional street lighting systems.

2. **Sensor Malfunction:** Light sensors (such as LDRs) may be prone to failure due to weather conditions, dirt, or faulty components, which could disrupt the system.

3. **Dependence on Weather Conditions:** The performance of sensors (like LDRs) may be impacted by factors such as heavy rain, fog, or dust, affecting light timing.
4. **Maintenance:** Though maintenance is generally reduced, the automated system still requires occasional checks and servicing of sensors, wiring, and controllers.
5. **Security Concerns:** If the system relies on wireless communication or IoT, there may be vulnerabilities to cyberattacks or hacking.
6. **Compatibility Issues:** Integrating new automated street lights into existing infrastructure might require additional modifications, adding complexity to the installation process.
7. **Over/Under Lighting in Some Areas:** In cases of faulty sensors or malfunctions, some areas might stay illuminated when unnecessary, while others may not have enough light during dark condition.

V CONCLUSION

This paper was Presently, in the whole world, excessive amount of electric energy is being consumed by the street lamps, which are automatically turned on when it becomes dark and automatically turned off when it becomes blazing. This happens irrespective of the presence or absence of people on the streets saving manual effort and power to certain extent. None the less, unnecessary wastage of energy being consumed by the lamps in the absence of people on the street could be taken care saving power energy to the larger extent. Hence, in this paper a smart streetlight system is proposed using IoT technology. In this, lights would be on with full intensity when people are detected otherwise lights would be switched on with min intensity or switched off. In our paper we design a system which uses IoT technology.

VI REFERENCES

1. Lee, J.; Baik, S.; Lee, C. Building an Integrated Service Management Platform for Ubiquitous Cities. *Computer* 2011, 44, 56–63.
2. Li, Z.; Chen, C.; Wang, K. Cloud Computing for Agent-Based Urban Transportation Systems. *IEEE Intell. Syst.* 2011, 26, 73–79.
3. Mitton, N.; Papavassiliou, S.; Puliafito, A.; Trivedi, K.S. Combining Cloud and sensors in a smart city environment. *EURASIP J. Wirel. Commun. Netw.* 2012, 2012, doi:10.1186/1687-1499-2012-247.
4. Bonomi, F.; Milito, R.; Zhu, J.; Addepalli, S. Fog Computing and Its Role in the Internet of Things. In Proceedings of the First Edition of the MCC Workshop on Mobile Proceedings of the First Edition of the (MCC'12), Helsinki, Finland, 13–17 August 2012; pp. 13–16.
5. Fox, G.C.; Hartman, R.; Kamburugamuva, S. OpenSourceIoTCloud. Available online: <https://sites.google.com/site/opensourceiotcloud> (accessed on 1 July 2015).
6. Fox, G.; Kamburugamuve, S.; Hartman, R. Architecture and measured characteristics of a cloud based internet of things. In Proceedings of the 2012 International Conference on Collaboration Technologies and Systems (CTS), Denver, CO, USA, 21–25 May 2012; pp. 6–12.

7. CloudComputing(MCC'12),Helsinki,Finland,13–17August2012;pp.13–16.
8. Li, F.; Voegler, M.; Claessens, M.; Dustdar, S. Efficient and Scalable IoT Service Delivery onCloud. In Proceedings of the 2013 IEEE Sixth International Conference on Cloud Computing(CLOUD),SantaClara,CA,USA, 28June–3July2013;pp.740–747.
9. Hwang,K.;Dongarra,J.;Fox,G.C.Distributed .and Cloud Computing:From Parallel Processing to the Internet of Things, 1st ed.; Morgan Kaufmann Publishers Inc.: San Francisco,CA, USA, 2011. LogMeIn, I. Xively. 2015. Available online: <https://xively.com/> (accessed on 1July2015).
10. PTC. ThingWorx—Internet of Things and M2M Application Platform. Available online :<http://www.thingworx.com/>(accessedon1July2015).
11. SmartThings,Inc.SmartThingsOpenCloud.Availableonline:<http://www.smarth>