

## IOT BASED HEALTH MONITORING SYSTEMS

Dr.P.PRASANNA MURALI KRISHNA<sup>(1)</sup>, Mr.K.Ch.MALLA REDDY<sup>(2)</sup>, M BHANUPRAKASH<sup>(3)</sup>,  
SHAIK JAMEER BASHA<sup>(4)</sup>, ERLA KESAVA GANESH KUMAR<sup>(5)</sup>, M LAKSHMI NARAYANA<sup>(6)</sup>

<sup>1,2</sup> Faculty ECE Department, Krishna Chaitanya Institute of Technology & Sciences-Markapur, AP, India.

<sup>3,4,5,6</sup> Student , ECE Department, Krishna Chaitanya Institute of Technology & Sciences,Markapur, AP,  
India.

### ABSTRACT

The Internet of Things (IOT) has been widely used to interconnect the available medical resources and offer smart, reliable, and effective healthcare service to the elderly people. Health monitoring for active and assisted living is one of the paradigms that can use the IOT advantages to improve the elderly lifestyle. In this project, we present an IOT architecture customized for healthcare applications. The proposed architecture collects the data and sent to the cloud where it is processed and analyzed. Feedback actions based on the analyzed data can be sent back to the user. Aprototype of the proposed architecture has been built to demonstrate its performance advantages.

Now a days with tons of new healthcare technology start-ups, IOT is rapidly revolutionizing the healthcare industry. In this project, we have designed the IOT Based Patient Health Monitoring System using Node MCU ESP8266. The IOT platform used in this project is Thing Speak. Thing Speak is an open-source Internetof Things (IOT) application and API to store and retrieve data from things using the HTTP protocol over the Internet or via a Local Area Network. This IOT device could read the pulse rate and measure the surrounding temperature. It continuously monitorsthe pulse rate and surrounding temperature and updates them to an IOT platform.

### INTRODUCTION

In the rural areas, as of our survey, there's a scarcity of proper health treatments for the people, and that they don't find the proper quality of treatment. Widely, people get the treatment after the disease has affected their body to the where it gets very critical. Mean while, while considering the value of treatment also many of the agricultural people, mostly farmers cannot afford it. Thus, to act as a much easier treatment process, we have designed our project in a minimalistic form but much more effective. This project is meant to offer a major param eter to diagnose the disease. The Internet of Things (IoT) is rapidly growing attention not only in certain fields but much more, especially in personalized healthcare [1–5]. Medical scientists and researchers, work hard within the field of innovation and research for many decades to urge better health services and happiness in human lives [6,7].

### LITERATURE SURVEY

The literature review of the paper that were referenced and those that serves the base paper and supporting paper which provides the clear idea of the healthcare system and machine learning algorithms and proper method of recommendations. Shoban Babu et al. [8] has put forward a concept where a patient's health is

monitored efficiently with the help of IoT. It is primarily used to discover a patient's disorder and it provides a suitable remedy for the recovery of patient's health. IoT also helps in alarming the peers in the event of sensing an abnormality by the help of various sensors setup. Sreekanth et al. [9] discuss on collection and transferring of a data in the cloud. The sensed data is then processed by the microcontroller however there is no proper method to send the data or to classify the data according to the patients. Wan et al. [10] has designed the IoT Based Patient Health Monitoring System. In this, the wireless sensors from different parts of the body are interlinked to the node and then connected to the server. But the downside of this work is that the sensors are wireless and the data derived across the sensors can be uncertain. Valsalan P et al. [11] used only Arduino to operate the data which collects data across the sensors and these are stored and then transferred to the database to access them for future purpose. They didn't create a EMR profile for patients, which is used to record the patient's information that can be easily accessed by anyone. Yeri V et al. [12] proposed an idea about monitoring the body condition of the patients from anywhere in the world. But they didn't use RFID tag for the sensors to collect the patient's body information in a particular manner. The main drawback is that the data across the sensors which is transferred to the database is not proper and it's difficult to access them at any instant of time and lack of documentation

## PROPOSED METHODOLOGY

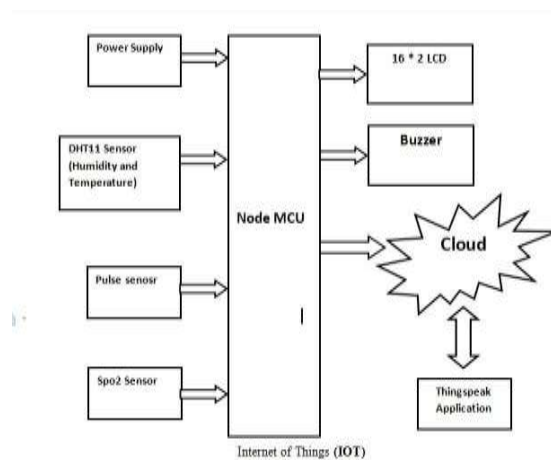

## IOT

The Internet of Things (IOT) refers to the use of intelligently connected devices and systems to leverage data gathered by embedded sensors and actuators in machines and other physical objects. IOT is expected to spread rapidly over the coming years and this convergence will unleash a new

dimension of services that improve the quality of life of consumers and productivity of enterprises, unlocking an opportunity that the GSMA refers to as the 'Connected Life'. For consumers, the IOT has the potential to deliver solutions that dramatically improve energy efficiency, security, health, education and many other aspects of daily life.

## **APPLICATIONS**

### **Internet of Things industry sector categories**

For consumers, connectivity provided by the IOT could enhance their quality of life in multiple ways, such as, but not limited to, energy efficiency and security at home and in the city. In the home, the integration of connected smart devices and cloud-based services will help address the pressing issue of energy efficiency and security. Connected smart devices will enable a reduction in utility bills and outages, while also improving home security via remote monitoring.

- IOT smart cities applications
- IOT health applications
- IOT education applications
- IOT productivity applications

## **ADVANTAGES**

The IOT will increase the range of services, each requiring varying levels of bandwidth, mobility and latency. For example, services that are related to public safety or personal safety will generally require low latency, but not high bandwidth per sec. alternatively, services that provide surveillance might also require high bandwidth. Due to the differing level of service demand, mobile networks may need the ability to identify the service which is generating traffic and meet its specific needs. For example, alert services related to public safety or personal health would require a higher priority compared to metering information, which is a normal monitoring activity. Varying levels of mobility (the degree to which devices and applications need to be nomadic) is another important characteristic of IOT service demand. For nomadic services, location information and Geo-fencing becomes a crucial enabler. stakeholders to collaborate more effectively in order to propel the market forward for the benefit of consumers and society.

## ESP8266 Node MCU

The ESP8266 is the name of a micro controller designed by Express if Systems. The ESP8266 itself is a self-contained WiFi networking solution offering as a bridge from existing micro controller to WiFi and is also capable of running self-contained applications.

### Specifications

- Voltage:3.3V.
- Wi-Fi Direct (P2P), soft-AP.
- Current consumption: 10uA~170mA.
- Flash memory attachable: 16MB max (512K normal).
- Integrated TCP/IP protocol stack.
- Processor: Ten-silica L106 32-bit.
- Processor speed: 80~160MHz.
- RAM: 32K + 80K.
- GPIO's: 17 (multiplexed with other functions).
- Analog to Digital: 1 input with 1024 step resolution.
- +19.5dBm output power in 802.11b mode
- 802.11 support: b/g/n.
- Maximum concurrent TCP connections: 5.

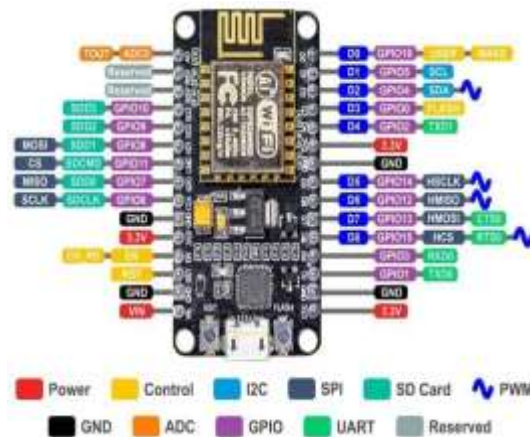
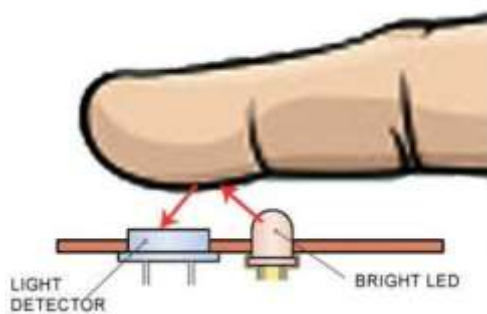

FIG:Node MCU Pin Diagram

**Pulse Sensor and SP02 Sensor:**

Heart beat sensor is designed to give digital output of heart beat when a finger is placed on it. When the heart beat detector is working, the beat LED flashes in unison with each heart beat. This digital output can be connected to micro controller directly to measure the Beats Per Minute (BPM) rate. It works on the principle of light modulation by blood flow through finger at each pulse.



**LCD (Liquid Cristal Display):**

A liquid crystal display (LCD) is a thin, flat display device made up of any number of color or monochrome pixels arrayed in front of a light source or reflector. Each pixel consists of a column of liquid crystal molecules suspended between two transparent electrodes, and two polarizing filters, the

axes of polarity of which are perpendicular to each other. Without the liquid crystals between them, light passing through one would be blocked by the other. The liquid crystal twists the polarization of light entering one filter to allow it to pass through the other.

A program must interact with the outside world using input and output devices that communicate directly with a human being. One of the most common devices attached to an controller is an LCD display.

**EXISTING METHOD:**

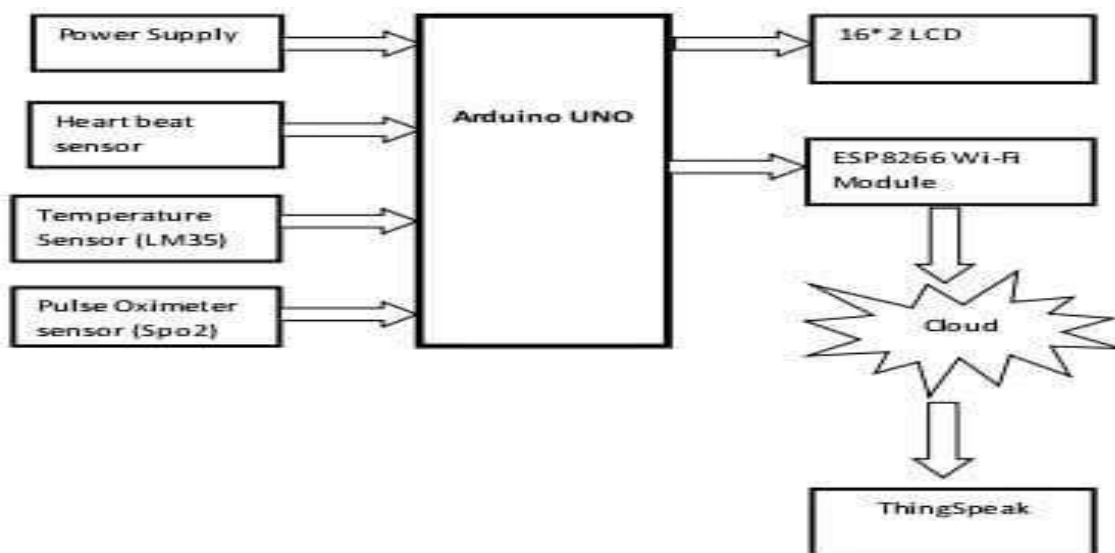

In a hospital, either the nurse or the doctor has to move physically from one person to another for health check which may not be possible to monitor their conditions continuously.

Thus, any critical situations cannot be found easily unless the nurse or doctor checks the person's at that moment. This may be a strain for the doctors who have to take care of a number of people in the hospital.

**PROPOSED SYSTEM:**

In a hospital, either the nurse or the doctor has to move physically from one person to another for health check which may not be possible to monitor their conditions continuously.

To overcome the drawbacks of the existing system, the proposed system has been evolved.

Our proposed system uses Arduino with ESP8266 to send data from sensors to cloud platform that is thing speak. Any number of users can see the medical record recorded on the thing speak using the thing speak access key.

Our system continuously monitoring patient's vital signs and sense abnormalities. Bridging the gap between doctor and the patients.

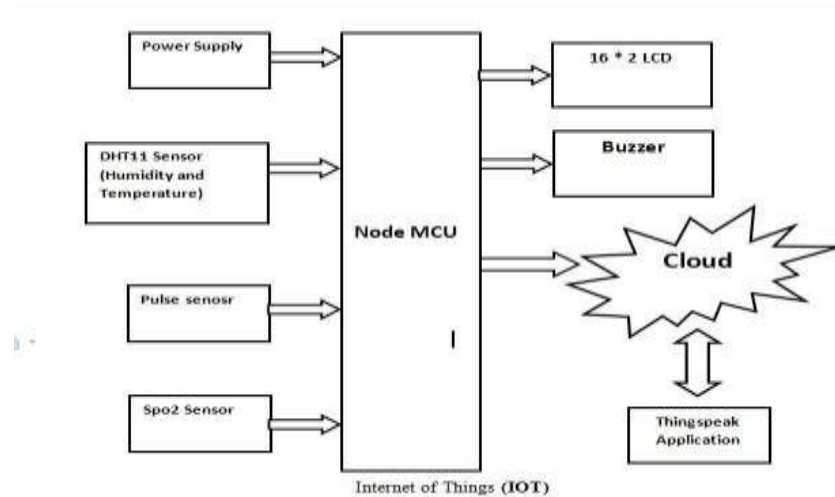

## RESULTS



FIG 1:TEMPERATURE SENSOR



FIG 2:HUMIDITY SENSOR



FIG 3:HEART BEAT SENSOR



FIG 4 :PULSE OXIMETER SENSOR



## CONCLUSION

The results of the project is observed in chart format, these values might not precise to the original values but they meet the standards of each respective fields. Evaluation from these results helps to determine the health condition of the patients. The project module of Remote health Monitoring has been effective in monitoring health conditions. It helps everyone in daily routine of health consciousness.

It helps in measuring health condition from a toddler to an older person. This module minimizes time of patient and reduces hospital visiting's and also gives a friendly experience with all kinds of sensors. The main aim of this project is to make it mobile and to provide an easy place to accommodate in homes. Futuristic scope to the present are often a combined unit which acquires less space and is simpler to work in any environmental conditions and not affecting the results specially in outdoor monitoring.

## REFERENCES

[1] Mohamed Abel-Basset Ab-do, "Structural Health Monitoring, History, Applications and Future. A Review Book," Edition First, ISBN 978-1-941926-07-9, January 2014.

- [2] Amandeep Kaur, Ashish Jasuja, "Health Monitoring Based on IoT using RASPBERRY PI" International Conference on Computing, Communication and Automation (ICCCA2017), ISBN:978-1-5090- 6471-7/17/ ©2017 IEEE
- [3] M.Shamim Hossaina Ghulam Muhammad "Cloud-assisted Industrial Internet of Things (IIoT) – Enabled framework for health monitoring".
- [4] Shyamal Patel "A review of wearable sensors and systems with application in rehabilitation" Journal of Neuro Engineering and Rehabilitation Northeastern University.
- [5] S. M. Riazul Islam UWB Wireless Communications Research Center, Inha University, Incheon, Korea The Internet of Things for Health Care: A Comprehensive Survey
- [6] E. GELOGO JIN WOO PARK SCH. "Internet of Things (IoT) Driven U-healthcare System Architecture".
- [7] Suhas Kale and C. S. Khandelwal "Design and implementation of real time embedded tele-health monitoring system" international conference on circuits, power and computing technologies, 2013.
- [8] V. Tripathi and F. Shakeel, "Monitoring Health Care System Using Internet of Things - An Immaculate Pairing," 2017 International Conference on Next Generation Computing and Information Systems (ICNGCIS), Jammu, 2017, pp. 153-158.

- [9] M. Hamim, S. Paul, S. I. Hoque, M. N. Rahman and I. Bargee, "IOT Based Remote Health Monitoring System for Patients and Elderly People," 2019 International Conference on Robotics,Electrical and Signal Processing Techniques(ICREST), Dhaka, Bangladesh, 2019, pp. 533-538.
- [10] Luca Catarinucci, Danilo de Donno, Luca Mainetti, Luca Palano, Luigi Patrono, Maria Laura Stefanizzi, and Luciano Tarricone. "An IoT-Aware Architecture for Smart Healthcare Systems". IEEE JOURNAL, Dec 2015.
- [11] A.M. Ghosh, D. Halder and SK.A. Hossain, "Remote Health Monitoring System through IoT" 5th (ICIEV),2016.
- [12] R.T. Hameed, O. Abdulwahabe and M. N. ġăpuú "Health Monitoring System Based on Wearable Sensors and Cloud Platform" 20th (ICSTCC), October 13- 15,2016.
- [13] A. Abdullah, A. Ismael, A. Rashid, A. Abou-ElNour, and Mohammed Tarique "Real time wireless health monitoring application using mobile devices" (IJCNC) Vol.7, No.3, May 2015.
- [14] N.P. Kumari and V. Yadav "Heart Rate Monitoring and Data Transmission via Bluetooth" International Journal of Innovative and Emerging Research in Engineering Volume 2, Issue 2, 2015.
- [15] M.M. Lambat and S C Wagaj, "Health Monitoring system", International journal of science and research, Vol 4, 2015.
- [16] ]R. Wahyu Kusuma, I. Ridha, Y. Rianto and E.P. Swelandiah, "FPGA based heartbeats monitor with fingertip optical sensor" (IJCSEIT), Vol. 4, No.5, October 2014.
- [17] E.L. Verma and J. Bagga "Design and Implementation of Online Heart Rate Monitoring System" (IJSR) ISSN (Online): 2319-7064 Index Copernicus Value(2013): 6.14 Impact Factor (2014): 5.611.