

IOT BASED SMART PARKING MANAGEMENT SYSTEM

Mr.D.SATYANARAYANA ⁽¹⁾, Mr.M.RAMANA REDDY⁽²⁾, PASUPULA SWATHI⁽³⁾, SHAIK JAMEER BASHA⁽⁴⁾, KUNDURU SUBHASHINI⁽⁵⁾, RODDA VASANTHA KUMARI⁽⁶⁾

^{1,2} Faculty ECE Department, Krishna Chaitanya Institute of Technology & Sciences-Markapur, AP, India.

^{3,4,5,6} Student , ECE Department, Krishna Chaitanya Institute of Technology & Sciences,Markapur, AP, India.

ABSTRACT

In recent times the concept of smart cities have gained grate popularity. Thanks to the evolution of the Internet of things the idea of smart city now seems to be achievable. Consistent efforts are being made in the field of IoT in order to maximize the productivity and reliability of urban infrastructure. Problems such as, traffic congestion, limited car parking facilities and road safety are being addressed by IoT. In this paper, we present an IoT based cloud integrated smart parking system. The proposed Smart Parking system consists of an on-site deployment of an IoT module that is used to monitor and signalize the state of availability of each single parking space. A mobile application is also provided that allows an end user to check the availability of parking space and book a parking slot accordingly. The paper also describes a high-level view of the system architecture. Towards the end, the paper discusses the working of the system in form of a use case that proves the correctness of the proposed model.

I INTRODUCTION

An embedded system is a system which is going to do a predefined specified task is the embedded system and is even defined as combination of both software and hardware. A general-purpose definition of embedded systems is that they are devices used to control, monitor or assist the operation of equipment, machinery or plant. "Embedded" reflects the fact that they are an integral part of the system. At the other extreme a general-purpose computer may be used to control the operation of a large complex processing plant, and its presence will be obvious

OBJECTIVE OF PROJECT:-

As the world is becoming smarter day-by-day, Every service is becoming faster, people spend much time searching the slot in parking or finding their vehicle in parking place. Many accidents and damages occur in parking place itself. To overcome these problems , We have developed the project IOT BASED SMART PARKING MANAGEMENT SYSTEM

This project enables the user to find the vacant slot in the entrance itself or can search the slot in mobile app or website. WE also provide reserved slots and the entry of vehicle is verified by scanning the RFID tag. We register the vehicle using details of its RFID tag and the entry is protected with RFID Reader. Only when the details of vehicle matches with registered details, The vehicle can enter the parking. This

also provides security for vehicles using less Manpower(mostly automation). The no.of Reserving slots vary between different versions i.e., Apartments, Multiplex, Hospitals, etc...

II LITERATURE SURVEY

Smart Parking technology is leading the way in the delivery of proven, fully integrated, end-to-end solutions, resulting in a transformation of the complete parking experience.

Robin Grodi et.al [1] has done that how the vehicle will occupy in the particular allocated place. RFID sensors detect the presence of a vehicle or other objects. Once a vehicle is detected, the system needs a way to notify drivers or a parking spot being occupied. The disadvantage is, the parking place will be detected only to the nearby places there is no GPS sensor to search the parking slots from the far place.

Alirezahassani et.al [2] had implemented this system using a mobile application that is connected to the cloud. The user will set the time for when he is going to allocate the place. If he didn't occupy later the alarm will be given to the user. The app will show the number of allocated and the empty spaces in the parking slots. The disadvantage is, after allocating if another user request for the same place then he is unable to allocate that place so it is the waste of space if the first user cancel later, waste of time and money.

DharminiKanteti et.al [3] have developed a Smart Parking System In the case of pre-registered users IP cameras would capture the vehicle registration number and they can proceed without interruptions. As per their details like parking time estimate, their place of visit etc. For preregistered users, the amount will be deducted from E- wallet and there by users will be notified. A similar pricing system will be followed for new users but the payment is offline. The disadvantages is, the system could serve all the parking requests but beyond 80 it couldn't accommodate more cars since the parking is full.

III EXISTING SYSTEM

The existing system provides only showing the empty slots and allowing the vehicles if slots are available.

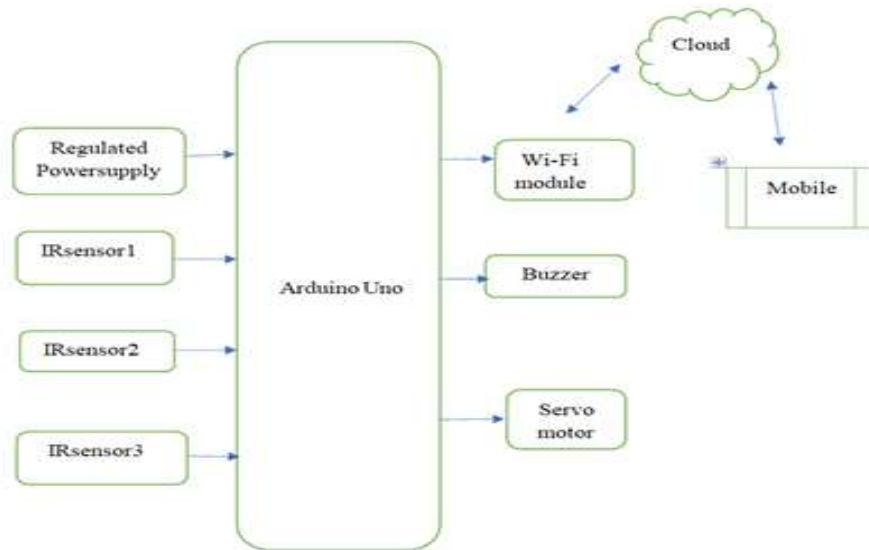

IV PROPOSED METHOD

Block diagram

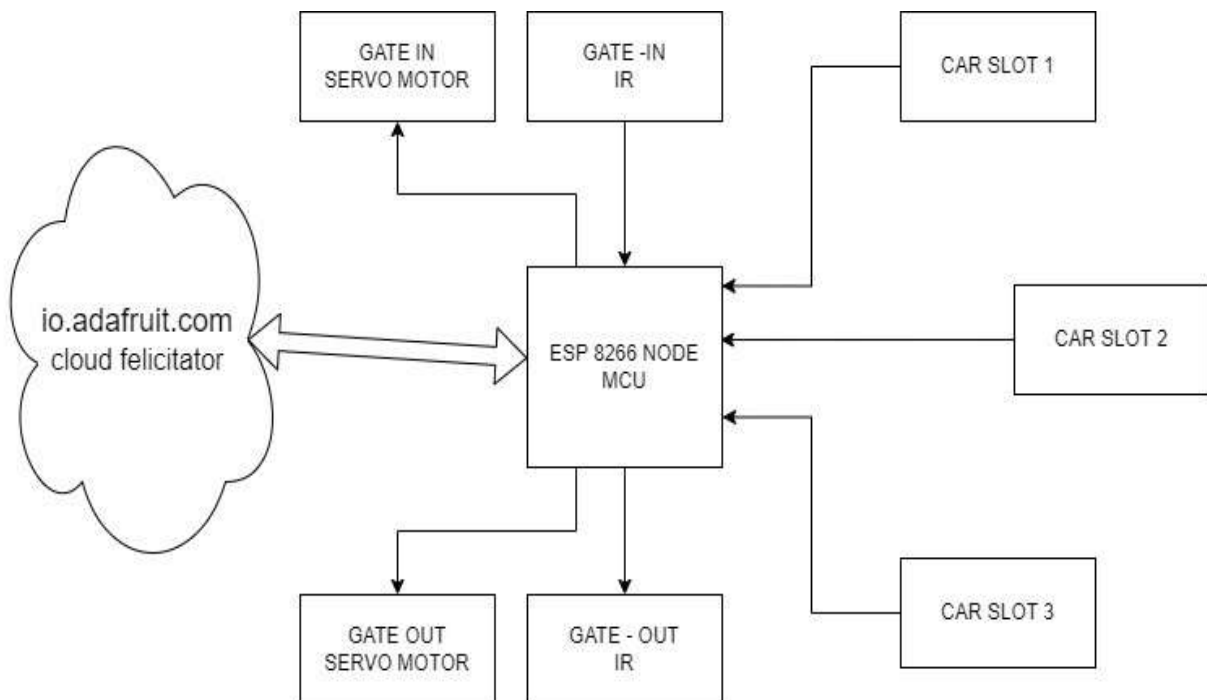

WORKING PRINCIPLE

This paper is an RFID-based access control system integrated with an ESP32 microcontroller, IR sensors, and a servo motor. The ESP32 acts as the central processing unit, managing communication between the RFID module (RC522), IR sensors, and the servo motor. When an RFID tag or card is brought near the RFID reader, it scans the unique identification number (UID) and sends it to the ESP32 for authentication. If the ID matches a pre-authorized list, the ESP32

triggers the servo motor to open a door or gate. The IR sensors are likely used for object detection or additional security, ensuring the system can detect movement or verify user presence before granting access. A buck converter is included to regulate the voltage supply, ensuring stable operation of the components. This setup is commonly used for smart security systems, automated entry gates, or restricted access areas, combining RFID authentication with sensor-based automation for enhanced security and efficiency.

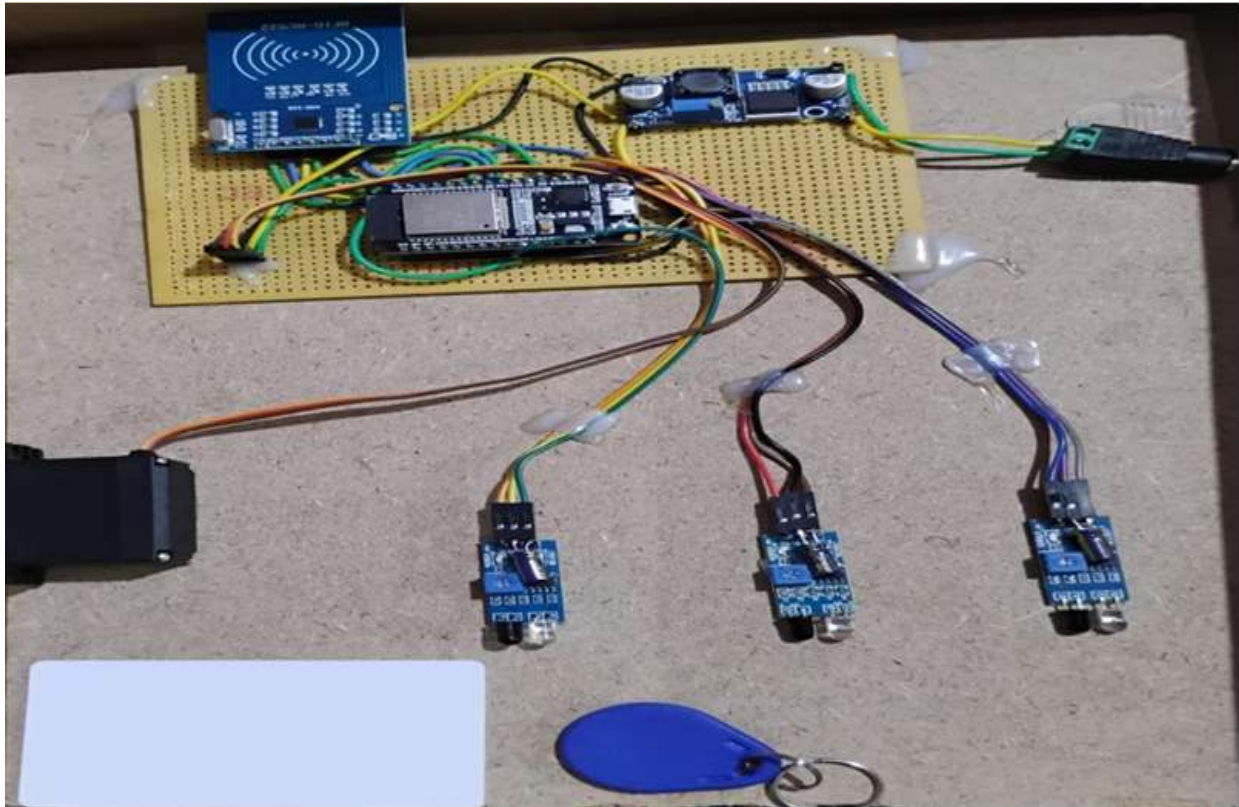

APPLICATIONS:

- 1) Provides a parking slot .
- 2) It can be implemented in commercial buildings like shopping malls, theaters etc.
- 3) Provides tools to optimize workspace management.
- 4) Simplifies the parking experience of stakeholders.
- 5) Optimize parking space uses.

V CONCLUSION

This paper provides an efficient way of parking system which can be used in multiple versions like Apartments, Multiplex, Hospital etc. The problems which would arise while working with smart parking system as well as the solutions has been described which gives a good platform for all the users. With the implementation of smart parking system, it assures the ease of life for individuals who struggle in daily routines of their day to day life. The system that we propose provides real time information regarding availability of parking slots in a parking area.. So the users can save their time from searching for parking slots.

FUTURESCOPE

This project can be developed further to get better results. Database is used to store the details of RFID tag and enables the — FIND MY VEHICLE| option, which enables users to find vehicle and its parking slot details by using RFID tag which protects costumer's Privacy. We can develop a user interface and correlate all the parking places under single interface (either app or website) where a user can able to search for a vacant slot in particular parking area, can also utilize FIND MY VEHICLE , can also enable slot booking system based on time variant.

IV REFERENCES

- [1] Robin Grodi, Danda B. Rawat, Fernando Rios-Gutierrez: Smart parking-parking occupancy monitoring and visualization system for smart cities.
- [2] Abhirup Khanna, Rishi Anand: Io T based smart parking system.2016 International conference on Internet of Things and application(IOTA).
- [3] Dharmini Kanteti, D V S Srikar and T K Ramesh: smart parking system for commercial stretch in cities.
- [4] Georgios Tsaramirsis, Ioannis Karamitsos, Charalampos Apostolotopoulos: smart parking-an Io T application for smart cities.
- [5] Rosario Salpietro, Luca Bedogni, Marco Di Felice, Luciano Bononi: Park here! A smart parking based on smart phones' embedded sensors and short range communication technologies
- [6] Julian Timpner, Lars Wolf, "A Back-end System for an Autonomous Parking and Charging System for Electrical Vehicles", International Electrical Vehicle Conference Greenville, SC.

- [7] Manjusha Patil, Vasant N. Bhojge, “Wireless Sensor Network and RFID for Smart Parking System”, International Journal of Engineering Technology and Advanced Engineering, Volume 3, Issue 4, April 2013, 30 IJETAE.
- [8] Mehmet Sukru Kuran, Aline Carneiro Viana, Luigi Iannone, Daniel Kofman, Gregory Mermound, Jean P. Vasseur, “A Smart Parking Lot Management System for Scheduling the Recharging of Electric Vehicles”, IEEE Transaction on Smart Grid November 2015.
- [9] Morris Kesler, “Wireless Charging of Electrical Vehicles”, WiTricity Corporation.
- [10] Nazish Fatima, Akshaya Natlkar, Pratiksha Jagtap, Snehl Chooudhari, “IoT Based Smart Car Parking System for Smart Cities”, International Journal of Advance Research, Ideas and Innovations in Technology, Vol. 4, Issue 1, 2018.
- [11] Sahil Rupani, Nishant Doshi, “A review on smart parking using internet on things (IOT)”, The 3rd International Workshop on Recent advances on Internet of Things: Technology and Application Approches (IoT-T&A 2019) Nov 2019, Coimbra, Portugal.
- [12] Shital khutwad, Shruti Gaur, “Wireless Charging System for Electric Vehicles”, International conference on Signal Processing, Communication, Power and Embedded System (SCOPEs), 2016.IEEE
- [13] Songyan Niu, Haiqi Xu, Zhirui Sun, Z. Y. Shao, Linni Jian, “The State of The Arts of Wireless Electrical Vehicle Charging via Magnetic Resonance: Principles, Standards and Core Technologies”, Journal of Renewable and Sustainable Energy Reviews, 2019 USA IEEE 2012 Watertown, MA, USA, 2018. IEEE
- [14] Zhe Wei, Yue Li, Yongmin Zhang, Lin Cal, “Intelligent Parking Garage EV Charging Scheduling Considering Battery Charging Characteristic”, IEEE Transaction on Industrial Electronics, Vol 65, 3 March 2018