

AUTOMATIC RAILWAY GATE SYSTEM

Dr.P.PRASANNA MURALI KRISHNA⁽¹⁾, Dr.A.RANGANAYAKULU⁽²⁾, Mrs.N.SWARUPA RANI⁽³⁾, GUMMA KALYAN⁽⁴⁾, BADDITI MAHESH BABU⁽⁵⁾, RACHARLA CHINNA BRAHMAIAH⁽⁶⁾

^{1,2,3} Faculty ECE Department, Krishna Chaitanya Institute of Technology & Sciences- Markapur, AP, India.

^{4,5,6} Student, ECE Department, Krishna Chaitanya Institute of Technology & Sciences, Markapur, AP, India.

ABSTRACT

The automatic railway gate system is an essential safety measure that helps to prevent accidents at railway crossings. In this project, we will be using two types of sensors, IR Sensor and Ultrasonic Sensor, along with a servo motor and a buzzer to design the automatic railway gate system. The IR sensor will be used to detect the approaching train, while the ultrasonic sensor will be used to detect the presence of obstacles in the way of the gate. The proposed system will provide a reliable and efficient solution for ensuring the safety of railway crossings by automating the gate closing and opening process, which is currently manually operated in many locations. An automatic railway gate system is a safety system that ensures the protection of railway crossings from accidents. The system uses sensors and microcontrollers to detect the arrival of trains and automatically close the gates to prevent vehicles and pedestrians from crossing the railway tracks. The system also has alarms and warning signals to alert the road users about the approaching trains. The advantages of an automatic railway gate system include reducing the chances of accidents and saving the lives of people who cross the railway tracks. This system can be implemented in both rural and urban areas to enhance safety on the roads and railways.

I LITERATURE SURVEY

At present scenario, in the level crossing line the railway gate is operated normally by a gate keeper. This happen when the railway line is cross over the road and there is a gate that have to be controlled. The gate keeper works after receiving the information about the train arrival from the nearer station. When the train starts to leave the station, the particular station delivers the information to give the signal for gatekeeper to get ready. This is the operation are followed for operating the railway gates. In addition, this automatic railway gate system can contribute a lot of benefit either to the road user or to the railway management. This type of gate can be implementing in the level crossing where the chances of accidents are higher. The computer integration will be used to provide addition in the latest technology. This invention relates to improvements in automatically operated railway, crossing gates. The primary object of this invention the provision of an automatically operated railway crossing gate which may effectively control traffic at grade crossings, to highway traffic which is within the zone of the intersection to proceed to safety, and at the same time

preventing advancing high way traffic from-entering the zone of the intersection during an approach of a train or other vehicular traffic on the railway. This invention relates particularly to an electric safety gate system for use at railway crossings, and which will automatically operate to swing a gate across the roadway in an obstructing and warning position at the approach of train the device being so designed as to be controlled in its operation by approaching trains, without the necessity or the presence of a watch man, at the railway crossing, and in a manner to insure that the gate will automatically close a predetermined interval before the train reaches the crossing, irrespective of whether or not the train is traveling at a high rate of speed or at a low rate of speed. The structure further embodying means for 'automatically opening the gate when the train has passed.

This invention relates to automatic railway crossing gates and more particularly to a gate operating mechanism controlled by trains approaching a grade crossing for operating the gates to lower them upon the approach of the train and to raise them after the train has passed. An important object of the invention is to provide a novel form of control mechanism for effecting automatic lowering of the gates at a rail road grade crossing upon the approach of a train.

II EXISTING METHOD:

In general, the railway gate mechanism with a gatekeeper is a system used at railway crossings where the gates are manually operated by a gatekeeper. The gatekeeper's role is to ensure that the gates are closed and opened at the appropriate times to allow the safe passage of trains and vehicles. The mechanism typically includes a signal system that alerts the gatekeeper when a train is approaching. The gatekeeper then manually closes the gates to prevent any vehicles or pedestrians from crossing the tracks. Once the train has passed, the gatekeeper opens the gates again to allow traffic to cross. The gatekeeper plays a critical role in ensuring the safe operation of the railway gate system. They must be vigilant in monitoring the approach of trains and vehicles and ensure that the gates are opened and closed at the appropriate times. Proper training and communication between the gatekeeper and the train conductor are essential to ensure the safe passage of trains and vehicles. While the manual railway gate system with a gatekeeper may be less common than automatic systems, it is still used in many parts of the world, particularly in rural areas where there is less traffic

Disadvantages :

- **Traffic congestion:** When the gates are closed to prevent vehicles from crossing the tracks, it can cause traffic congestion, particularly during peak hours. This can lead to delays and frustration for motorists.
- **Malfunction:** Like any mechanical system, the normal railway gate system is subject to malfunction. If the gates fail to close or open properly, it can cause accidents and disruptions to train schedules.
- **Cost:** The installation and maintenance of railway gate systems can be expensive. This can be a significant burden for smaller communities or rural areas where there may be fewer crossings.

- Inefficient: In some cases, the normal railway gate system can be an inefficient safety measure. For example, it may not be the best option for crossings with low traffic volume or where visibility is good.
- Lack of awareness: Pedestrians and motorists may not always be aware of the dangers posed by railway crossings, particularly in areas with low traffic volume. This can lead to accidents and fatalities.

III PROPOSED METHOD

- The automatic railway gate system is implemented to enhance the safety of railway crossings and to reduce traffic caused by the manual operation of railway gates.
- The system is designed to automate the process of opening and closing railway gates, which helps to reduce the risk of accidents caused by human error or negligence.
- The proposed system will provide a reliable and efficient solution for ensuring the safety of railway crossings by automating the gate closing and opening process.

BLOCK DIAGRAM OF PROPOSED SYSTEM

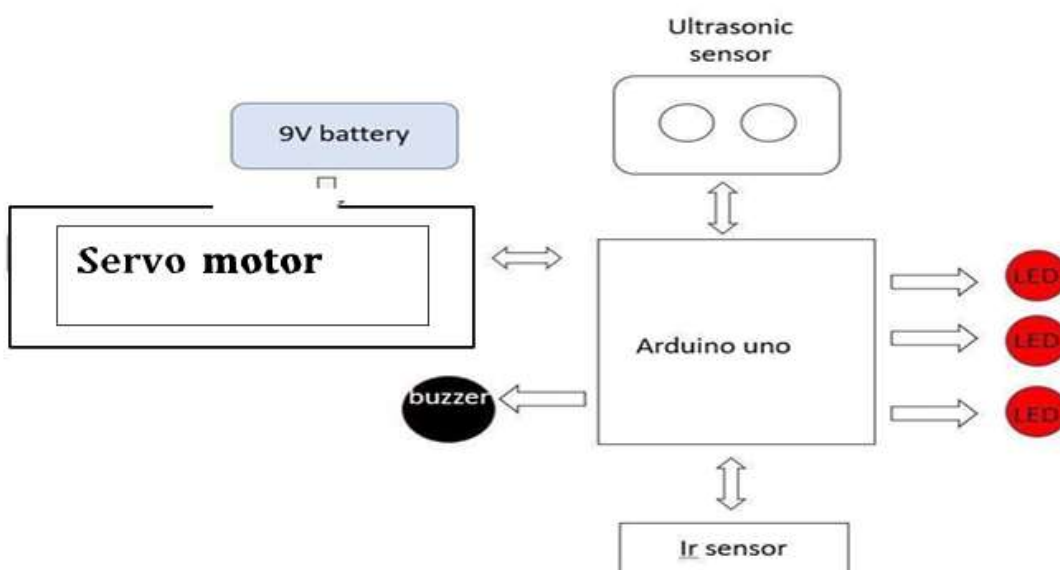

WORKING: In this paper, we will be using two types of sensors, IR Sensor and Ultrasonic Sensor, along with a servo motor and a buzzer to design the automatic railway gate system. The IR sensor will be used to detect the approaching train, while the ultrasonic sensor will be used to detect the presence of obstacles in the way of the gate. Once the IR sensor detects the approaching train, the servo motor will be activated to close the gate, and the buzzer will be sounded to alert the pedestrians. After the train has passed, the ultrasonic sensor will detect the absence of any obstacle and signal the servo motor to open the gate, allowing the pedestrians to cross the railway tracks. If an obstacle is detected by the ultrasonic sensor, the gate will remain closed, and the buzzer will continue to sound until the obstacle is removed. Overall, the proposed system will provide a reliable and efficient solution for ensuring the safety of railway crossings by automating the gate closing and

opening process, which is currently manually operated in many locations. The automatic railway gate system is a critical safety measure that helps to prevent accidents and fatalities at railway crossings. It is widely used in many countries around the world to improve railway safety and reduce the risk of accidents caused by human error. 4.4 Advantages: Increased safety: Automatic railway gate systems improve safety by preventing vehicles and pedestrians from crossing railway tracks when a train is approaching. Reduced accidents: By automatically closing the gates when a train is approaching, the chances of accidents between trains and vehicles or pedestrians are greatly reduced. Efficient: These systems are very efficient as they require no human intervention, thereby saving time and improving productivity.

Reduce the need for manual labour and maintenance costs. Environment-friendly: By reducing the chances of accidents, these systems also help reduce environmental damage caused by train accidents.

Applications:

Railway crossings: The primary application of the automatic railway gate system is at railway crossings where the system is installed to prevent accidents and collisions between trains and vehicles or pedestrians.

Level crossings: Level crossings are areas where the railway track intersects with the road or pathway, and automatic railway gate systems are used to close the gates when a train is approaching.

High-speed rail: Automatic railway gate systems are increasingly being used in high-speed rail applications to ensure the safety of passengers and workers. Remote areas: In remote areas, automatic railway gate systems are used to reduce the need for human intervention and improve the efficiency of the railway network.

IV RESULTS

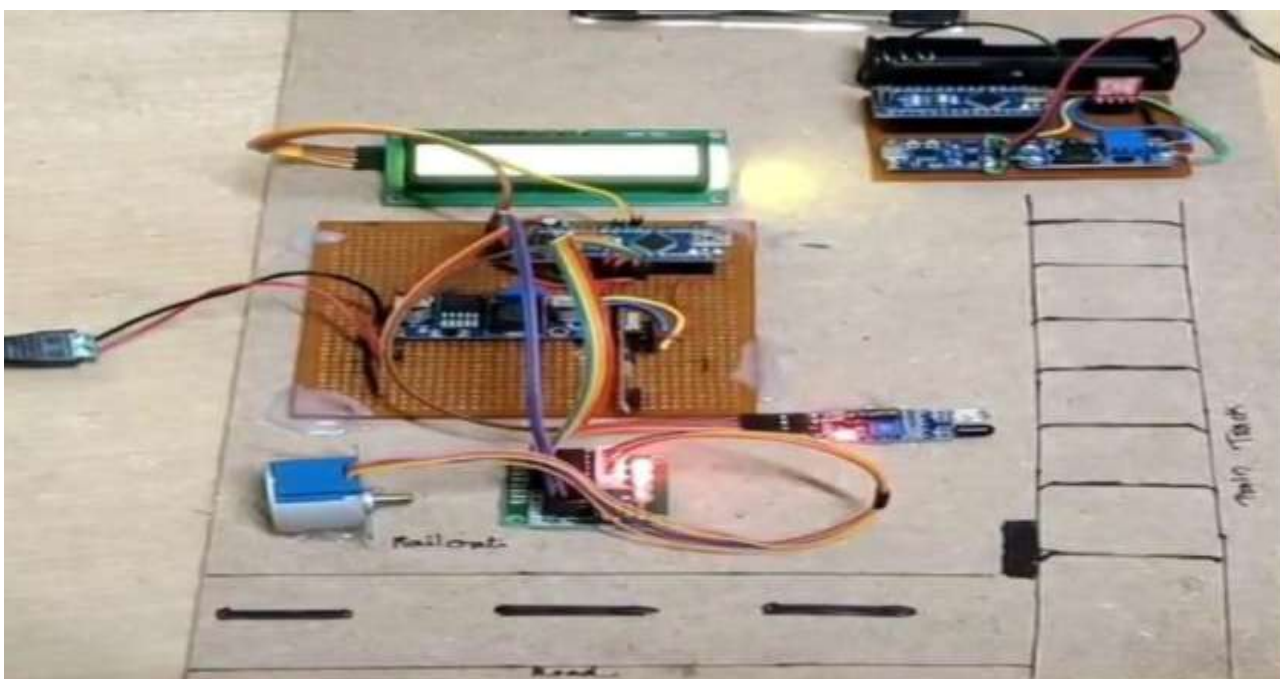

Before train is arrived near to railway gates it shows green led

- It means the ultrasonic sensor and IR sensor doesn't detects any object (Train)
- It represents safe that the vehicles can cross the railway gates
- The railway gates are remain open until IR & Ultrasonic sensor detects the train.
 - After train is has arrived near the railway gates the IR sensor & ultrasonic sensor detects the train and gives output as blue and red led Based on distance it sounds buzzer Then the gates remains closed until the train is departure.

V CONCLUSION:

The automatic railway gate system is a technology-based solution that helps in managing the railway crossings efficiently and safely. This system is designed to automate the process of closing and opening the railway gate at level crossings without any human intervention. The system works by using sensors and control units that detect the approach of a train and accordingly, the gate is closed or opened. The implementation of this system has several advantages such as reducing the risk of accidents at level crossings, increasing the efficiency of railway transportation, and improving the safety of passengers and vehicles. Additionally, it also helps in reducing the traffic congestion caused by the closure of gates during the passage of trains. In conclusion, the automatic railway gate system is a useful technology that has the potential to make railway transportation safer, efficient, and convenient. Its implementation can significantly reduce the risk of accidents and ensure a smooth flow of traffic on the road.

VI REFERENCES

1. N. A Zafar, S. A. Khan, K. Araki, "Towards the safety properties of moving block railway interlocking system," *Int. J. Innovative Comput., Info & Control*, vol 8(7), pp. 5677-5690, 2012.
2. J. Rushby, "Formal Methods and their role in the certification of critical systems," *Safety and Reliability of Software Based Systems*, pp. 1-42, 1997
3. P. Antoniou, J. Holub, C. S. Iliopoulos, B. Melichar, P. Peterlongo, "Finding common motifs with gaps using finite automata," *International Conference on Implementation and Application of Automata*, pp. 69-77, 2006.
4. K. Brouwer, W. Gellerich, E. Plödereder, "Myths and facts about the efficient implementation of finite automata and lexical analysis," *International Conference on Compiler Construction*, 1998.
5. N. Sabir, A. Ali, N.A. Zafar, "Linking finite automata and formal methods enhancing modeling power for complex systems," *International Conference on Computer Science and Information Technology, ICCSIT'08*, 2008.

10.48047/jocaaa.2024.33.08.57

6. V. Hartonas-Garmhausen, S. Campos, A. Cimatti, E. Clarke, F. Giunchiglia, "Verification of a safety-critical railway interlocking system with real-time constraints," In Fault-Tolerant Computing Digest of Papers. Twenty-Eighth Annual International Symposium, pp. 458- 463, 1998.