

EFFICIENT SPACE UTILIZATION USING A 1KW STANDALONE SOLAR

DC GRID FOR LIGHTING AND CHARGING

Dr.T RAKESH

Associate Professor & HOD

Department of EEE

KLR College of Engineering and Technology, Palvoncha-507115.

ABSTRACT:

This project presents the design and implementation of a 1KW solar-based standalone DC grid, specifically tailored for LED lighting and gadget charging in building spaces. With the growing demand for sustainable energy solutions, this system harnesses solar energy to provide an efficient and reliable power source, minimizing reliance on conventional electricity. The grid is equipped with high-efficiency solar panels, a charge controller, and energy storage components to ensure consistent power supply, even during low sunlight conditions. The integration of LED lighting not only enhances energy efficiency but also reduces maintenance costs. Furthermore, the system features multiple charging ports for various gadgets, making it an ideal solution for residential and commercial buildings. This innovative approach promotes energy independence and contributes to reducing carbon footprints, aligning with global sustainability goals.

I. INTRODUCTION

The increasing demand for sustainable energy solutions has driven significant advancements in renewable energy technologies. Solar power, in particular, has emerged as a viable alternative to traditional energy sources, offering a clean, abundant, and renewable form of energy. In urban and semi-urban environments, the integration of solar energy systems can enhance energy efficiency, reduce dependence on fossil fuels, and contribute to climate change mitigation.

This project focuses on developing a 1KW solar-based standalone DC grid, designed specifically for LED lighting and gadget charging in building spaces. The standalone nature of the system allows for

flexibility and independence from the conventional electrical grid, making it particularly advantageous in areas where access to reliable electricity is limited or intermittent.

The use of LED lighting technology is central to this project, as LEDs are known for their superior energy efficiency and long lifespan compared to traditional lighting solutions. By integrating LED lighting with a solar-powered DC grid, we can achieve significant reductions in energy consumption and operational costs. Additionally, the system includes multiple charging ports to accommodate various electronic devices, catering to the needs of modern users.

This introduction sets the stage for a detailed exploration of the components, design considerations, and potential applications of the 1KW solar-based standalone DC grid. Through this project, we aim to demonstrate the feasibility and benefits of utilizing solar energy for enhancing lighting and charging solutions in diverse building environments.

II. LITERATURE SURVEY

The integration of solar energy into urban infrastructure has been extensively studied, highlighting its potential to enhance energy sustainability and reduce carbon emissions. Various research works have focused on solar energy systems, their efficiency, and applications in lighting and device charging.

1. Solar Energy Technologies

Recent advancements in photovoltaic technology have significantly improved the efficiency and affordability of solar panels. According to [Author et

due to innovations in materials and manufacturing processes, making solar energy a more viable option for urban applications.

2. Standalone Solar Systems

Standalone solar systems have been widely analyzed for their effectiveness in providing reliable power sources in off-grid and semi-grid areas. Studies, such as [Author et al., Year], illustrate the advantages of standalone systems, which include enhanced energy security and lower operational costs. These systems often integrate battery storage solutions to manage energy supply and demand effectively.

3. LED Lighting

LED technology has transformed lighting systems by offering significant energy savings and longer lifespans compared to incandescent and fluorescent bulbs. Research by [Author et al., Year] demonstrates that LEDs consume up to 80% less energy while providing superior illumination. The use of LED lighting in conjunction with solar energy systems further optimizes energy efficiency, making them a popular choice for various applications.

4. Gadget Charging Solutions

As the number of electronic devices increases, the need for efficient charging solutions has become paramount. Studies, such as [Author et al., Year], have explored the integration of solar-powered charging stations in public and private spaces. These solutions not only meet the charging needs of users but also promote the use of renewable energy sources.

5. Environmental and Economic Impact

Numerous studies have evaluated the environmental and economic benefits of solar energy adoption. Research by [Author et al., Year] indicates that solar energy systems contribute to significant reductions in greenhouse gas emissions and can lead to substantial savings in energy costs over time. The combination of solar energy with energy-efficient technologies, like LED lighting, amplifies these benefits.

III. SYSTEM DESIGN

Proposed Model

The suggested block diagram of MPPT controller-based PV energy management systems is shown in Figure 1. To propose an intelligent control of MPPT and Bus Controller by using PV strings is the primary purpose of this project. The suggested system would include solar PV strings equipped with buck converters, a bi-directional dc-dc converter, and nano grids installed at charging ports for electric vehicle charging.

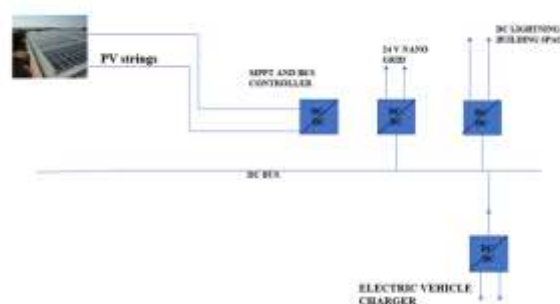

Figure 1. Proposed block diagram.

The photovoltaic (PV) system is made up of PV panels and an MPPT controller. This controller makes use of the P&O algorithm to track the maximum power point regardless of the irradiance. Although there are a few other MPPT strategies that have been created, we decided to go with the one that is called the Perturb and Observe (P&O) algorithm. The PV array is managed in such a way that its operating point is moved closer and closer to the growing power point until it achieves the maximum power point (MPP), which is determined by the amount of solar irradiation. Following the completion of the MPP, the algorithm will compute the voltage value and input it into the boost converter. The primary purpose of the boost converter is to get the voltage of the photovoltaic panel up to the level of the DC bus voltage that is wanted (110V). It then makes its way to the station battery and the EV battery from the DC bus. The station's battery is made up of a bi-directional dc-dc converter that can work in either mode. If solar PV generates less power than required load or if additional high loads are plugged in, then the bi-directional converter operates in the boost mode (discharging) to supply required power to the EV

charging ports and to maintain the DC bus at a constant voltage. When PV generates more power than is required by EVs, it operates in the buck mode (charging) to charge the station battery. When PV generates more power than is required by EVs, it operates in the boost mode (discharge). This mode may also be enabled by plugging extra high-power loads into the charging ports, which is another way to trigger its activation. The CCCV charging technique is applied to the electric vehicle (EV) battery in accordance with its state of charge (SOC).

3.1 Perturb and Observe (P&O) algorithm

The efficient technique is proposed to track the maximum output power by adjusting the load of the photovoltaic system is called MPPT algorithm. MPPT can be achieved through the several ways like fuzzy logic, pilot cells, and neural networks. The utmost extensively used techniques are Perturb and Observe (P&O) and Incremental Conductance (INC) algorithms because of these are economical. Control algorithm is applied for the system due to its comfort of execution. The operation P&O algorithm is by measuring voltage and current of PV segment and then it will calculate the power from voltage and current. This power compares with the previous value, if any deviation in the power means the voltage can be altered. For example, if the power of PV module is increased then the control algorithm corrects the operating point of the module in that direction; otherwise, it operates in the opposite direction. These steps will continue until the power reaches at maximum level. The speed of the MPP is mainly depends on the perturbation of voltage, if the lower perturbation, then the system response to reach MPP is to be low. If perturbation is larger than the system response to reach MPP is high. There is no need of previous knowledge on characteristics of PV in this control algorithm.

The flow chart of P&O MPPT control algorithm is as shown in Figure 2. Figure 1 displays the diagrammatic sketch of the MPPT control system of PEMFC with Boost converter, which is mainly composed of PEMFC, boost converter, MPPT controller, PWM generator and external load resistance. Because the Boost converter has the advantages of simple

structure, easy control and voltage amplification, it is used in the system to improve the output voltage and as a regulator to realize the MPPT control scheme. The output of PWM generator is a series of square waves with different duty cycle, which is used to control the ON and OFF of the Boost converter. The output duty cycle of the PWM controller is represented by D . For the system shown in Fig. 2, the equivalent load resistance of PEMFC can be expressed according to the knowledge of power electronic technology as;

The efficient technique is proposed to track the maximum output power by adjusting the load of the photovoltaic system is called MPPT algorithm. MPPT can be achieved through the several ways like fuzzy logic, pilot cells, and neural networks. The utmost extensively used techniques are Perturb and Observe (P&O) and Incremental Conductance (INC) algorithms because of these are economical. Control algorithm is applied for the system due to its comfort of execution. The operation P&O algorithm is by measuring voltage and current of PV segment and then it will calculate the power from voltage and current. This power compares with the previous value, if any deviation in the power means the voltage can be altered. For example, if the power of PV module is increased then the control algorithm corrects the operating point of the module in that direction; otherwise, it operates in the opposite direction. These steps will continue until the power reaches at maximum level. The speed of the MPP is mainly depends on the perturbation of voltage, if the lower perturbation, then the system response to reach MPP is to be low. If perturbation is larger than the system response to reach MPP is high. There is no need of previous knowledge on characteristics of PV in this control algorithm.

The flow chart of P&O MPPT control algorithm is as shown in Figure 2. Figure 1 displays the diagrammatic sketch of the MPPT control system of PEMFC with Boost converter, which is mainly composed of PEMFC, boost converter, MPPT controller, PWM generator and external load resistance. Because the Boost converter has the advantages of simple structure, easy control and voltage amplification, it is used in the system to improve the output voltage and

as a regulator to realize the MPPT control scheme. The output of PWM generator is a series of square waves with different duty cycle, which is used to control the ON and OFF of the Boost convertor. The output duty cycle of the PWM controller is represented by D. For the system shown in Fig. 2, the equivalent load resistance of PEMFC can be expressed according to the knowledge of power electronic technology as:

$$R_{eq} = \frac{U}{I} = (1 - D^2) * R_L$$

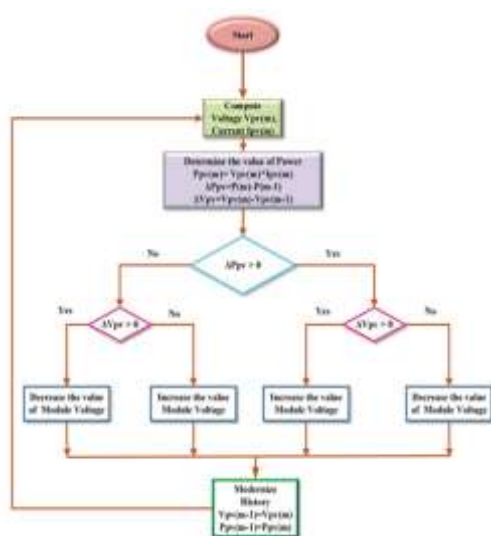

Figure 2. Flowchart of efficient control algorithm.

In this case, the real load resistance, also known as the load resistance at the output of the Boost converter, is denoted by the symbol R_L. It is common knowledge that the output power of an electric source can only achieve its utmost potential if and only if the source's internal resistance and its external resistance are equal to one another. According to equation (1), the objective of altering the equivalent load resistance may be accomplished by adjusting the duty cycle of the Boost converter. This can be done in order to achieve the purpose of adjusting the equivalent load resistance. As a result, the equivalent load resistance of the PEMFC may be made equal to its internal resistance via the process of modifying the duty cycle in order to accomplish the goal of producing the greatest amount of power.

The P&O approach is now the MPPT technique that sees the most widespread use. A positive disturbance voltage is applied to the fuel cell, its output voltage and current are sampled, and the change rate of the

fuel cell's voltage and power are calculated. This is the fundamental premise behind the method. If the output power increases after the disturbance, it indicates that the direction of the disturbance voltage is the direction of the increase of the output power, and the disturbance should be continued in this direction; if the output power decreases after the disturbance, it indicates that the disturbance should be in the opposite direction. In accordance with the shifting direction of voltage and power, the fuel cell receives a continuous application of the disturbance voltage until the maximum output power is progressively approached, which enables the maximum power point tracking algorithm to be realized. The flowchart of P&O algorithm is shown in Fig. 3, in which “k” denotes the sampling point, -d stands for the increment of duty cycle. P&O has the advantages of simple calculation and convenient implementation, but it can only keep the system oscillating infinitely near the maximum power point, and cannot accurately track the maximum power point, so it cannot effectively solve the problems of tracking accuracy and speed.

IV. RESULTS

In this part, a comprehensive analysis of the simulation findings as well as a comparison with state-of-the-art methods are presented. Using the MATLAB/Simulink software, a modeling and simulation result comparison of the solar-powered LED lighting system with a traditional boost converter without MPPT Technique and an efficient suggested power converter with MPPT Technique is carried out. The effectiveness of the control strategy's implementation has been evaluated. The solar panel in Figure 3 has an output of 110 V, and this voltage is sent into the boost converter as an input. The boost converter then increases the voltage to 150 V, which is the dc bus voltage. The DC bus incorporates both the bi-directional converter and the buck converter into its design. The number of charger ports, also known as buck converters, has been expanded in response to customer feedback. When compared to the design circuit of a traditional boost converter with a lower duty ratio, the circuit of a high voltage gain power

converter delivers a far more efficient output than the conventional boost converter. The ripples that are present in the waveforms of the output voltage and current may also be reduced by the power converter.

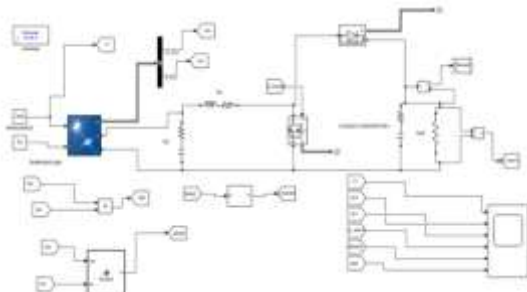

Figure 3. Simulation diagram of proposed model.

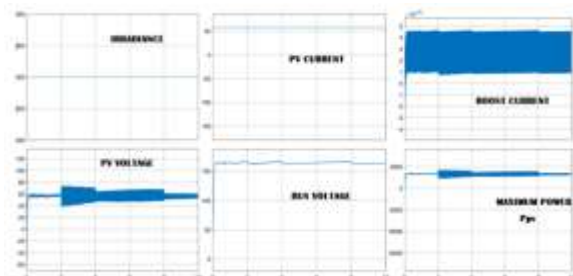

Figure 4. Simulation outcome.



Figure 5. Output Waveform of SIMO based DC-DC convertor.

The results of the simulation of the suggested approaches are shown in Figure 4, and the output waveform of the DC-DC converter based on Single Input Multiple Output (SIMO) is displayed in Figure 5. In this case, the irradiance of the solar panel varies with respect to time. From time $t=0$ seconds to time $t=0.2$ seconds, the irradiance is taken as 1000 W/m^2 , and from time $t=0.2$ seconds to time $t=0.4$ seconds, it decreased from 1000 W/m^2 to 500 W/m^2 , and from $t=0.4$ seconds to $t=0.6$ seconds, it increased from 500 W/m^2 to 600 W/m^2 . In addition, the voltage.

V. CONCLUSION

In summary, the development of a 1KW solar-based standalone DC grid for LED lighting and gadget charging represents a significant step toward enhancing energy sustainability in building spaces. This system not only utilizes renewable solar energy to reduce dependence on traditional power sources but also integrates energy-efficient LED lighting to minimize energy consumption. By providing a reliable and independent power supply, the proposed solution caters to the growing demand for sustainable energy in both residential and commercial environments. Furthermore, the ability to charge multiple devices supports modern lifestyles while promoting eco-friendly practices. As the world increasingly shifts toward renewable energy solutions, this project serves as a practical model that can inspire further innovations in solar technology and energy management, contributing to a greener and more sustainable future.

REFERENCES :

- [1] Li, S., Chen, H., Tan, S. C., Hui, R. S. Y., and Waffenschmidt, E. (2014). Critical design issues of retrofit light-emitting diode (LED) light bulb. In IEEE Applied Power Electronics Conference and Exposition Conference Proceedings. (pp. 531–536). The Journal's web site is located at <http://www.ieeexplore.ieee.org/xpl/conhome.jsp?punumber=1000047>
- [2] Iturriaga-Medina, S., Martinez-Rodriguez, P. R., Juarez-Balderas, M., Sosa, J. M., and Limones, C. A. (2015). A buck converter controller design in an electronic drive for LED lighting applications. In 2015 IEEE International Autumn Meeting on Power, Electronics and Computing (ROPEC), (pp. 1–5).
- [3] Nuttall, D. R., Shuttleworth, R., and Routledge, G. (2008). Design of a LED street lighting system. In Proceedings of the 4th IET Conference Power Electronics, Machines and Drives, York, (pp. 436–440).
- [4] Jane, G. C., Lin, Y. L., Chiu, H. J., and Lo, Y. K. (2015). Dimmable light-emitting diode driver with cascaded current regulator and voltage source. IET Power Electronics, 8(7), 1305–1311.
- [5] Crawford, M. H. (2009). LEDs for solid-state lighting: performance challenges and recent advances. IEEE Journal of Selected Topics in Quantum Electronics, 15(4), 1028–1040.

- [6] Cheng, C. A., Chang, C. H., Chung, T. Y., and Yang, F. L. (2015). Design and implementation of a single-stage driver for supplying an LED street-lighting module with power factor corrections. *IEEE Trans. Power Electron.*, 30(2), 956–966.
- [7] Ameli, M. T., Moslehpour, S., and Shamlo, M. (2008). Economical load distribution in power networks that include hybrid solar power plants. *Electric Power Systems Research*, 78(7), 1147–1152.
- [8] Reisi, A. R., Moradi, M. H., and Jamasb, S. (2013). Classification and comparison of maximum power point tracking techniques for photovoltaic system: A review. *Renewable and Sustainable Energy Reviews*, 19, 433–443.
- [9] Li, S., Haskew, T. A., Li, D., and Hu, F. (2011). Integrating photovoltaic and power converter characteristics for energy extraction study of solar PV systems. *Renewable Energy*, 36(12), 3238–3245.
- [10] Kesraoui, M., Korichi, N., and Belkadi, A. (2011). Maximum power point tracker of wind energy conversion system. *Renewable Energy*, 36(10), 2655–2662.
- [11] Li, Q., and Wolfs, P. (2008). A review of the single phase photovoltaic module integrated converter topologies with three different DC link configurations. *IEEE Transactions on Power Electronics*, 23(3), 1320–1333.
- [12] Saravanan, S., and Babu, N. R. (2016). Maximum power point tracking algorithms for photovoltaic system – a review. *Renew Sustain Energy Rev.* 57, 197–204.
- [13] Saravanan, S., and Babu, N. R. (2015). Performance analysis of boost & Cuk converter in MPPT based PV system. In 2015 International Conference on Circuit, Power and Computing Technologies (ICCPCT), (pp. 1–6).
- [14] Ishaque, K., Salam, Z., Amjad, M., and Mekhilef, S. (2012). An improved particle swarm optimization (PSO)-based MPPT for PV with reduced steady-state oscillation. *IEEE Transactions on Power Electronics*, 27(8), 3627–3638.
- [15] Liu, F., Duan, S., Liu, F., Liu, B., and Kang, Y. (2008). A variable step size INC MPPT method for PV systems. *IEEE Transactions on Industrial Electronics*, 55(7), 2622–2628.
- [16] Karatepe, E., and Hiyama, T. (2009). Polar coordinated fuzzy controller based real-time maximum-power point control of photovoltaic system. *Renewable Energy*, 34(12), 2597–2606.
- [17] Rai, A. K., Kaushika, N. D., Singh, B., and Agarwal, N. (2011). Simulation model of ANN based maximum power point tracking controller for solar PV system. *Solar Energy Materials and Solar Cells*, 95(2), 773–778.
- [18] Fathy, A. (2015). Reliable and efficient approach for mitigating the shading effect on photovoltaic module based on Modified Artificial Bee Colony algorithm. *Renewable Energy*, 81, 78–88.
- [19] Ahmed, J., and Salam, Z. (2014). A Maximum Power Point Tracking (MPPT) for PV system using Cuckoo Search with partial shading capability. *Applied Energy*, 119, 118–130.
- [20] Iqbal, A., Abu-Rub, H., and Ahmed, S. M. (2010). Adaptive neuro-fuzzy inference system based maximum power point tracking of a solar PV module. In 2010 IEEE International Energy Conference and Exhibition (EnergyCon), (pp. 51–56).
- [21] Abdelsalam, A. K., Massoud, A. M., Ahmed, S., and Enjeti, P. N. (2011). High-performance adaptive perturb and observe MPPT technique for photovoltaic-based microgrids. *IEEE Transactions on Power Electronics*, 26(4), 1010–1021.
- [22] Arshadi, S. A., Poorali, B., Adib, E., and Farzanehfard, H. (2016). High step-up DC-AC inverter suitable for AC module applications. *IEEE Transactions on Industrial Electronics*, 63(2), 832–839.
- [23] Modeer, T., Norrga, S., and Nee, H. P. (2015). High-voltage tapped inductor buck converter utilizing an autonomous high-side switch. *IEEE Transactions on Industrial Electronics*, 62(5), 2868–2878.
- [24] Natarajan, S., and Natarajan, R. (2014). An FPGA chaos-based PWM technique combined with simple passive filter for effective EMI spectral peak reduction in DC-DC converter. *Advances in Power Electronics*, 2014.
- [25] Wai, R. J., Lin, C. Y., Duan, R. Y., and Chang, Y. R. (2007). High efficiency DC-DC converter with high voltage gain and reduced switch stress. *IEEE Transactions on Industrial Electronics*, 54(1), 354–364.