

MPPT Algorithm based IBC and IBC Lift C Solar Photo Voltaic System

A S Suresh¹, R Zahira²

^{1,2}Department of Electrical and Electronics Engineering, B.S.A Crescent Institute of Science and Technology, Chennai, India

¹ssuresh@crescent.education, ²zahira@crescent.education

ABSTRACT

The output voltage accessibility from the sustainable source like photo voltaic (PV), power modules and battery banks are too low in practical utility. Therefore, the accessible voltage must be ventured up impressively before interfacing with the load. The performance of the PV panel is dependent on energy from the sun and temperature of the cell. Subsequently, the most extreme output power of the PV module fluctuates with the progressions in solar irradiation and temperature of the cell. The overall efficiency of solar PV panel improves by tracking the maximum power with help of power electronics devices. The maximum power point tracking achieved by the Perturb & Observe (P&O) controller for comparative analysis of the boost converter(BC), interleaved boost converter(IBC) and interleaved boost with Lifting capacitor (IBC Lift C). In this paper IBC is proposed. Two interleaved stage simulated and results are compared and analyzed in this proposed method. All methods are simulated in Matlab/Simulink software.

Keywords

Boost Converter; Interleaved Boost Converter; Interleaved Boost Converter Lift Capacitor; Perturb & Observe; Maximum Power Point Tracking;

Article Received: 10 August 2020, Revised: 25 October 2020, Accepted: 18 November 2020

Introduction

In present day’s electric power is generated with various sources such as PV, wind, fuel cell, tidal, etc. Among which, the solar PV electrical power generation has played a vital role in the past two decades. The maximum power point tracking (MPPT) is used to trace the maximum voltage and current automatically in the solar PV array. Different MPPT control techniques used to capture maximum energy to the solar PV modules (1-7). H. Malek et al (8) discussed the faster MPPT applied to the solar panel. The efficiency of Solar PV is low because its output power depending upon on irradiation & cell temperature, which increase the output side voltage and power with the help of DC-DC BC. The boost output voltage to be increased by the various duty ratios modeled with DC-DC converter (9-11). Normally BC is used to improve the high voltage gain also increasing the efficiency level. If the DC-DC converter switching frequency is limited, the output voltage is diminished. In (12) dealing with comparison of a standard BC to the quadratic BC. In (13-19) completely discussed to be modeled the ripple free boost converter topologies. Nowadays modified BC required because of better efficiency to increase the output voltage and obtain the smooth waveform. The modified BC and phase shifted pwm techniques used is called the IBC (20). A proposed new topology to be modeled IBC. The various stages of IBC are discussed in (21-29). In spite of this authors discussed the model for the IBC. This paper additionally proposes one more method to simulate and compare the result to the IBC. The proposed new method is called IBC Lift C. The solar PV MPPT using P&O for the BC, IBC and IBC Lift C are simulated in Matlab/Simulink, at difference irradiance and constant cell temperature. The above three methods are simulated and their performance analyzed individually. Also comparative analysis of IBC and IBC Lift C is discussed in detailed in this paper.

Modelling Of Solar PV Cell

The PV modules are arranged in series and shunt for obtaining the appropriate level of voltage and current values. The numerical displays are necessary to determine the generating voltage and power under various loading conditions. Fig.1 shows the PV equivalent circuit. Equation (1) is determines the output of PV current.

$$I = I_{PC} - I_{sat} (q^{V_{pv} + I \times R_{se}} / nKT - 1) - (V_{pv} - I \times R_{se}) / R_p \quad (1)$$

Where,

I =Output Current PV Cell in A.

I_{PC} = Photocurrent in A.

I_{sat} = Diode Saturation Current in A.

q = Charge of an electrons (1.6x10⁻¹⁹) in C.

V_{pv} = Output Voltage PV Cell in V.

R_{se} = Series resistance in ohm.

K= Boltman’s Constant in J/K.

T = Temperature in K.

n=Ideality factor (1~2).

R_p = Parallel resistance in Ω.

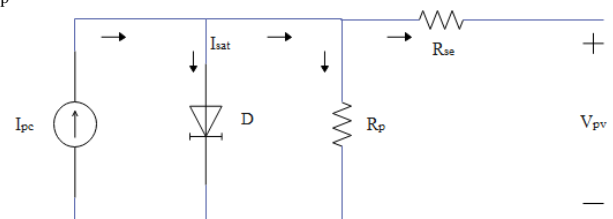

Figure 1. PV Cell Equivalent Circuit

The photocurrent relies upon sunlight-based irradiance and cell temperature which is indicated by the accompanying condition from reference (1) and use (2) to get the photo current values.

$$I_{PC} = I_{sc} + k_i (T_{cell} - T_{ref}) \times \frac{H_{irr}}{1000} \quad (2)$$

I_{sc} = Short Circuit Current in A.
 k_i = Temperature Coefficient.
 T_{cell} = Cell Temperature in K.
 T_{ref} = Reference Temperature of a cell in K.
 H_{irr} = Solar Irradiation in W/m^2 .

Electrical Parameter For Solar PV Module

Solar PV module simulated with help of Matlab software, the electrical parameter listed in the Table 1. Also, in Fig.2 and Fig.3 shows the I-V and P-V characteristics of solar PV module.

Table 1 Type Styles Solar Pv Module Electrical Parameter

Module Parameters	1Soltech 1STH-215-P
P_m (Peak Power)	213.15 W
V_{oc} (Open Circuit Voltage)	36.3 V
V_{mp} (Voltage at MPPT)	29 V
N_{cell} (Cell per module)	60
I_{sc} (Short circuit current)	7.84 A
I_{mp} (Current at MPPT)	7.35 A

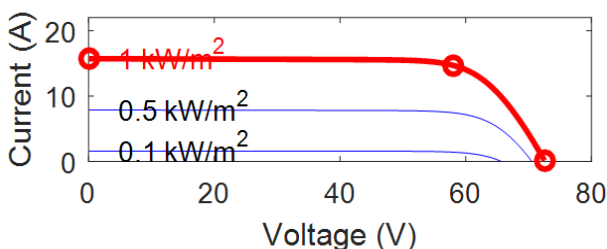

Figure 2. Different Irradiation Level PV module I-V characteristics(Array type: 1Soltech I STH-215-P)

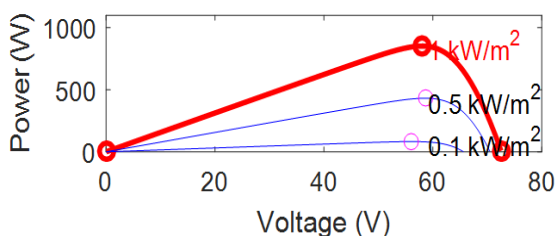

Figure 3. Different Irradiation Level PV module P-V characteristics (Array type:1Soltech I STH-215-P)

Design Of DC-DC Boost Converter

Fig.4 shows the MPPT based BC which comprises of a diode, inductance (L) and capacitance (C). The BC is utilized for boosting the level of output voltage. The DC sources such as DC generators, batteries, etc have the ability to take care of BC. It is observed that the duty cycle also increases to obtain the MPPT in the PV module of the BC, with expansion in solar radiance and temperature of the cell. Equation 3 gives the output voltage of BC.

$$V_{out} = \frac{V_{in}}{(1-d)} \quad (3)$$

Where

V_{in} = Input Voltage in V

V_{out} = Output Voltage in V

d = Duty Cycle.

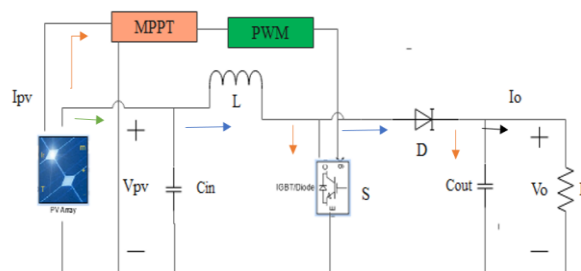

Figure 4. MPPT based BC

Design Of Interleaved Boost Converter (IBC)

Fig.5 shows the circuit diagram of IBC in which the ripple content in the input current and output voltage are reduced in each phase. From the semiconductor switches, the current stress and voltage stress decrease, in that the current splits in to the parallel paths. Equations (4) and (5) are used to decrease the ripple in I_{in} of IBC.

$$\frac{\Delta I_{in}}{I_{in}} = \frac{(1-d)^2 * d * T_s}{\frac{L_T}{R}} \quad (4)$$

$$T_s = \frac{L_T}{R} \quad (5)$$

Where,

T_s = Time Constant in second.

L_T = Equivalent inductance in H.

R =Load resistance in ohm.

I_{in} = Input current in A.

Based on the values of the L and C, time constant (T_s) and ripple current are reduced. Also, the voltage ripple reduced keeping the switching period is less than the time constant. Equations (6) and (7) are used to determine the voltage ripple and time constant of IBC

$$\frac{\Delta V_o}{V_o} = \frac{d * T_s}{R * C_{out}} \quad (6)$$

$$T_s = R * C_{out} \quad (7)$$

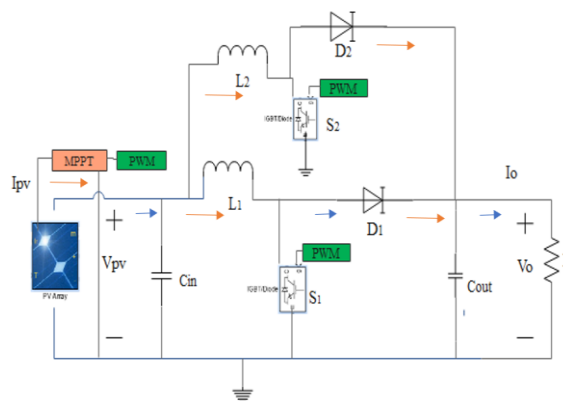

Figure 5. MPPT based IBC

Design Of Interleaved Boost Converter Lift Capacitor (IBC Lift C)

Fig.6 shows the simple two-phase IBC topology consisting of a capacitor C_m . IBC Lift C having the two inductors (L_1 and L_2), two diodes (D_1 and D_2) and two switches (S_1 and S_2) are used. Total ripple input current decreases in phase shift switching methods. The ripple content reduces the input current and output voltage is same in the IBC topology.

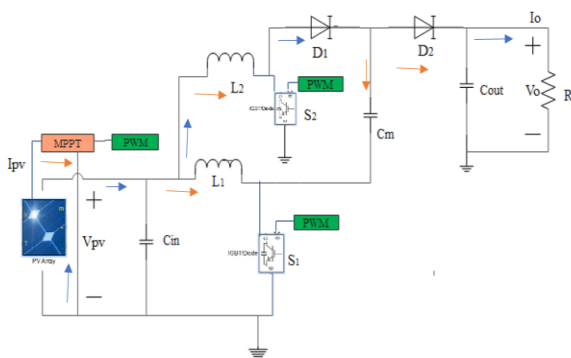

Figure 6. MPPT based IBC Lift C

P & O- MPPT

The P&O approach utilizes voltage and current sensors to measure the solar PV power output. The calculation of the P&O MPPT procedure is shown in Fig.7. By modifying the duty cycle (d) after a fixed measure of time, the P&O calculation tests predicted input power. When the input voltage and power levels are higher than the previous calculated values, then the duty cycle reduces to achieve closer maximum power.

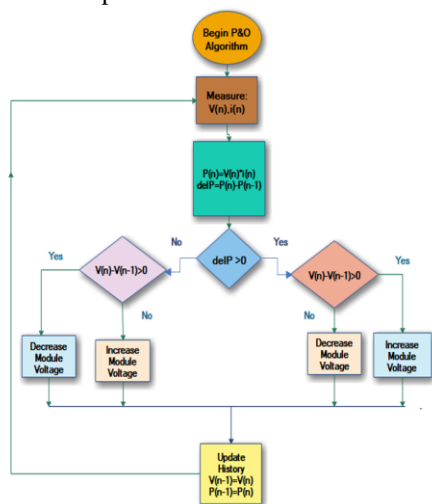

Figure 7. Flowchart of the P&O Algorithm

A.Simulations for BC, IBC and IBC Lift C

The standard DC-DC BC, IBC and IBC Lift C simulation is carried out using MATLAB/Simulink software. Assuming, the solar irradiation 800 W/m^2 and temperature of the cell is 250 C . This section presents the simulation of the above three methods.

The simulation of BC is shown in Fig.8. Output voltage and output power of BC increases based on the irradiation value increased here to fix the temperature 250 C is constant. Thus the output power gradually increased based on the time, from the graph to be noticed that the maximum power attained at the time depends upon 8 seconds. The output power reached stable condition after 8 seconds only. The transient's behavior of the output response is more.

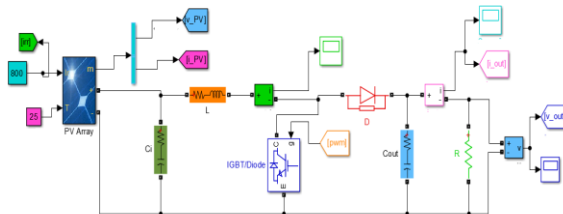

Figure 8. Simulation of BC

From the Fig.9 and Fig.10 shows that the input and output voltages for the BC. The ripple output voltage 162.5 V settled at 8 seconds.

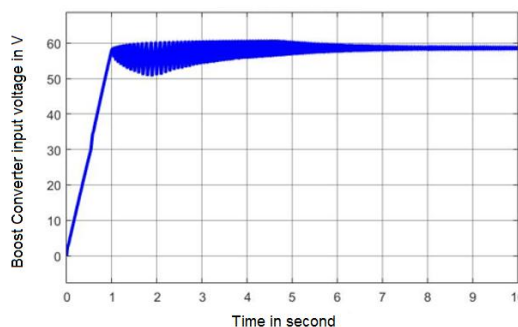

Figure 9. Waveform of BC input voltage

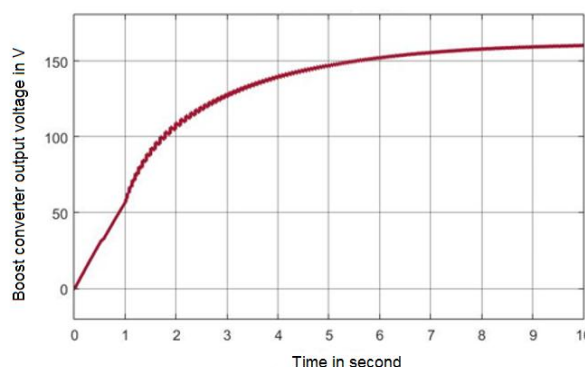

Figure 10. Waveform of BC output voltage

From the Fig.11 and Fig.12 shows that the ripple content input and output current waveform of the BC. The output current 4.15 A settled at 8 seconds shown in Fig.12.

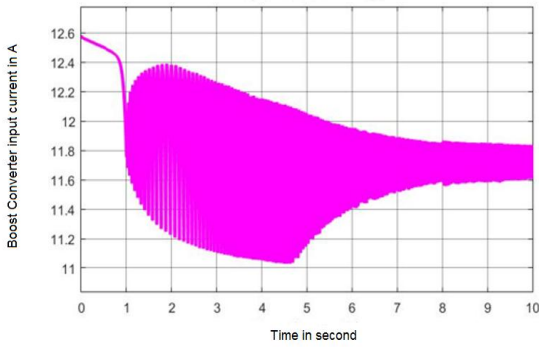

Figure 11. Ripple BC input current waveform

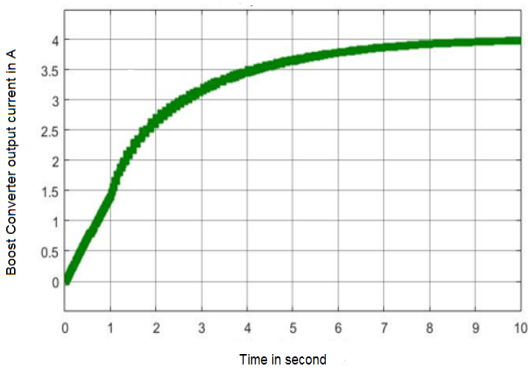

Figure 12. Ripple BC output current waveform

The input, output power of BC as shown in Fig.13 and Fig.14. The output steady state power 620.5 W settles at 9.5 seconds, also output power having more transient's behavior.

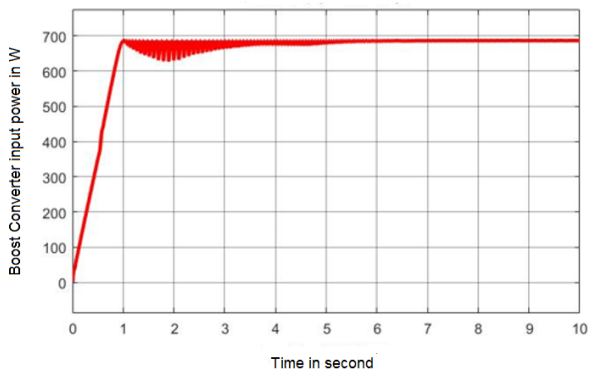

Figure 13. BC input power waveform

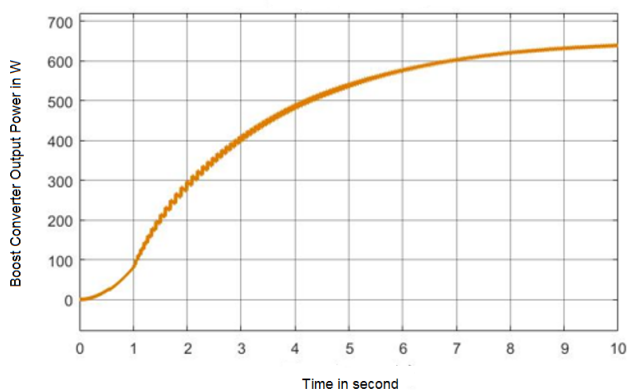

Figure 14. BC output power waveform

B. Simulation of IBC

IBC simulation as shown in Fig.15. To fix the exact values of the L and C to attain the proper output voltage and output power respectively. From the Fig.16 and Fig.17 shows the IBC input and output voltages. IBC output voltage value 477.9 V settled at 1.35 seconds. The input and output current waveform of IBC is depicted in the Fig.18 and Fig.19. IBC output current 1.04 A settled at 1.35 seconds. IBC output voltage and power values are shown in the table II and III. The output voltage, current and powers are very smooth. Fig.20 shows the input power IBC, in which IBC MPPT attained quickly compared with BC this shows in Fig.21 very clearly. The output steady state power 510.1 W settled at 1.35 seconds.

In this proposed method transient behavior of the output response minimum. When the steady state converter method is applied the output voltage of IBC is very smooth and higher values. To run the simulation up to 10 seconds, the irradiation level 800 W/m² also maintain the cell temperature 250 C is constant.

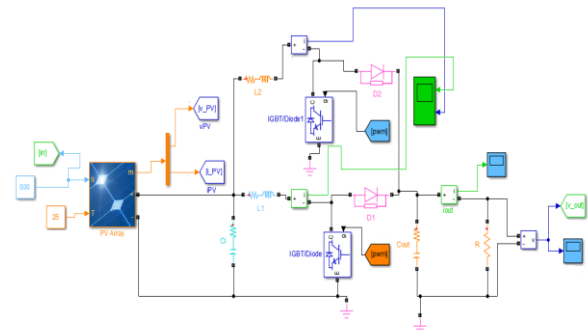

Figure 15. Simulation of IBC

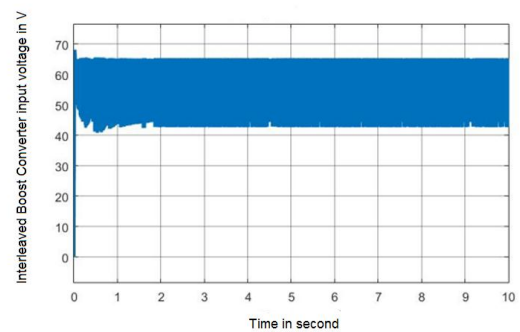

Figure 16. Waveform of IBC input voltage

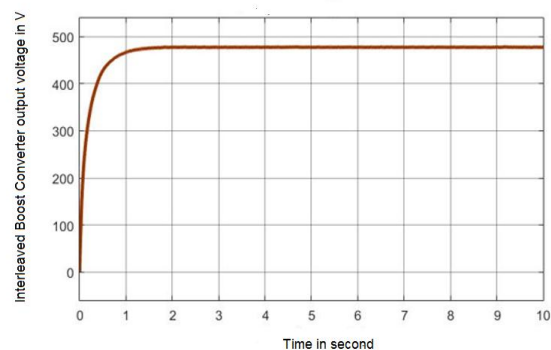

Figure 17. Waveform of IBC output voltage

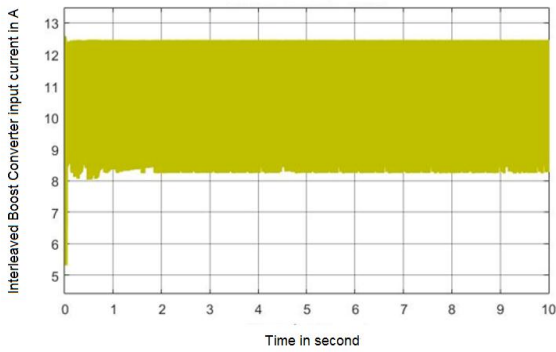

Figure 18. Waveform of IBC input current

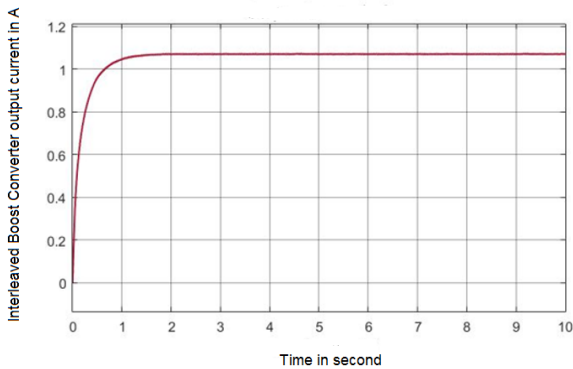

Figure 19. Waveform of IBC output current

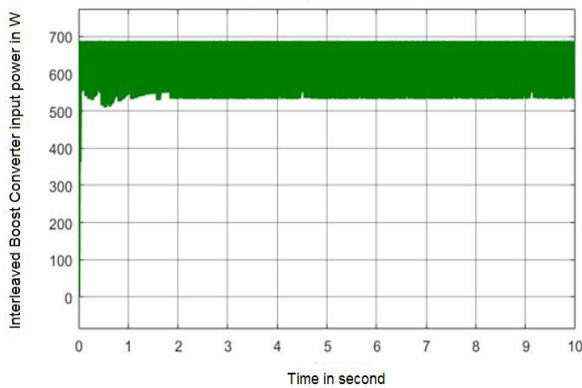

Figure 20. IBC input power waveform

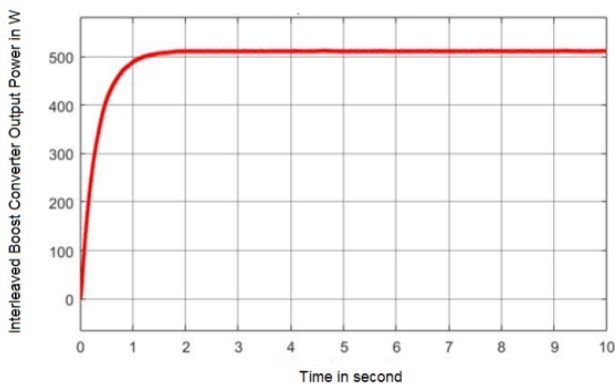

Figure 21. IBC output power waveform

C. Simulation of IBC Lift C

Fig.22 shows simulation result of the IBC Lift C converter. From the Fig.23 and Fig.24 shows the IBC Lift C input and output voltages. IBC Lift C output voltage value 470.6 V settled at 1.87 seconds. The input and output current waveform of IBC is depicted in the Fig.25 and Fig.26. IBC output current 1.032 A settled at 1.87 seconds. The output power is almost same as the IBC method. IBC Lift C method output response behaviour transient's minimum compare with BC. The MPPT tracking quickly attained is compared with BC. From the Fig.27 and Fig.28 shows the IBC Lift C input and output powers. IBC Lift C output steady state power 501.5 V settled at 1.87 seconds.

Overall voltage and power comparison carried out different irradiation level solar PV module at constant temperature 250 C, listed in the Table 2. From the comparison, the maximum power output attained in the method of IBC. From the Fig.29 and Fig.30 shown the overall output voltage and power compares in different irradiation value with constant temperature.

The IBC MPPT is faster than the two methods. Power Transfer efficiency is decreased in the IBC and IBC Lift C compare with BC, because a greater number of elements involved that so power loss increasing, it affects the output power automatically. This paper analyses MPPT quickly attained the method IBC.

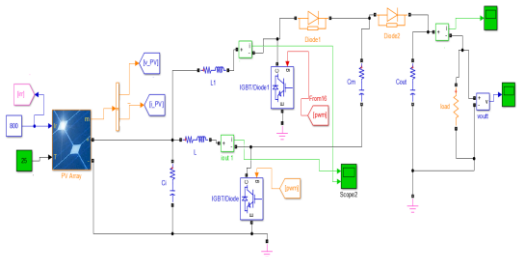

Figure 22. Simulation of IBC Lift C

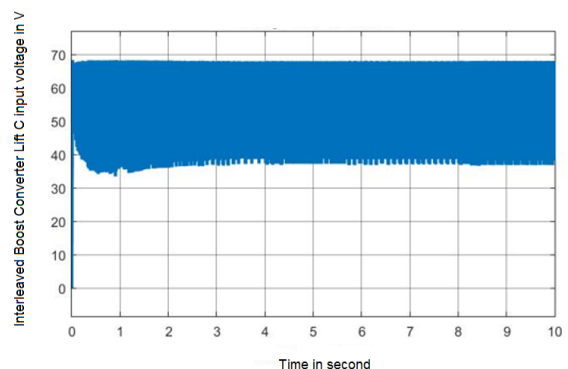

Figure 23. IBC Lift C input voltage waveform

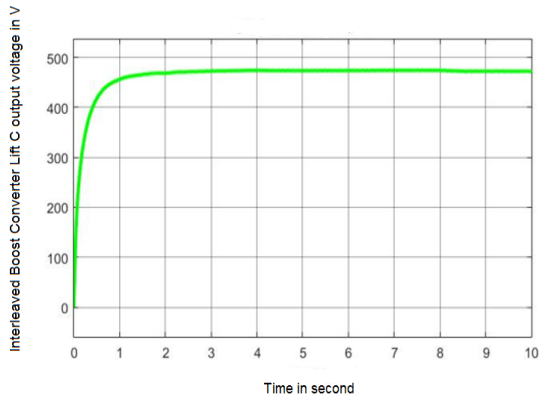

Figure 24. IBC Lift C input voltage waveform

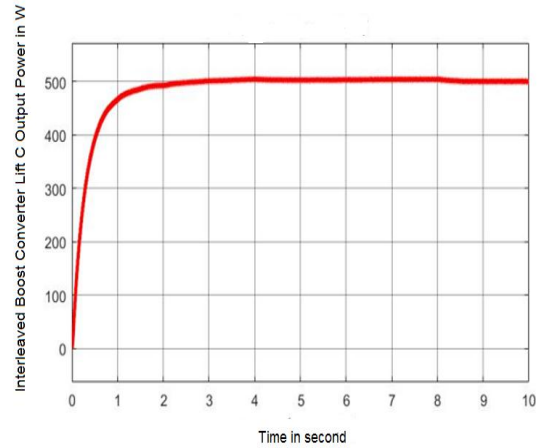

Figure 28. IBC Lift C output power waveform

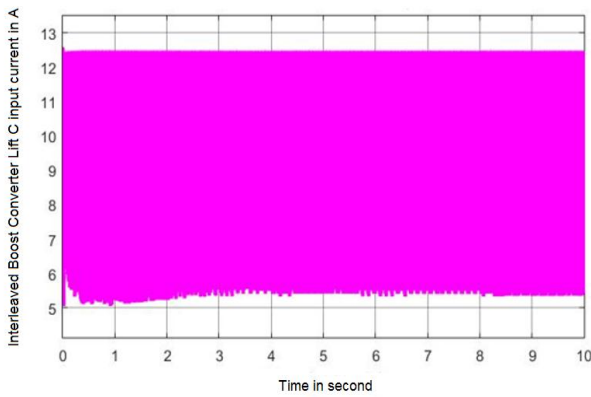

Figure 25. IBC Lift C input current waveform

Table 2. Comparison of Output Voltage

Irradiation(W/m ²)	V _{IBC} (V)	V _{IBC Lift C} (V)
400	351.7	350.7
450	372.9	363.3
500	392.8	381.7
550	405.5	398.8
600	422	415.1
650	438.3	427
700	451.3	433.3
750	464.8	449.6
800	477.9	470.6

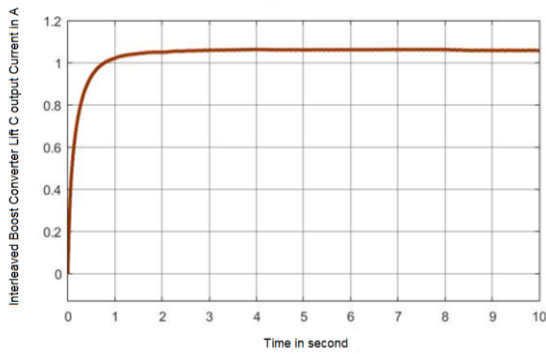

Figure 26. IBC Lift C output current waveform

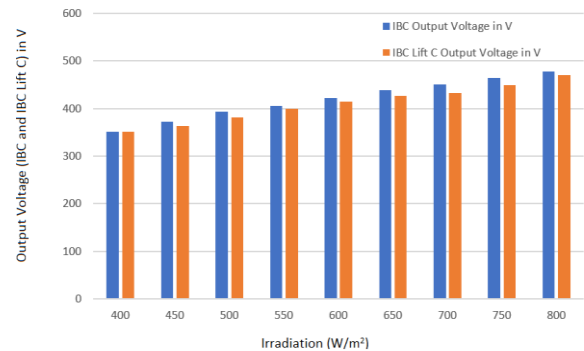

Figure 29. IBC and IBC Lift C output voltage Comparison

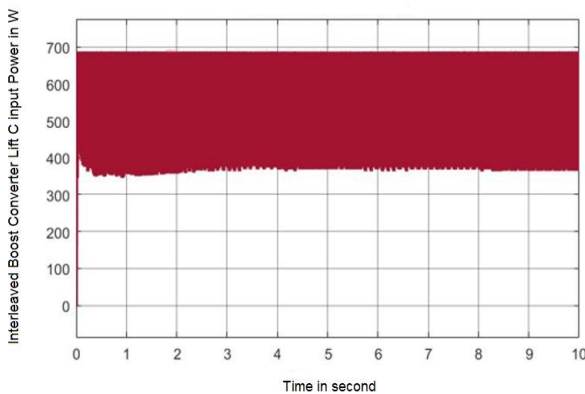

Figure 27. IBC Lift C input power waveform

Table 3. Comparison of Output Power

Irradiation(W/m ²)	P _{IBC} (W)	P _{IBC Lift C} (W)
400	277.3	276.5
450	311.8	299.8
500	346	332.4
550	370.2	358.6
600	397.5	383.6
650	427.7	405.1
700	455.1	433.8
750	484.1	451.7
800	510.1	501.5

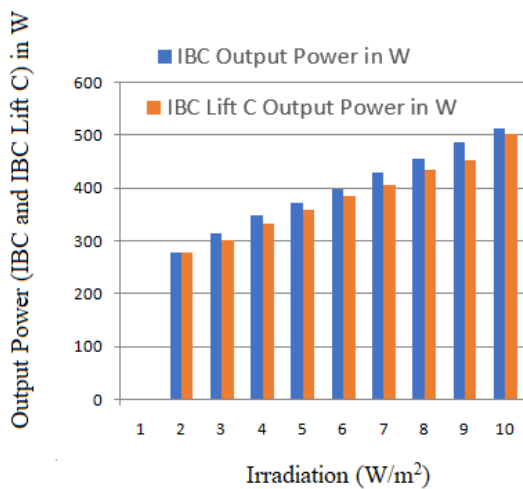

Figure 30. IBC and IBC Lift C output power Comparison

The ripple content almost diminished in the simulation of IBC and IBC Lift C methods. When these two methods are compared the power losses is minimum in the IBC method so that attained maximum power reached as the same time quickly settles at steady state.

margin in this template measures proportionately more than is customary. This measurement and others are deliberate, using specifications that anticipate your paper as one part of the entire proceedings, and not as an independent document. Please do not revise any of the current designations.

Conclusion

In this paper comparative analysis of the two methods IBC and IBC Lift C is done with help of MATLAB/ Simulink. The performance of all methods is analyzed. The P&O technique is employed for solar PV module using the above methods at various irradiances at constant temperature. The IBC method has higher output voltage when compared with boost and IBC Lift C method of same input voltage and duty cycle. For the comparative table irradiation decrease output power also decreases. The solar PV systems maximum power obtained to the available maximum output power with help of MPPT method. IBC maximum power 510.1 W and IBC Lift C maximum power 501.5 W. The performance of solar PV system IBC proposed method produces better results when compared other two methods. The maximum power tracking is more stable for IBC and IBC Lift C compare with BC in relate to the performance, oscillation and stability of photovoltaic systems.

References

- [1] Coelho, F. Roberto, Filipe Concer and Denizar C. Martins, "A study of the basic DC-DC converters applied in maximum power point tracking," In 2009 Brazilian power electronics conference, IEEE, pp. 673-678, 2009.
- [2] Femia, Nicola, Giovanni Petrone, Giovanni Spagnuolo and Massimo Vitelli, "Optimization of perturb and observe maximum power point tracking method," IEEE transactions on power electronics 20, no. 4, pp.963-973,2005.
- [3] Esram, Trishan and Patrick L. Chapman, "Comparison of photovoltaic array maximum power point tracking techniques." IEEE Transactions on energy conversion 22, no. 2, pp.439-449, 2007.
- [4] S. L. Brunton, C. W. Rowley, S. R. Kulkarni and C. Clarkson, "Maximum power point tracking for photovoltaic optimization using ripple-based extremum seeking control," IEEE Transactions on Power Electronics, vol. 25, no. 10, pp. 2531–2540, 2010.
- [5] Kok Soon, Tey, Saad Mekhilef and Azadeh Safari, "Simple and low cost incremental conductance maximum power point tracking using buck-boost converter," journal of renewable and sustainable energy 5, no. 2, pp.023106, 2013.
- [6] Konstantopoulos, Christos, and Eftichios Koutroulis, "Global maximum power point tracking of flexible photovoltaic modules," IEEE transactions on Power Electronics 29, no. 6, p. 2817-2828, 2013.
- [7] L. Gil-Antonio, M. B. Saldivar-Marquez and O. Portillo-Rodriguez, "Maximum power point tracking techniques in photovoltaic systems: A brief review," 13th International Conference on Power Electronics (CIEP),IEEE, pp. 317-322, June 2016.
- [8] Malek and Y. Q. Chen, "BICO MPPT: a faster maximum power point tracker and its application for photovoltaic panels," International Journal of Photoenergy, vol. 2014, Article ID 586503, 9 pages, 2014.
- [9] Soon, Tey Kok and Saad Mekhilef, "A fast-converging MPPT technique for photovoltaic system under fast-varying solar irradiation and load resistance," IEEE transactions on industrial informatics 11, no. 1, pp.76-186, 2014.

- [10] B. Hauke, "Basic calculation of a boost converter's power stage," Texas Instruments, Application Report, pp.1-9, 2009.
- [11] J. Dawidziuk, "Review and comparison of high efficiency high power boost DC/DC converters for photovoltaic applications," Bulletin of the Polish Academy of Sciences. Technical Sciences 59, no. 4, pp. 499-506, 2011.
- [12] Boujelben, Nesrine, Ferdaous Masmoudi, Mohamed Djemel and Nabil Derbel, "Design and comparison of quadratic boost and double cascade boost converters with boost converter," In 2017 14th International Multi-Conference on Systems, Signals & Devices (SSD) IEEE, pp. 245-252, 2017.
- [13] Dahono, A. Pekik, Slamet Riyadi, Ahmad Mudawari and Yanuarsyah Haroen, "Output ripple analysis of multiphase DC-DC converters," In Proceedings of the IEEE 1999 International Conference on Power Electronics and Drive Systems. PEDS'99 (Cat. No. 99TH8475), vol. 2, pp. 626-631, 1999.
- [14] Benavides, D. Nicholas and Patrick L. Chapman, "Modeling the effect of voltage ripple on the power output of photovoltaic modules," IEEE Transactions on Industrial Electronics 55, no. 7, pp. 2638-2643, 2008.
- [15] Hosoki, Ryuga and Hirotaka Koizumi, "High-step-up dc-dc converter using voltage multiplier cell with ripple free input current," In IECON 2013-39th Annual Conference of the IEEE Industrial Electronics Society, pp. 834-839, 2013.
- [16] G. Kishor, D. Subbarayudu and S. Sivanagaraju, "Multiphase Boost Converter with Reduced Input Current Ripple Using Direct Coupled Inductors," International Journal of Engineering Research and Applications, vol. 4, no. 2, pp. 274-279, February 2014.
- [17] J. Wang, W. G. Dunford and K. Mauch, "A comparison of modified boost converters with continuous inductor current mode and ripple free input current with conventional converters," in Conf. Rec. IEEE-IAS Annu. Meeting, vol. 2, San Diego, CA, pp. 878-885, October 1996.
- [18] D. K. W. Cheng, X. C. Liu and Y. S. Lee, "A new modified boost converter with ripple free input current by using coupled inductors," in Proc. IEE Int. Conf. Power Electronics and Variable Speed Drives, London, U.K (IEE Conf. Publ. No. 456), pp. 592-599, September 1998.
- [19] Boris Axelrod, Yefim Berkovich and Adrian Ioinovici, "Switched capacitor/switched-inductor structures for getting transformerless hybrid dc-dc pwm converters," IEEE Transactions on Circuits and Systems I: Regular Papers, vol. 55, no. 2, pp. 687-696, 2008.
- [20] Slah, Farhani, Amari Mansour, Marzougui Hajer and Bacha Faouzi, "Analysis, modeling and implementation of an interleaved boost DC-DC converter for fuel cell used in electric vehicle," International journal of hydrogen energy 42, no. 48, pp. 28852-28864, 2017.
- [21] G. A. L. Henn, R. N. A. L. Silva, P. P. Praca, L. H. S. C. Barreto and D. S. Oliveira, "Interleaved-boost converter with high voltage gain," IEEE transactions on power electronics 25, no. 11, pp. 2753-2761, 2010.
- [22] Valdez-Resendiz, E. Jesus, Abraham Claudio-Sanchez, Gerardo V. Guerrero-Ramirez, Carlos Aguilar-Castillo, Alejandro Tapia-Hernandez and Josefa Gordillo-Estrada, "Interleaved high-gain boost converter with low input-current ripple for fuel cell electric vehicle applications," In 2013 International Conference on Connected Vehicles and Expo (ICCVE), pp. 812-817, 2013.
- [23] Jae-Hyung Kim, Yong-Chae Jung, Su-Won Lee, Tae-Won Lee and Chung-Yuen Won, "Power loss analysis of interleaved soft switching boost converter for single-phase PV-PCS," Journal of Power Electronics, Vol. 10, No. 4, July 2010.

- [24] M. S. Jayakumar and G. Ajeesh, "A high efficient high input power factor interleaved boost converter," *International Journal of Electrical and Computer Engineering (IJECE)* vol.2, No.3, pp. 339~344, 2012.
- [25] S. Kamtip and K. Bhumkittipich, "Design and analysis of interleaved boost converter for renewable energy applications," 9th Eco-Energy and Materials Science and Engineering Symposium, Chiang Rai, Thailand 25, May 2011.
- [26] H. Kosai, S. McNeal, Austin Page, Brett Jordan, Jim Scofield and B Ray, "Characterizing the effects of inductor coupling on the performance of an interleaved boost converter," *Proc. CARTS USA 2009*, pp. 237-251, 2009.
- [27] R. Seyezhai, "Analysis and implementation of interleaved boost converter for fuel cell system," *Journal of Electrical and Control Engineering* vol. 2 Iss. 3, pp. 30-34, 2012.
- [28] R Girish Ganesan and M Prabhakar, "Non-isolated high step-up interleaved boost converter," *International Journal of Power Electronics*, vol. 6, no. 3, pp. 288-303, 2014.
- assistant professor, and Associate Professor (2018) in Tagore Engineering College. Currently, working as Assistant Professor in B.S. Abdur Rahman Crescent Institute of Science and Technology, Chennai. She has published over 19 national, international journals and nearly 15 National and international conferences Proceedings. She has Received certificate from World book of record(London) for participating in longest 150 hours conference, Young Educator & Scholar Award in 10th National Teachers' Day Awards 2019 from NFED Association (Coimbatore), Women Researcher Award, Outstanding scientist Award, Innovative Technological Researcher & Dedicated Academician Award (Electrical Engineering) and Best Academics award from BSA Crescent Alumni Association during Hangout 2019. She has guided over 20 UG and PG candidates. She was life Member in 6 Professional Bodies, and acting as reviewer for reputed journals. Her areas of interest are Power quality, harmonic suppression, Active filter control techniques, renewable energy systems, Microgrid, electric vehicle charging systems.

Authors and Affiliations



Suresh Sampath received his Bachelor of Science (Mathematics) from Mehendra Arts and Science College, Kaalippatti, 2007, Bachelors of Engineering in EEE from Government College of Engineering, Salem in 2010 and Masters of Engineering in Power Systems Engineering, CEG, Anna University, Chennai 2012. His fields of interest includes Transmission and distribution, Power System Analysis and Power System Protection. He currently works as Assistant Professor in BSARCIST, Chennai.



Dr. R. Zahira received B.E (Electrical and Electronics Engineering) from University of Madras in 2004, M.E (Power Systems Engineering) from B.S.A. Crescent Engineering College, Anna University, Chennai in 2006 and the Doctoral degree from Anna University in February 2018. Having 14 years of teaching experience, she started her teaching carrier as Lecturer in 2006, Promoted as Assistant professor, senior