

# Biaxial Fatigue Loading System for Electromagnetic Excitation of Wind Turbine Blades

Ying He<sup>1,\*</sup>, Lei Liu<sup>1</sup>, Hao Zhou<sup>2</sup> and Xinshua Chu<sup>1</sup>

<sup>1</sup>Shandong University of Technology, Zibo 255049, China

<sup>2</sup>Sinoma Technology (Funing) Wind Power Blade Co., Ltd. Yancheng 224400, China

\*892089108@qq.com

## Abstract

Based on the shortcomings of the current detection methods for wind power blades, an electromagnetic excitation biaxial fatigue loading system is designed. The loading method mainly adopts the principle of electromagnetic actuators. The loading part is mainly composed of electromagnet cores and coils. The blades exert electromagnetic force to achieve blade vibration. The dual-axis loading can be more in line with the actual working conditions of the blade. Electromagnetic loading mechanisms are installed in the two directions of the blade's waving and swaying respectively, and the electromagnetic force is applied in the two directions of the blade's waving and swaying at the same time. Vibration frequency, so that the vibration reaches the natural frequency of the blade. In addition, the clamping mechanism of the blade is improved, and a mechanical clamping mechanism is designed, which comprehensively uses the ball screw, timing belt, ratchet and came to realize the positioning and clamping of the blade.

## Keywords

Wind Turbine Blade; Electromagnetic Excitation; Biaxial Loading.

## 1. Introduction

With the continuous expansion of the scale of wind turbines, the increase in the number of installed units and the increase in capacity, wind turbine blades, as the power components of the unit, often suffer from defects such as cracking, fracture, delamination and degumming [1], resulting in reduced power generation efficiency of wind turbines and even huge economic loss. Therefore, before the whole machine is assembled, the inspection and certification of the blade is necessary. At present, the domestic detection method is mainly the pendulum resonance type fatigue loading system. This method belongs to uniaxial loading, which does not conform to the actual working conditions of the blade. The weight of the mechanism itself also has a certain influence on the accuracy of the detection results. Meet the inspection requirements of blades. The National Wind Energy Technology Center of the United States uses the hydraulic biaxial loading method to detect wind turbine blades. This detection method is relatively more accurate, but the hydraulic loading method requires more complex hardware and load control, and the test cost is high and the test period is long.

The main purpose of the dual-axis fatigue loading system for electromagnetic excitation of wind turbine blades [2] designed this time is to perform fatigue tests on wind turbine blades, and make certain innovations for the existing structures to better simulate the actual force of the blades. Therefore, the fatigue loading process can reach or be closer to the actual working conditions, and the life of wind turbine blades can be predicted based on the data while improving the accuracy of fatigue testing [3].

## 2. Biaxial Loading Structural Analysis

### 2.1. Overall Design

As shown in Figure.1, the dual-axis fatigue loading system for electromagnetic excitation of wind turbine blades designed this time mainly includes electromagnetic vibration exciters in the swing direction, electromagnetic vibration exciters in the swing direction, blade clamps and transmission mechanisms. The electromagnetic vibration exciter in the two directions of waving and swaying is loaded at the same time to form a biaxial loading system, and the cooperation of the blade clamp and the transmission mechanism can realize the accurate detection of the blade at multiple positions, that is, the full-scale fatigue test of the blade is carried out. Compared with the domestic and foreign research schemes learned in Chapter 1, the designed biaxial fatigue loading system for electromagnetic excitation of wind turbine blades has the advantages of simple installation, high real-time performance and good controllability. The loading method can better simulate the actual working condition of the blade during the loading process, and eliminates the factor that the loading device is installed on the blade, which affects the detection result of the blade due to the weight of the device itself, and improves the accuracy of blade detection [4], laying the foundation for more accurate prediction of blade service life. The overall structure is shown in Figure. 2.

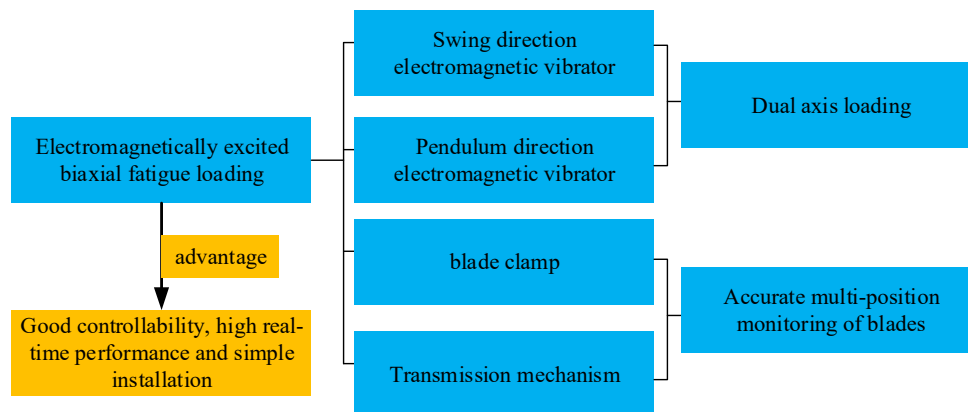

Fig 1. Overall program analysis

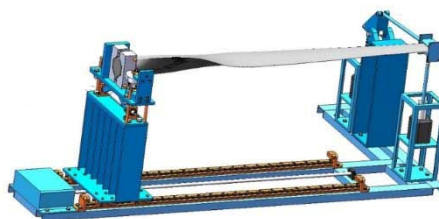

Fig 2. Biaxial fatigue loading system for electromagnetic excitation of wind turbine blades

### 2.2. Blade Clamping Jacking Mechanism

The blade clamping and jacking mechanism is the blade clamp part, including a mechanical clamping mechanism and a jacking and fine-tuning mechanism. The main function of this mechanism is to fix and clamp the blade, and to fine-tune the height of the blade according to the actual situation.

As shown in Figure.3, the blade clamping and jacking mechanism mainly includes a threaded shaft, a camshaft, a cam, a ratchet, a pawl and a V-shaped block. The mechanism pushes the V-

shaped block to clamp the blade through the cam rotation. The ratchet pawl mechanism on the lower part of the cam can prevent the cam from reversing and cause the V-shaped block to loosen. When the cam returns, the spring between the two V-shaped blocks will move the V-shaped block. The block is pushed out to ensure that the V-block is in close contact with the cam. The lifting and fine-tuning part draws on the structure of the mechanical jack, and the mechanism is slightly lifted through the cooperation of the two opposite threads on the shaft and the nut.

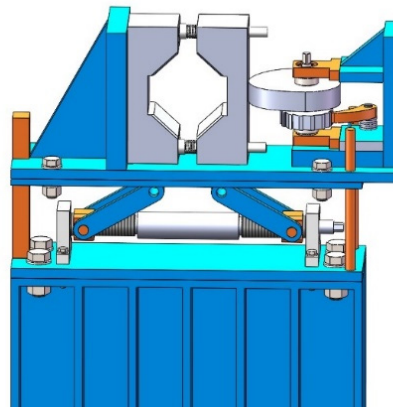
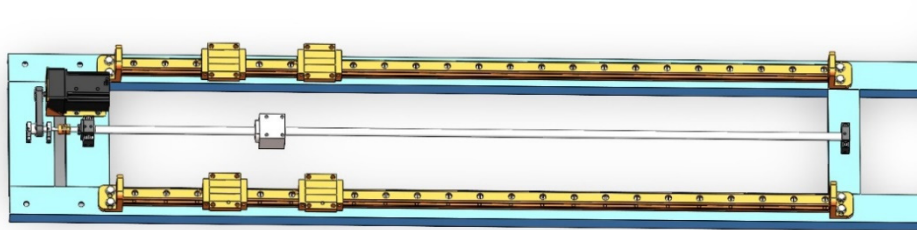

**Fig 3.** Blade clamping jacking mechanism

**2.3. Screw Drive Mechanism**

The screw drive mechanism mainly includes synchronous belt drive and ball screw drive. The main function of this mechanism is to load and test multiple points of the blade by adjusting the position of the wind turbine blade in the horizontal direction.

As shown in Figure.4, the screw drive mechanism mainly includes a stepper motor, a synchronous pulley, a synchronous belt, a screw drive shaft, a coupling, a ball screw and a slide rail. The mechanism mainly adopts a ball screw mechanism. The stepping gear motor transmits the torque to the shaft through the synchronous belt mechanism, and then transmits the torque on the shaft to the lead screw through the coupling. The mechanism is displaced in the horizontal direction, and limit devices are installed on both sides of the slide rail to limit the protection of the upper mechanism.



**Fig 4.** Screw drive mechanism

**2.4. Dual-axis Electromagnetic Loading Mechanism**

The biaxial electromagnetic loading mechanism includes an electromagnetic loading mechanism in the blade swing direction and an electromagnetic loading mechanism in the blade swing direction. The main function of this mechanism is to perform biaxial loading on the wind turbine blades.

As shown in Figur.5, the electromagnetic loading mechanism in the two directions of blade swing and swing mainly includes an electromagnet core, a coil, a guide rod and a direction conversion mechanism. The mechanism controls the vibration of the iron core by controlling

the on-off of the coil, and the iron core will transmit the electromagnetic force to the blade through the guide rod, thereby realizing the biaxial loading of the blade. In addition, the electromagnetic loading methods also include one-way loading and two-way loading. When one-way loading, the efficiency of blade loading is higher, but the work done by the electromagnetic force is small. When two-way loading, the electromagnetic force is symmetrical loading, the work done by the electromagnetic is larger, but the number of times the coil is turned on and off is doubled, resulting in more energy loss and lower efficiency. An appropriate loading method can be selected according to the actual loading situation.

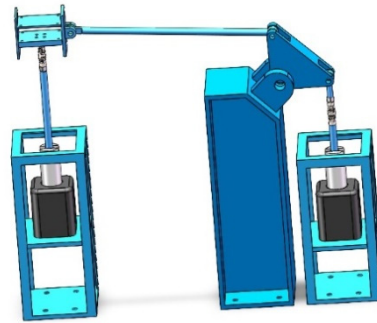

**Fig 5.** Dual-axis electromagnetic loading mechanism

### 3. Conclusion

This time, a biaxial fatigue loading system for electromagnetic excitation of wind turbine blades is proposed. According to the currently known loading schemes, for single-axis loading schemes, such as single-pendulum centrifugal loading, single-axis electromagnetic pulse loading, etc., the main problem lies in that the blade can only be loaded in one direction, and the loading process cannot be well adhered to. The actual working conditions of the blade are closely related, resulting in a lower accuracy of the results of the blade fatigue detection. For such problems, this design proposes a dual-axis loading mechanism, which simultaneously loads the blades in the two directions of waving and swinging arrays, so that the loading process is more in line with the actual working conditions of the blades and improves the efficiency of the blades. The accuracy of the test results lays the foundation for better prediction of the service life of the blade. At present, there are also dual-axis loading schemes. For such schemes, such as electric-driven dual-inertia fatigue recording, dual-pendulum fatigue loading, and hydraulic-driven dual-axis loading devices, the main problem lies in the direct installation of the loading device on the blade. The weight of the device itself will have an impact on the detection results of the blades, while for the hydraulically driven loading device, the detection results are relatively more accurate, but the requirements for hardware and control are relatively high, and the test cost is high.

For such problems, this design proposes a loading method of electromagnetic excitation. The electromagnetic core and coil are used to apply electromagnetic force to the blade to control the blade vibration. The electromagnetic loading method has a simple structure, good controllability and high real-time performance. In addition, this design also designs a mechanical clamping structure for the blade clamp, which uses V-shaped blocks for positioning and clamping. For the full-scale fatigue detection of the blade, for the horizontal and vertical directions of the blade, ball wire is used. The lever mechanism, timing belt mechanism and jack mechanism can fine-tune the position of the blades.

## Acknowledgments

Natural Science Foundation.

## References

- [1] Tian S, Wei S, Chenyu D. Damage identification of wind turbine blades based on dynamic characteristics [J]. *Nonlinear Engineering*, 2022, 11(1): 98-107.
- [2] Weifei H, Wentao Z, Yeqing W. Design optimization of composite wind turbine blades considering tortuous lightning strike and non-proportional multi-axial fatigue damage [J]. *Engineering Optimization*, 2019, 52(11): 133-121.
- [3] SEPIDEH A, MOHAMMADREZA H, SHAMS T. Life prediction of wind turbine blades using multi-scale damage model [J]. *Journal of Reinforced Plastics and Composites*, 2021, 40: 65-73.
- [4] ZHANG J, SHI K, LI X. Using a two-stage approach to improving accuracy of resonance fatigue tests for large-scale wind turbine blades [J]. *Journal of Renewable and Sustainable Energy*, 2019, 11(4): 77-80.