

welded at the side end center of the second sliding key, the nut thread is inserted on the screw rod, the support frame includes cover plate, support rod, inserting rod, auxiliary wheel and limit pin, the cover plate is fixedly welded on the support rod, and the auxiliary wheel is symmetrically fixed and fixed inside the support rod, The sliding chute is arranged at the top of the supporting rod and the inner top of the cover plate, the inserting rod is symmetrically fixed and welded at the bottom of both ends of the supporting rod, the fixed foot includes the limit bolt, the fastening screw and the bottom plate, the limit bolt is sliding inserted on the side end of the bottom plate, and the fastening screw is inserted symmetrically at the bottom end of the bottom plate.

The inner part of the bottom plate is provided with a slot which is matched with the limit bolt and the supporting rod, and when the supporting rod drops to the limit position, the inserting rod is sliding inserted into the interior of the bottom plate.

The top of the cover plate is provided with a water channel, and the side end of the support rod is engraved with a scale line.

A square groove matched with the second sliding key and the screw rod is arranged inside the two ends of the support rod, and the nut is fixed with the cross frame and the support rod when the nut is screwed inward to the limit position.

The inner part of the outer cover is fixedly connected with a motor, and when the gear rotates to the limit position, it contacts with the buffer strip.

The inner material of the buffer strip is rubber.

The two ends of the cross frame are provided with a moving groove matched with the supporting rod.

3. Design Schematic Diagram

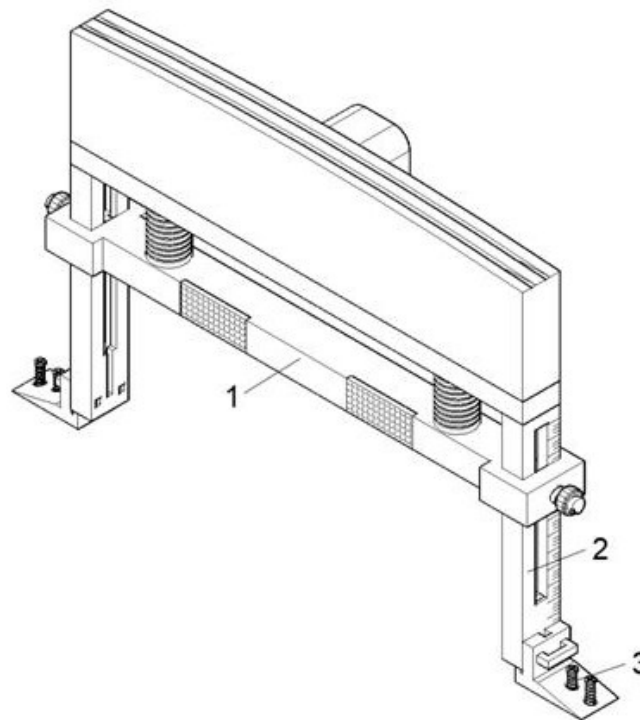

Figure 1. Shows the main structure of the project

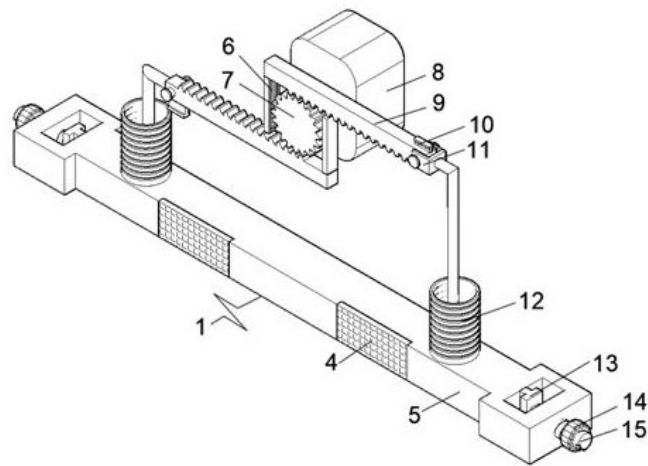

Figure 2. Is the structural diagram of the lifting rod of this project

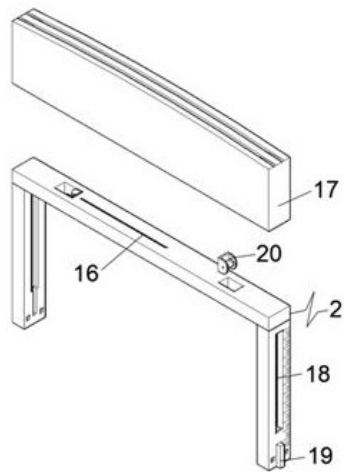

Figure 3. The structural diagram of support of this project is shown

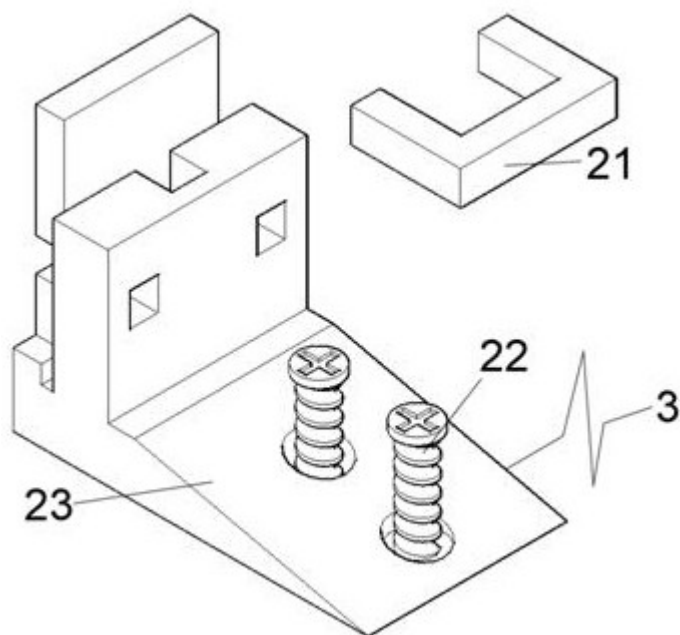

Figure 4. Shows the structure of the fixed foot of this project

In the figure: 1-lifting rod, 2-support frame, 3-fixed foot, 4-reflector, 5-transverse frame, 6-buffer strip, 7-gear, 8-cover, 9-rack, 10-first sliding key, 11-wire rope, 12-bellows, 13-second sliding key, 14-nut, 15-screw, 16-chute, 17-cover plate, 18-support rod, 19-plug-in, 20-auxiliary wheel, 21-limit bolt, 22-fastening screw, 23-bottom plate.

4. Specific Implementation Mode

Please refer to figure 1-4. An implementation example of the project is provided: a height adjustable road height limit rod, including a support frame and a chute. The internal sliding of the support frame is connected with a lifting rod, and the bottom end of the support frame is symmetrically clamped with fixed feet. The lifting rod includes a reflective plate, a cross frame, a buffer strip, a gear, a cover, a rack, a first sliding key, a steel wire rope, a corrugated pipe, a second sliding key, a steel wire rope, a corrugated pipe, a second sliding key, a fixed foot. The first sliding key is symmetrically fixed and welded on the rack, the steel wire rope is rotated and connected to the center of one end of the rack, the cross frame is fixedly connected to the bottom end of the steel wire rope, and the corrugated pipe is symmetrically fixed and fixed on the cross frame. The reflector is symmetrically fixed and connected to the side end of the cross frame, the second sliding key is symmetrically fixed and welded inside the two ends of the cross frame, the screw is fixedly welded at the side end center of the second sliding key, the nut thread is inserted on the screw rod, the support frame includes cover plate, support rod, inserting rod, auxiliary wheel and limit pin, the cover plate is fixedly welded on the support rod, and the auxiliary wheel is symmetrically fixed and fixed inside the support rod. The sliding chute is arranged at the top of the supporting rod and the inner top of the cover plate, the inserting rod is symmetrically fixed and welded at the bottom of both ends of the supporting rod, the fixed foot includes the limit bolt, the fastening screw and the bottom plate, the limit bolt is sliding inserted on the side end of the bottom plate, and the fastening screw is inserted symmetrically at the bottom end of the bottom plate.

When the support rod drops to the limit position, the inserting rod slides into the inner part of the bottom plate, the top of the cover plate is provided with a water groove, and the side end of the supporting rod is engraved with a scale line, and the two ends of the support rod are provided with square grooves matching with the second sliding key and the screw. The inner part of the outer cover is fixedly connected with a motor, and the gear wheel is in contact with the buffer strip when the gear rotates to the limit position. The inner material of the buffer strip is rubber. The two ends of the cross frame are provided with a moving slot which is suitable for the support rod. The inner part of the outer cover is installed with a motor, and the gear is fixed on the motor to start the motor. It can drive the gear to rotate. When the gear rotates, it can drive the rack meshed with the gear to move. The internal material through the buffer strip is rubber, so as to avoid steel collision with the gear when the gear drives the rack to move to the extreme position. The rack is connected to one end of the rack through the wire rope rotation, and the cross frame is fixedly connected to the bottom end of the wire rope. It can drive the steel wire rope to pull the transom to move upward, so that the height of the cross frame can be flexibly adjusted. The screw rod is fixedly connected to the side end of the second sliding key, and the nut can be screwed inward until it is fixed with the side end of the cross frame, so as to drive the cross frame and the support rod to be fixed and connected between the cross frame and the support rod through the corrugated pipe. Moreover, the corrugated pipe is located on the outer ring of the steel wire rope, so as to protect the steel wire rope from rain, so as to avoid corrosion and fracture. It is symmetrically fixed and connected in the inner part of the supporting rod through the auxiliary wheel. When the steel wire rope is rising or falling, it can pass through the inner end of the auxiliary wheel, so that the steel wire rope can finish the work more smoothly with the steel wire rope. The rainwater will not accumulate on the top of the

cover plate, so as to avoid the moisture regain of the internal parts. The scale line is engraved on the side end of the support rod, so that the falling distance can be accurately controlled. Through the side end of the bottom plate, a slot matching with the limit bolt and the support rod is opened, and the limit bolt can be successively inserted into the side end of the bottom plate and the support rod, so that the support rod can be fixed on the bottom plate, Thus, the support rod can be quickly removed and installed.

5. Working Principle

The user places the bottom plate 23 at the designated position in advance, and then the fastening screw 22 is symmetrically threaded through the bottom plate 23 to fasten with the ground. Through the slot matching with the limit bolt 21 and the support rod 18, the support rod 18 can be slidingly inserted on the bottom plate 23, and then the limit bolt 21 is successively penetrated through the bottom plate 23 and the support rod 18, so that the support rod 18 can be fixed at the same time, When the gear 7 is rotating, the rack 9 can be driven to move, and the rack 9 can drive the steel wire rope 11 and the cross frame 5 to move up and down, so that the height of the cross frame 5 can be flexibly adjusted, and the first sliding key 10 is symmetrically fixed and connected to the rack 9, The chute 16 is symmetrically arranged on the top of the support rod 18 and the inner top of the cover plate 17. The first sliding key 10 can be slidably clamped to the inside of the chute 16, so that the rack 9 can be ensured to move along a straight line, thus avoiding the inclination of the steel wire rope 11 when it is pulled up. A scale line is engraved on the side end of the support rod 18, so that the moving distance of the cross frame 5 can be accurately controlled, Then screw the nut 14 symmetrically inward until the cross frame 5 is fixed with the support rod 18, so that the cross frame 5 can be fixed at the specified height, and is fixedly connected between the cross frame 5 and the support rod 18 through the corrugated pipe 12, and the corrugated pipe 12 is located in the outer ring of the steel wire rope 11, which can prevent the steel wire rope 11 from being wet by rain, thus greatly improving the service life of the steel wire rope 11.

6. Pioneering Point

In this project, a motor is installed inside the outer cover, and the gear is fixed on the motor. The motor can be started by power on to drive the gear to rotate. When the gear rotates, it can drive the rack meshed with the gear to move. The internal material of the buffer strip is rubber, so as to avoid steel collision with the gear when the rack moves to the limit position, Therefore, when the steel wire rope is screwed on the bottom of the rack frame, the movable end of the steel wire rope can be pulled on the bottom of the steel wire rack, so that the movable end of the steel wire rope connected with the steel wire frame can be rotated through the fixed end of the steel wire frame, Therefore, the cross frame can be driven to fasten with the supporting rod, so as to share part of the gravity of the cross frame. The corrugated pipe is fixed and connected between the cross frame and the support rod through the corrugated pipe, and the corrugated pipe is located on the outer ring of the steel wire rope, so as to protect the steel wire rope from rain, so as to avoid corrosion and fracture, It can pass through the inner end of the auxiliary wheel, so that the steel wire rope can finish the work more smoothly. There is a water groove on the top of the cover plate, so that the rainwater will not accumulate on the top of the cover plate, so as to avoid the moisture regain of the internal parts. The scale line is engraved on the side end of the support rod, so that the falling distance can be accurately controlled, The side end of the bottom plate is provided with a slot matching with the limit bolt and the support rod, and the limit bolt can be inserted into the side end of the bottom plate and the support rod in turn, so that the support rod can be fixed on the bottom plate, so that the support rod can be quickly disassembled and installed.

Acknowledgments

Liaoning University of science and technology 2022 innovation and entrepreneurship training program project funding.

References

- [1] Research on optimizing the management of road height limit pole [J]Li Jingang, Yan XingpeiRoad traffic management2021(02).
- [2] The big business behind the number of road height limit poles [J]Zhao FengBusiness observation 2021 (08).
- [3] Solve the contradiction between height limit and safety, and avoid the height limit pole becoming a "Life Killing pole" [J]Chinese highway2021(10).
- [4] On the transformation design of city high pole lamp [J]Du YongbangShanxi architecture2012(11).
- [5] Analysis of intelligent control system of wharf high pole lamp [J]Zou AoqingThe world of communication 2015(12).
- [6] Transformation of high pole lamp in coal yardWu PengPort technology2011(03).
- [7] Driving without observing the height limit bar [J]Zhang LeiDriving garden2012(07).
- [8] Transformation of high pole lamp in coal terminal yard [J]Yin GangPort technology 2015 (05).
- [9] Intelligent control of port high pole lamp [J]Tang LiPort handling2013(05).
- [10] Design points and application based on the height of road height limit pole [J]Chen Zhuo, Li PingLow carbon world2019 (07).