

# Design of PM2.5 Measurement and Alarm System based on STM32

Liqun Shao

Suzhou Industrial Vocational and Technical College, Suzhou, Jiangsu, 215104, China

## Abstract

The rapid development of high-tech has brought a lot of convenience to people's life and work, especially the single-chip technology, which is widely used in many sensing devices, and is becoming increasingly miniaturized and diversified. This design mainly uses STM32 single chip microcomputer as the core board, uses GP2Y dust sensor to collect PM data in the tested environment, sends the collected data to STM32 core board, uses the control function of the chip to calculate and process its data, and transmits it to the display to display the data. This design can facilitate people to detect the air quality of the surrounding environment at any time, improve people's surrounding environment and improve their physical fitness.

## Keywords

STM32 Microcontroller; Dust Sensor; PM2.5.

## 1. Introduction

With the development of the times and the progress of science and technology, people's quality of life is continuously improving, but at the same time, the content of various toxic gases in the air is also continuously increasing, such as PM2.5, PM0.3, PM0.1 and other toxic gases in the air affect our breathing problems, causing certain harm to our lives and health[1].

This system uses STM single chip microcomputer control technology and GP2Y dust sensor sensing technology to measure the content of PM2.5 in the environment. Through the detection of PM value in the tested surrounding environment, the collected data is converted and calculated, the data is read, and then displayed on the display screen.

## 2. Circuit Design

### 2.1. Circuit Overall Design

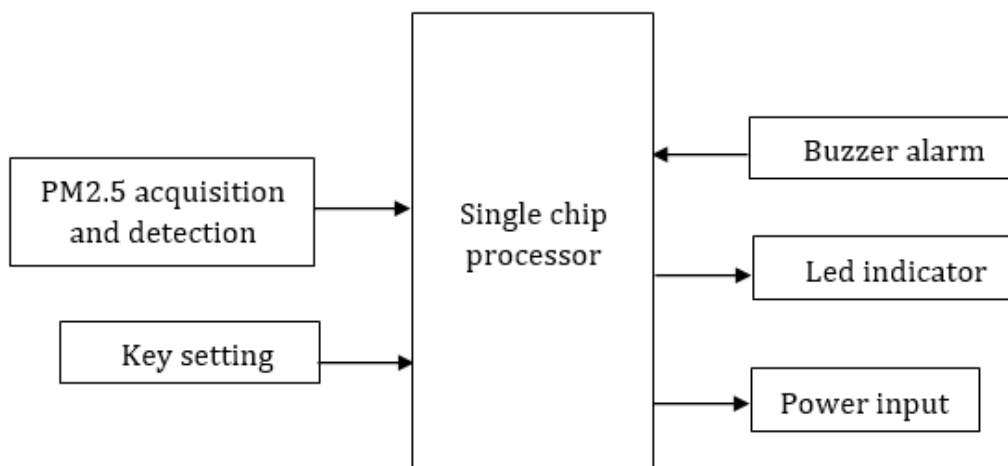

Figure 1. System Framework

This design collects PM2.5 data in the tested environment through PM2.5 dust sensor, converts the collected analog information into digital information, and transmits the data information to the control circuit for analysis and processing, and finally presents the current data we measured through the LCD. The system framework is shown in [Figure 1](#).

Function of each module: PM2.5 acquisition module mainly collects PM2.5 concentration index in the tested environment; Key module - mainly used to set the concentration of PM2.5; Buzzer alarm module - alarm function is realized when the design upper limit value is exceeded; LCD display module - mainly displays the currently collected PM2.5 concentration value and the upper limit value to be set; Control module - mainly uses STM microcontroller to calculate the transmitted data and convert it into digital signal for output[2,3].

### 2.2. Power Supply Circuit Design

The VCC uses a DC regulated power supply of 5V. The SWITCH is a self-locking switch and the POWER is the power input terminal. Press the key to output the power. The schematic diagram is shown in [Figure 2](#).

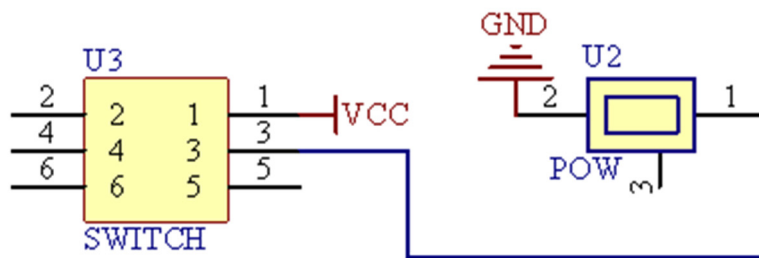

Figure 2. Power supply circuit

### 2.3. Acquisition Circuit Design

This system is generally presented on a PC, which combines the system hardware, system software and computer processing system to measure the corresponding data. The whole system function of the acquisition circuit is to complete the data acquisition and signal regulation. The collection circuit uses Sharp's second generation GP2Y1051A0F dust sensor, which can detect smoke, dust and other small particles in advance[4]. The sensor can be powered by a single power supply, and it is relatively simple and convenient to install. This design collects PM2.5 particles in the measured air through it, and sends them to the microcontroller for processing after AD conversion. The schematic diagram is shown in [Figure 3](#).

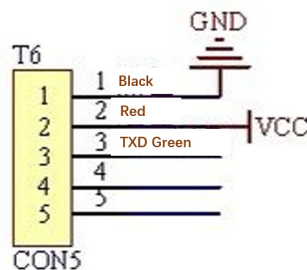
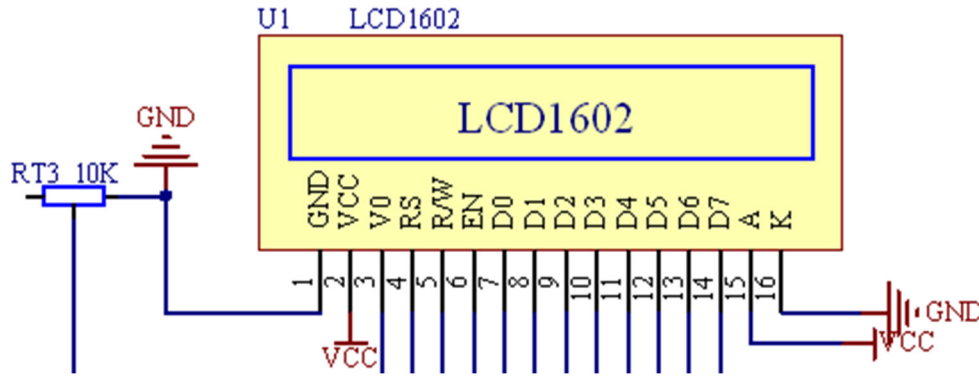

Figure 3. Acquisition circuit

### 2.4. LCD Circuit Design

The LCD module mainly displays the PM2.5 content data processed by the MCU on the fluorescent screen in digital form. This data is the concentration of PM2.5 in the tested environment. The schematic diagram of LCD is shown in [Figure 4](#).



**Figure 4.** LCD display circuit

There are two connection modes between LCD1602 and STM32, namely direct connection and indirect connection. The difference between them is the number of data lines, but the functions are the same. Now the liquid crystal display is digital, and the connection with the microcontroller is also very simple and convenient.

### 2.5. Design of luminous Alarm Circuit

The alarm circuit triode adopts S8050 model, which is NPN triode, and can also be used as a switch in general[5]. Because this design uses the STM32 microcontroller, its back pin is connected to the low level by default, and the schematic diagram is shown in [Figure 5](#).

The core board of this design is STM32. After the microcontroller is powered on, its back pin defaults to low level. In this design, 8050 is used instead of S8550, because S8550 is low level conduction. If buzzer alarm is required, it should be like S8050 high level conduction transistor. The buzzer and LED are used to realize the alarm function. The buzzer adopts the model of TMB12A05, which is an active integrated long sounding buzzer with a voltage of 5v. The LED is a red ordinary LED lamp. In order to limit the current, an additional resistance of 1 kilohm is added to the circuit.

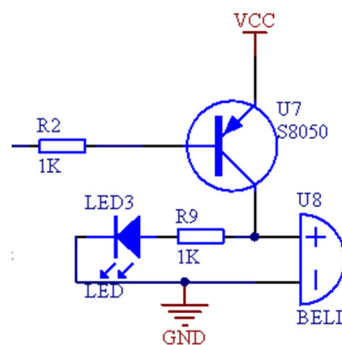

**Figure 5.** Alarm circuit

K1 and K2 are keys; The key is mainly used to set the upper limit value. If the detected PM2.5 value exceeds the set upper limit value, the alarm will give an alarm and the LED will light up. The schematic diagram is shown in Figure 6. When K1 is pressed, the upper limit value of PM2.5 increases, and when K2 is pressed, the upper limit value of PM2.5 decreases.

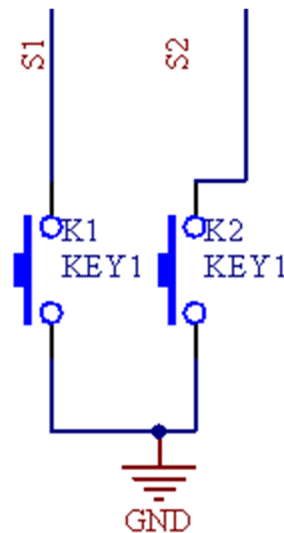

Figure 6. Key circuit

## 2.6. The Design of the Minimum System of Single Chip Microcomputer

Single chip microcomputer system is generally used for control system, which is an important part of microcomputer[6]. It consists of main chip, power on reset circuit, clock circuit and power supply circuit. Generally, we put it in the control circuit to control. The single chip microcomputer is mainly composed of integrated circuits with internal single blocks. The most important part of the interior includes the CPU processing chip, IO port and memory. Model STM32F103C8T6 MCU is the core board of this design. This type of microcontroller is a microprocessor with high performance and low power consumption. Its operation method is very simple and convenient. Its function is to control various sensors and peripherals, and then calculate and process to obtain the corresponding data and signals, and finally make relevant operations. Although it plays a brain role in industry, it can only handle some simple control tasks. In our life, the application of single chip microcomputer is very extensive, such as air purifier, intelligent fan, water heater, computer and monitor, and many intelligent appliances will use its functions. Microcontroller is also used in many instruments, industrial and medical equipment. There may be more than one microcontroller on an instrument.

Before STM32, C51 single chip microcomputer was used, but because of the higher and higher requirements for single chip microcomputer, a more advanced single chip microcomputer was produced. The STM32 has much stronger functions than the 51. For example, in terms of running speed, the 51 is not as fast as the STM32, and it has more new control functions. The biggest advantage of STM32 MCU is that it has very powerful communication and control functions. Because C51 single chip microcomputer has only one communication serial port and STM32 single chip microcomputer has five serial ports, STM32 single chip microcomputer is promoted in the whole single chip microcomputer market. The schematic diagram is shown in Figure 7.

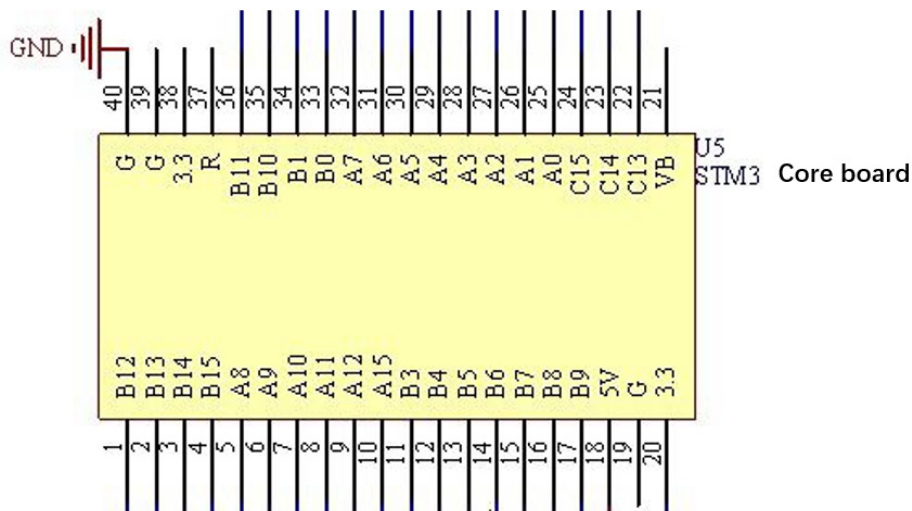

Figure 7. Schematic diagram of single chip microcomputer

### 3. Conclusion

This design is to collect PM2.5 concentration in the tested environment, then digitize the collected analog signal through AD conversion, and finally display the processed data on the LCD. The upper limit of PM2.5 concentration value can be set before measurement. If the PM2.5 concentration value of the measured environment exceeds the upper limit, the alarm circuit will start.

The hardware of the system is realized by STM32 core board, LCD, LED, GP2Y dust sensor and buzzer.

### References

- [1] C. Xie, Z. Wang. Design and Implementation of Indoor Air Quality Monitoring System Based on Single Chip Microcomputer [J] Forestry machinery and woodworking equipment 2020(12).
- [2] G.R.Li, Y.B.Shen, W.H. Wu, H.Q. Liu, Z.Q. Niu. Design and implementation of indoor air quality monitoring device [J] Fujian Computer 2019(04).
- [3] H.Y.Li. Design and implementation of home environment monitoring system based on Android platform [D] Guangdong University of Technology 2016.
- [4] A.B. Xu. Research on indoor air quality detection system [D] Heilongjiang University 2016.
- [5] Y. Xing, Y. Wu., Z.Y. Ji., J. Lu. Environmental Monitoring System Based on Internet of Things Technology [J]. Electronic Technology and Software Engineering 2018(01).
- [6] L.Q. Shao, H.M.Hang. Course of Digital Electronic Technology Project [M]. Electronic Industry Press. 2022.