

Exploration on the Integration of Electronic Product Quality Control

Feng Zhou

Suzhou Vocational Institute of Industrial Technology, Suzhou 215104, China

00285@siit.edu.cn

Abstract

An electronic control system that can realize the functions of detecting and measuring the steps and time display is designed. The design content of the system in this paper is roughly divided into two levels: software and hardware. In the hardware design level, a STC89C51 single chip computer with 8-bit data operation capability is selected, which is used as the main control core of this type of electronic pedometer system. It combines the LCD1602 display A series of high-end devices, such as ADXL345 module and real-time clock chip, have designed the hardware architecture of this electronic pedometer system through efficient and stable circuit layout construction. In terms of software program construction, this graduation design divides the system architecture of this model of electronic pedometer control system into main program and several subprogram modules, Realize the design of each expected functional index of this type of electronic pedometer control system. Finally, after a long test run, the design results of this type of electronic pedometer control system show high efficiency and stability, and a large number of test data show that all indicators meet the initial goals.

Keywords

Multifunctional Pedometer; STC89C51 Single Chip Microcomputer; Acceleration Detection.

1. Introduction

Generally speaking, under the current conditions of scientific and technological development, the implementation scheme of the electronic pedometer control system is mainly completed by using micro controllers such as processor chips as the main control. There are many different types of electronic pedometers in the market today, which follow different use occasions and performance levels. Their efficacy and working accuracy are divided into many kinds, but the core functions are almost the same. Through the research and investigation of a variety of mature design schemes, it can be seen that during the years of development of electronic pedometers, there have been many classic works with excellent performance. At different stages of time, electronic pedometers realized through different schemes have played a great glory. After being brought to the market through continuous improvement and optimization, researchers have been widely favored by users. The development of electronic pedometer control system can not be separated from the common promotion of various technologies, among which microprocessor R&D and control technology, sensor technology, large-scale circuit integration technology and programming technology are the core technologies. At first, the micro controller can only process four bit data. With the attention paid by researchers to the performance of the microprocessor, the microprocessor has experienced eight bit, sixteen bit and 32-bit computers after decades of development. Today's highest performance microprocessors are mainly 32 bit computers. From the perspective of its internal CPU efficiency, in terms of the amount of data computation at a fixed time, compared with the best

eight bit computers, It is directly increased by four times. The improvement and optimization of the instruction cycle have increased the comprehensive execution time of the instruction signal by dozens of times. In many ways, various kinds of optimization items have made the effectiveness of the electronic pedometer obtain great results in recent years. This graduation design will take into account the design funds, energy consumption and effects of the electronic pedometer system and other important factors, try to select the most appropriate micro controller and necessary circuits for this paper, and construct an electronic pedometer system that meets the expected design goals[1-6].

Over the years, both in the mainland and overseas, more and more attention has been paid to the concept of intelligence, especially in the electronic pedometer, which uses a micro controller as the main control system. Because the embedded system is easy to achieve, different types can be easily achieved through program control. According to a magazine published recently, a survey shows that the current research and development achievements of electronic pedometers in the mainland, The gap between the two sides is getting smaller and smaller. At present, domestic colleges and universities are paying more and more attention to the teaching of microprocessor technology and sensor technology. Therefore, many graduates of electronics related majors have the foundation to design electronic pedometers. In order to further master the top technology of designing electronic pedometers in China, much effort is needed.

2. Scheme Design and Component Introduction

For the research and development content of this electronic pedometer system, it is divided into two parts: hardware circuit and software program. The hardware circuit is the most important part. The operating effect and stability of the system hardware will determine the working efficiency and performance of the program design code. Here, first of all, at the hardware level, the implementation scheme of this electronic pedometer system is designed, as shown in the structural block diagram below, STC89C51 single chip microcomputer minimum system will be the key part, through which the control of each peripheral circuit module will be realized.

In terms of the realization scheme of the acceleration detection function in the process of human walking, the subject uses the ADXL345 three-dimensional acceleration sensor module developed by ADI Company, and the STC89C51 microprocessor will connect with this module through its IIC interface to achieve real-time monitoring of the acceleration of the three dimensions of the human body in the process of walking. Once a large acceleration peak is detected, it is considered that the human body has moved a step, Because the ADXL345 three-dimensional acceleration sensor has a very high integration, it does not require too complex circuit configuration, and only needs power supply and IIC connection to complete the drive circuit design.

In terms of the acquisition of Beijing time and date data, this topic uses the DS1302 clock chip module shown in the following figure to connect it with the 51 single chip computer through the three wire serial interface. The single chip computer continuously reads the time and date through the bus, and then sends the read data to the LCD1602 LCD module for display.

The outline diagram of STC89C51 single chip microcomputer is shown in the figure. This model of STC89C51 single chip microcomputer used in this paper belongs to a small and medium-sized capacity configuration, which is suitable for use in electronic systems of this level of electronic pedometer system. It is a FLASH module. The program code can be directly burned through the serial interface. The program language will run from the storage space of 4KB bytes of this model, The effect of STC89C51 single chip microcomputer and the resource configuration of its internal function modules can perfectly meet the application requirements

of the electronic pedometer control system. The first step is its rich internal resource modules. The designer has integrated the 16 bit high-performance timer, serial interface and interrupt trigger resources. In terms of power supply, it can work only through DC5V DC voltage.

In order to see the shadow of LCD1602 LCD screen in most common STC89C51 single-chip microcomputer control systems, in most cases it mainly realizes the function of LCD display under the control of the parallel interface of the processor chip. According to the data display, the internal structure of this display can be clearly seen. It is mainly composed of LCD dot matrix, voltage processor, parallel bus interface, font memory and LCD master controller. It can be seen from the device outline drawing in the following figure that this LCD1602 LCD module has a total of 16 bus pins. Users can drive it only through a simple interface. In normal operation, it has the performance of displaying 32 groups of LCD lattice.

In this paper, ADXL345 is used to measure the acceleration of three mutually perpendicular axes. It is a three-dimensional acceleration sensor with high cost performance. According to the chip manual provided by Risym, after the user completes the circuit design and software control of this type of ADXL345, the ADXL345 can achieve the effect that the acceleration measurement time is less than 1 μ s. This ADXL345 module provides users with a total of 10 pins, as shown in the figure below. These pins are divided into power supply pins and signal pins, namely INT1, INT2, SDO, SDL, SCL, VCC50, VCC33, GND, VSS and CS. This topic will build the circuit according to the function of each pin. This ADXL345 element is a low-power device, which only needs 0.05W power under the working state, It is impossible to consume more power for the electronic pedometer system designed in this paper. Introduction to Real Time Clock Chip.

Considering that this topic needs to build an RTC timing part to achieve the timing goal, we can see from the relevant mature design scheme that DS1302 clock chip is the best one with cost-effective parameters in some middle and high-end microprocessor control systems. It can choose the voltage within the range of +2.5 to 5V for power supply. DC5V will be used in this graduation project, The STC89C51 single-chip microcomputer will drive it through the three wire serial interface. The DS1302 clock module is internally integrated with a circuit module that can automatically measure the time and date. Driven by high-precision low-frequency crystal oscillator, it can automatically measure the time and date with very low error.

3. System Hardware Design

The key part of the minimum system is STC89C51 single chip microcomputer chip, reset circuit and clock signal circuit. This circuit is the most important part of all electronic pedometer control systems, and its circuit structure is also the most simple. However, in order to maintain a stable and high-speed operation of the electronic pedometer system, it is necessary to ensure the accuracy of this circuit. Next, the reset circuit and clock circuit will be designed.

The reset circuit is connected to the RST pin RST of the STC89C51 single-chip microcomputer in the minimum system. According to the line connection relationship in the figure, the 10k ohm resistor is directly connected to the 10 μ F capacitor, and the power is supplied through the VCC DC voltage. The function of the key is for the user to manually reset. The working principle of this device can be described as follows: under normal working conditions, the voltage at both ends of the capacitor is VCC because of the capacitance's isolation effect, and the RST pin receives a high level, STC89C51 single chip microcomputer can work stably, but the capacitor is short circuited when the user presses the key, so there is no voltage at both ends of the capacitor. At this time, the RST pin receives the low-level system reset. As shown in Figure 1.

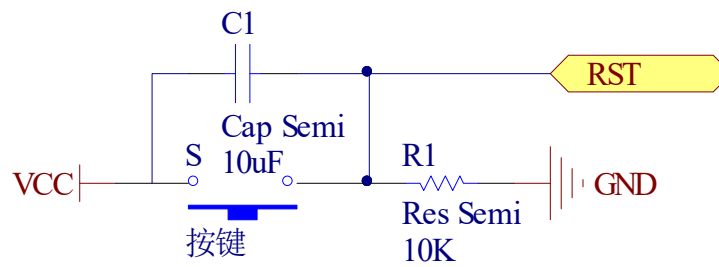

Figure 1. Reset Circuit Design

The clock circuit is an indispensable part of the minimum system. As shown in the figure below, this circuit can be composed of only three devices. To achieve the fast data processing speed and high stability of STC89C51 single-chip microcomputer, a 12MHz crystal oscillator is selected to design this circuit after a compromise. After two identical 30pF capacitors are connected, this circuit can start up quickly after power on, so as to realize the normal operation of the clock frequency signal, This circuit is directly connected with XTAL1 and XTAL2 pins of STC89C51 single-chip microcomputer. As shown in Figure 2.

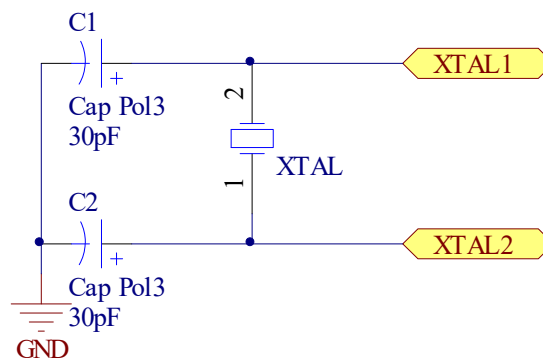

Figure 2. Clock Circuit Design

The LCD1602 LCD screen used in this topic uses the parallel interface type, so the configuration of GPIO pin resources of the STC89C51 microcontroller needs to be considered when designing the hardware circuit, which will determine the performance indicators of all LCD functions. At the same time, on the hardware layer, the STC89C51 microcontroller needs to control RS, RW, EN and DB0~DB7 of the LCD1602 LCD screen, as shown in the circuit schematic diagram below, As long as the VCC end of the VCC system voltage is connected to the power pin of the LCD1602 LCD screen, in terms of data interaction circuit configuration, the R&D manufacturer leads out the 11 pins used for data transmission, in which the parallel mode is used for data interaction interface with the processor chip. As shown in Figure 3.

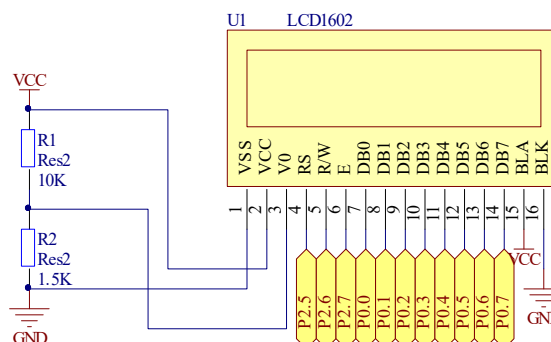

Figure 3. LCD Display Circuit Design

The expected functional indicators of this paper include the configuration of the detection efficiency for the acceleration of the three mutually perpendicular axes. The core device to be used for this target is ADXL345, which has been roughly introduced above. Here, its control circuit needs to be developed on the hardware layer. It uses IIC interface type and opens two communication pins to the outside world, Therefore, STC89C51 MCU must reasonably allocate the output and input pins to control it according to the resource configuration of the electronic pedometer system. According to the circuit schematic diagram structure in the following figure, connect the IO pin of STC89C51 MCU to ADXL345. For the hardware circuit design of ADXL345 acceleration sensor, it needs to interface with STC89C51 MCU through IIC bus and supply power. This sensor uses +5V DC voltage for power supply. As shown in the following figure, connect the +5V DC voltage to its VCC pin and ground the GND pin, Then connect the SCL pin of the ADXL345 acceleration sensor to P3.2 pin of the STC89C51 microcontroller, and connect the SDL pin to P3.3 pin. As shown in Figure 4.

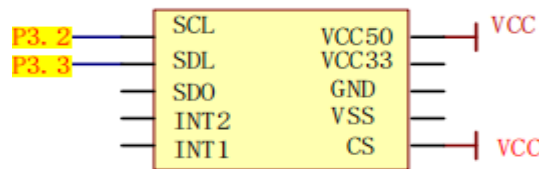

Figure 4. Circuit Design of ADXL345 Acceleration Sensor

In order to achieve the timing effect of this electronic pedometer system, it is necessary to combine the hardware circuit of this DS1302 clock chip. As shown in the circuit diagram in the figure, it can be seen that the power circuit in the DS1302 clock chip circuit is particularly simple. In terms of power circuit design, because this DS1302 clock chip has the function of backup battery, when its VCC2 pin is powered normally, the DS1302 clock chip uses the power connected to VCC2 to work, When the voltage of VCC1 is higher than the voltage of VCC2 pin after the electronic pedometer system is powered off, the DS1302 clock chip uses the backup battery connected to VCC1 to supply power, so this topic connects the positive pole of the +3.3V button battery to the VCC1 pin. In the design of clock signal circuit, the 32.687KHz crystal oscillator with high temperature characterization is directly used for driving, and its two ends are respectively connected to the X1 and X2 pins of the DS1302 clock chip. In terms of interface circuit of STC89C51 single chip microcomputer, the electronic pedometer system connects RST, IO and SCLK pins of DS1302 clock chip to P2.2~P2.4 GPIO pins of STC89C51 single chip microcomputer. Through the construction of this circuit architecture, STC89C51 MCU will finally be able to flexibly control DS1302 clock chip, so that DS1302 clock chip can achieve stable timing efficiency. As shown in Figure 5.

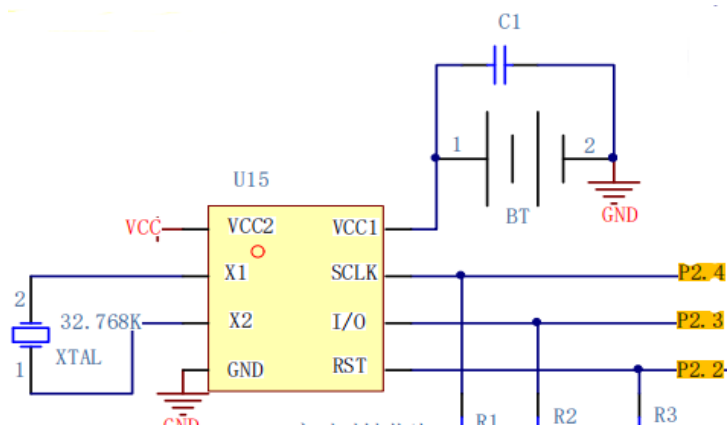

Figure 5. DS1302 Timing Circuit Design

4. System Software Design

Through the design of the work flow of each program, the action planning of the microcontroller is realized. Next, the main program of the electronic pedometer system will be developed. The microcontroller will continuously read the data output by the ADXL345 three-dimensional acceleration sensor through the IIC interface, and store the three dimensional acceleration detection results in three different arrays of X, Y and Z. Since the pedometer cannot use the Z-axis acceleration value perpendicular to the ground direction, it only processes the acceleration components in the X and Y horizontal directions. When the X and Y values are detected to have a sudden change, It means that the acceleration value is generated at the moment of the human body, and it is determined that the human body has walked a step. At this time, the step count value is increased by 1, and then the step count value data is sent to the LCD1602 LCD through the P0 port for display, realizing the real-time display of the steps. Next, the system will build a three wire serial port through the three pins P2.2~P2.4 to read the time data in the DS1302 clock chip. After reading, the time data will be sent to the LCD1602 LCD screen through the P0 port for display.

In order to achieve the LCD indicators in the system functional indicators, this part will start to research and develop the control process of the LCD screen LCD1602. It can be seen from the detailed review of official materials that the most mature driver scheme is to achieve the internal LCD master controller, LCD lattice plate, voltage processor The control of parallel bus interface, character library memory and other hardware drive circuit modules enables STC89C51 MCU to control LCD1602 LCD screen to work normally through its input/output interface. In the control process of LCD1602 LCD screen, the parallel interface between STC89C51 MCU and LCD1602 LCD screen is the key point of data communication. This interface needs to be driven by software programs, The input and output pins of STC89C51 single chip microcomputer are used for building, and data communication is conducted with RS, RW, EN and DB0~DB7 of LCD1602 LCD screen. Next, the work flow of the control subprogram is introduced through the software work flow chart.

In the index design requirements of this paper, it is necessary for the electronic pedometer system to be able to achieve the goal of detecting the acceleration of three mutually perpendicular axis directions. On the software level, it needs to be realized through the control subprogram of STC89C51 single chip microcomputer to ADXL345, combined with IIC communication protocol. As shown in the flow chart in the following figure, through a for cycle with a repetition number of 8, after each cycle starts, STC89C51 single chip microcomputer needs to first send the lowest bit of byte data to be written to SDA pin through P2.3 pin. STC89C51 single chip microcomputer then pulls up the SCL pin through P2.2 pin, waits for 5 microseconds, then P2.2 pin immediately pulls down the SCL pin, waits for 5 microseconds again, thus completing the bit data writing cycle, and then repeats the operation for 7 consecutive times, The STC89C51 single chip microcomputer can write a complete byte data to the ADXL345 acceleration sensor.

The bottom hardware circuit of the DS1302 clock chip has been designed and developed above. This chapter will start to design its control process. Through a detailed review of official materials, we can know that when STC89C51 MCU and DS1302 clock chip are used together, STC89C51 MCU needs to build a subprogram flow of write time and read time in the software system. According to the requirements of the drive timing, The STC89C51 single chip microcomputer and the DS1302 clock chip use a three wire serial bus for communication. The time data reading process is mainly to complete the acquisition of the current timing data. According to the workflow in the following figure, the STC89C51 single chip microcomputer first needs to output a high level through P2.2 pin, pull up the RST pin, and then the STC89C51 single chip microcomputer executes the byte writing process to write the address of the register

to be read, Then immediately execute the byte reading process, acquire the current timing information stored in this register, and then output the low level to RST pin through P2.2 pin, output the low level to IO pin through P2.3 pin, and output the low level to SCLK pin through P2.4 pin. The time data can be read through the operation of this protocol.

5. Conclusion

During the design process, each necessary circuit can be designed independently, leading out high-performance data interfaces, enabling each module circuit to achieve docking, and stable and fast communication. Finally, the electronic pedometer system can operate stably and efficiently, which can reduce the difficulty of designing this electronic pedometer control system, This kind of design scheme used in this project also simplifies the difficulty of problem troubleshooting to a certain extent, and can also help improve and optimize later. The electronic pedometer control system configured in this project has a high cost performance ratio, which can achieve high performance. All expected functional indicators have achieved very good performance. After many times of optimization and maintenance, the following functional indicators can be effectively implemented: high-definition display parameters, 3D acceleration acquisition and RTC timing.ents

References

- [1] Xu Yonglong, Principle and Application of Single Chip Microcomputer [M], China Machine Press, January 2014.
- [2] Huang Jieyong. AltiumDesigner Basic Course [M]. Electronic Industry Press. 2015. 2.
- [3] Li Zhensheng, Basic Course of Electronic Technology [M]. Beijing, National Defense Industry Press, October 2016.
- [4] Xu Rengui, Liao Zhezhi, Monolithic Microcomputer Application Technology [M], China Machine Press, November 2014.
- [5] Ma Zhongmei. C Language Application Program Design of Single Chip Microcomputer [M], Beijing University of Aeronautics and Astronautics Press, 2019.
- [6] Huang Xianwu, Zheng Xiaoxia. Sensor Principle and Application [M]. Chengdu: University of Electronic Science and Technology Press, June 2016.