

Study on Electrical Services and Control for Heating, Ventilation and Air-conditioning in Buildings

Liwei Fang

Wenzhou Polytechnic, Wenzhou 325035, China

Abstract

In modern age of technology, the concept of energy saving and environmental comfort raise the building services and controls as a significant issue during the design, installation, operation and management. Proper electrical services and sound control systems, especially for Heating, Ventilation and Air-conditioning (HVAC) sections, can not only make our lives more convenient and pleasant, but also increase the energy efficiency in the view of sustainable development.

Keywords

Electrical Services; Control System; HVAC.

1. Introduction

The purpose of HVAC system is mainly to provide comfortable internal condition for occupants or is sometimes for other requirements, such as storage. Thus, the building service engineering turns out to be rather vital. In this report, take central hydronic heating system with fully pumped using radiators as emitters in small houses or flats as a example, it will first briefly describe the objective and operation of the system chiefly in domestic application, then use various diagram and figures to illustrate the electrical services, finally explain the components and process of control system, as well as the criteria of the controller selection.

2. System Description

The central hydronic domestic heating system is aimed at adjusting the room temperatures through the heat transfer, including convection, conduction and radiation. The heat instantly produced is principally for target building to improve the thermal comfort. The amount of the heat released is primarily based on the hot water flow rate in the pipes. In reality, the heating system is often combined with hot water supply system, which is used for washing, shower and etc.

Each room in the house should be at least installed one radiator with regulating valve, which decides the flow rate. There are two type of control available in this case. Manual control is the simple approach depended on the human sense and achieved by directly human operation. The other improved automatic control is the motorised valves, which connects a thermal sensor in the target room (1). This is more commonly applied in the house since some heating zone expose to south, which means more solar heat gain and less demanded artificial heat. Therefore, it enables to match the heating requirement in individual zone. The hot water source is the boiler generally located at the roof or in groundfloor, which would consume electricity to increase the water temperature to a certain degree. Another electrical element in the heating system is the pump. It plays an essential role to push water to move and alter the flow velocity. The equipments mentioned above are the basic components during the system operation process and service performance.

When the water temperature in the boiler is ready and the reference temperature is set appropriately, resident can open the valve and allow the pumped hot water flow in the supply

pipes. After passing the control valve, the flow rate is changed to ensure the needed quantity and continues to run into the radiators. The large contact surface of the radiators gives the opportunity to transfer heat between the hot water and the relatively cool surrounding air. Thereafter, the room temperature grows gradually and the temperature sensor receives the information of temperature change (during heating period the difference between set point temperature and room temperature should reduce) and response it to the controller. And then the controller can send the signal to valve, leading to open or close. The flow rate, hence, changes and carries on heating supply. Some time later, the environmental temperature should be more and more close to reference temperature. Simultaneously, the valve tends to be fully closed. If the temperature difference enlarges again, the valve will re-open to introduce the inflow. Consequently, the zone temperature will fluctuate and maintain in a certain level near the set point temperature, in which condition people will feel ease and comfortable since the initial set temperature is according to human sense.

A simple sketch of the domestic heating system, regardless of the exact positions in the house, is displayed below in Figure 1. This only shows the relationship and connection between the fundamental components (here to make the figure clearly, only one radiator is drawn here. The number of radiators relies on the number of rooms or zones and the sketch is similar but with additional same part of one terminal unit. The other figures follow the same rule).

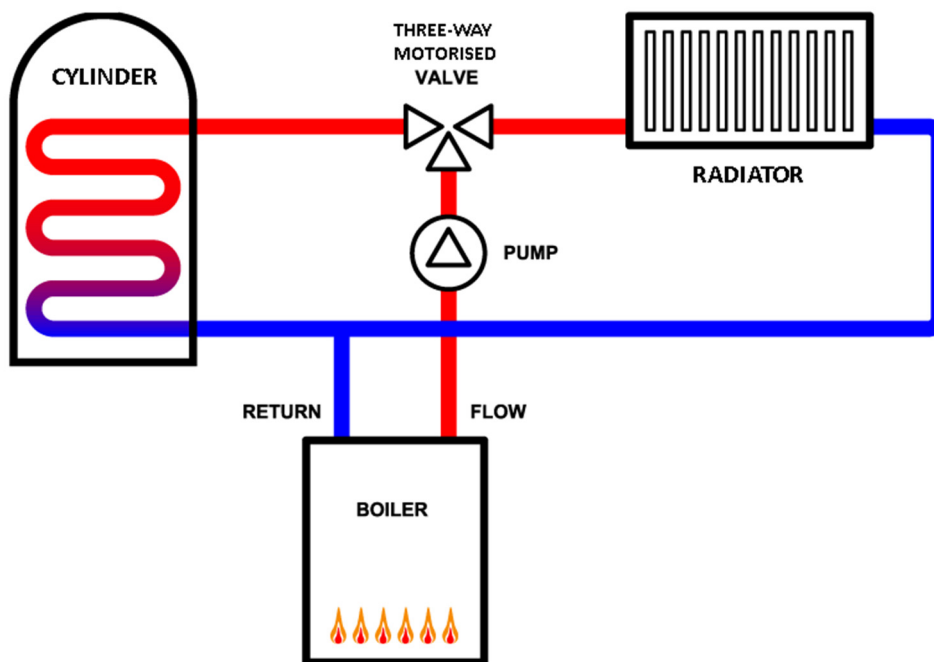

Figure 1. Simple sketch of heating system

3. Electrical Services

In this basic type of heating system, four components, namely boiler, thermostat, pump and motorised valves with room thermostat are electrically operated. There are two types of power circuit in buildings, ring circuit and radial circuit. It is suggested that ring circuit is more promoted for that every socket in circuit can be provided electricity without the disturbance from others, for example, if one part of socket circuit is broken, the rest will not be damaged in this case. Compare and contrast Figure 2 and Figure 3, the advantage of ring circuit over radial circuit is obvious.

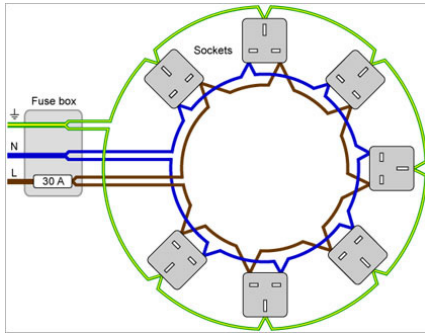

Figure 2. Ring circuit

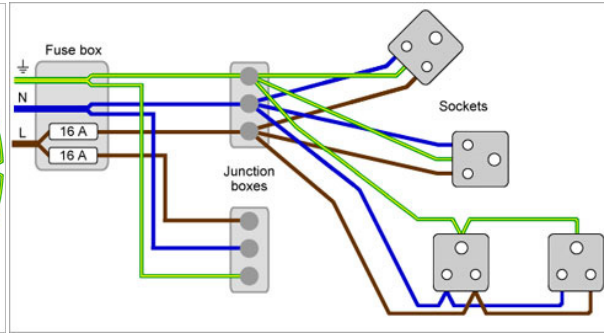

Figure 3. Radial circuit

The loads on the ring circuit only contain electrical components of heating system (which will be emphasized heavily in following content). They may be an independent circuit connecting to the unit consumer. Other normal appliance, such as lights and computers, even though seems to be no direct link with heating system. However, they can make contribution to the heat gain, and thus reduce the heating load. In other words, to some extent, this part of electrical devices can influence the control of heating system.

Now concentrate on the major section: the electrical powered circuits and components of the system and type of wiring to the building’s electricity supply. See Figure 4 of the wiring diagram below.

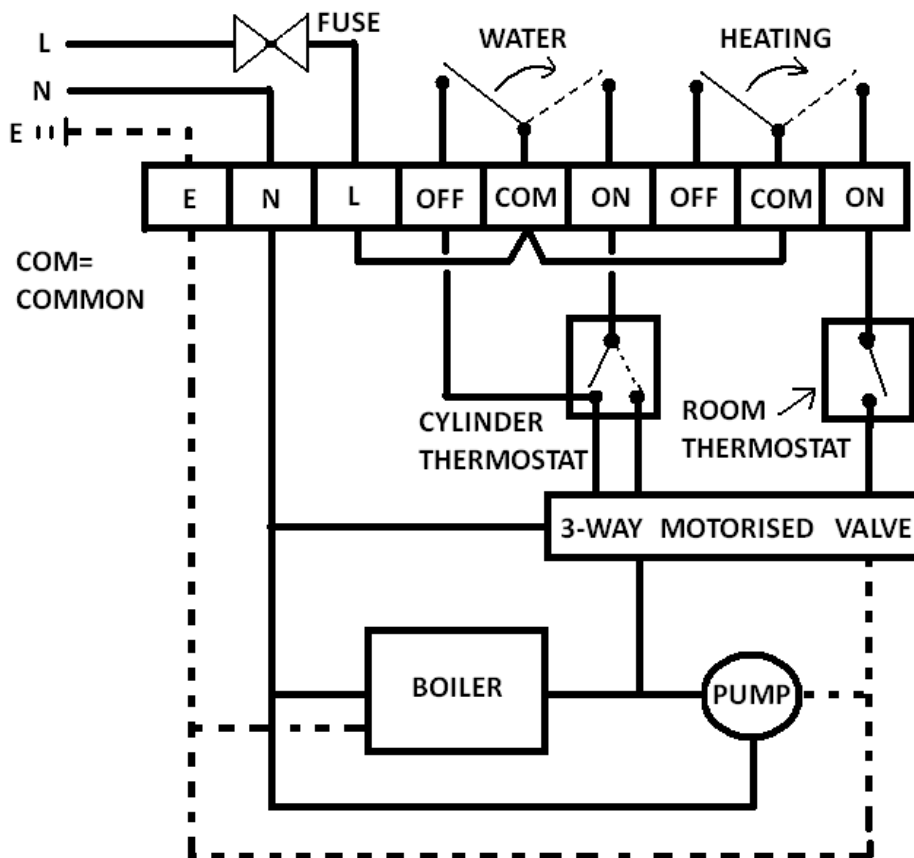

Figure 4. Wiring diagram of heating system

According to the diagram, three lines: live, neutral and earth, connect to the electrical appliances of the heating system. Commonly, the domestic heating system would be combined with the hot water supply system, which means the hot water from boiler would satisfy both the heating requirement and hot water need. As a result, the water supply for domestic usage

appears in the diagram as well. Furthermore, merely one heating point is raised here, giving a transparent understanding of the connection structure. If the number of radiators increases, just add the same connection structure of heating point.

In the diagram, one simple electrical protection device, 3A fuse, is equipped in the live wire to avoid the sudden occurrence of short circuit.

During the cold winter, after switch on the heating system, the boiler use the electricity to heat the cold water and then store in the cylinder at a certain temperature degree, which is prepared for following heating purpose. There is also an electrical thermostat in the cylinder, which is strapped to the side of the calorifier and gives response to motorised valve. As the name called “motorised valve”, it consumes electricity to alter the opening size which therefore determine the flow rate (2). The pump also electrically functions to force the pipe water to move into radiators through corresponding valves.

4. Control Services

From the previous description, since there is feedback (sensing element), it is a closed control loop system. One simple sketch of one heating terminal in Figure 5 shows the final entry of hot water into radiator.

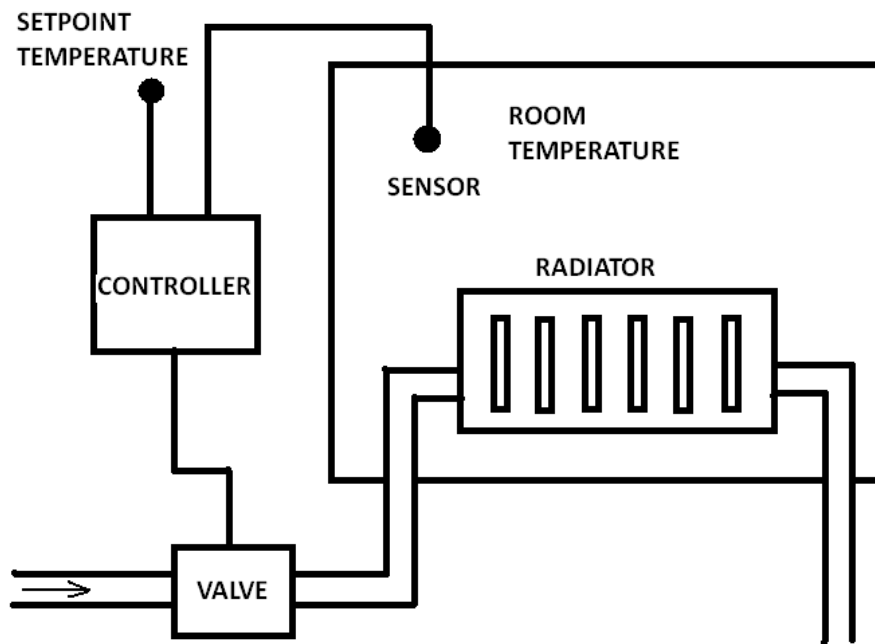

Figure 5. Simple heating terminal structure

The following Table 1 gives the definitions of several significant terms in heating system. Block diagram of the control system is in Figure 6.

Despite various types of industrial controllers, this diagram for particular heating system indicates the Proportional - Integral (PI) controller, which transparently means the combination of Proportional controller and Integral controller (5). This feature can be also seen from the equation: $u(t) = K_p e(t) + \frac{K_i}{T_i} \int_0^t e(t) dt$.

Table 1. Definitions of heating system terms

Term	In heating system	Definition
Controller	The device that provides a signal to the valve	The device that provides a signal to the controlled device in response to feedback from the sensor
Sensor	Room air temperature sensor	The device that measures the room temperature
Controlled device	The motorised valve	The device that changes the operation of the process plant in response to a control signal
Controlled variable	The room air temperature	The signal that the sensor senses
Process/ Plant	The radiator	The device that produces the change in the controlled variable
Input signal (setpoint)	Setpoint	This is the reference or desired input that is compared to the controlled variable

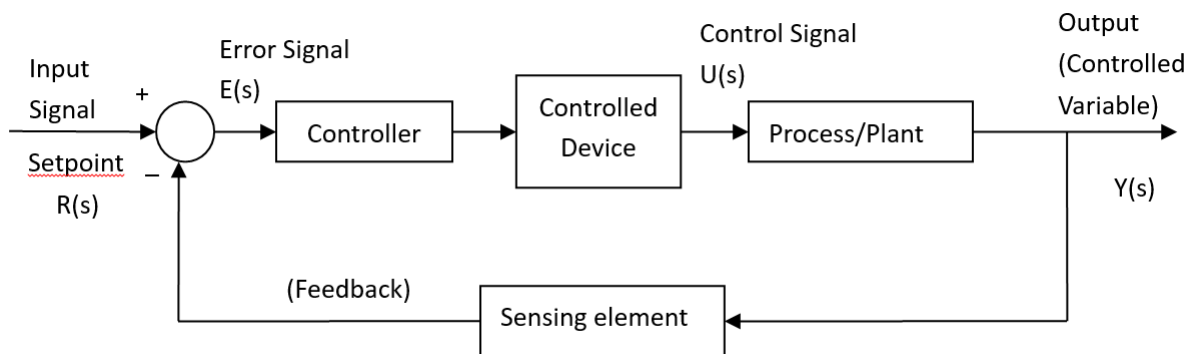

Figure 6. Block diagram of closed control loop

And the PI controller transfer function is: $G(s) = \frac{U(s)}{E(s)} = K_p + \frac{K_i}{T_i s}$.

PI controller is most commonly used in HVAC systems in spite of the complexity over the Proportional only controller or Integral only controller (4). On the one hand, the Proportional control can decrease the overshoot and undershoot over time. On the other hand, the Integral control improves the steady state response. There is no need to add the Derivative controller in this system since it has a very fast response but most heating system responses are comparatively slow. In other words, the value of Derivative control in most heating system performance is minimal (5).

Refer to Figure 6 again. The hot water flow through the pipes, whose amount is controlled by the valves. So the working radiators can release heat energy to the surrounding and increase its temperature. The thermal sensor placed in the room can sense this and send the information to the controller and therefore controller will compare the setpoint and the recorded temperature to find the difference. Depending on this, the controller will command the motorised valve to open or close. Accordingly, the hot water flow, which can change the heat emitted, will alter. Like a cycle, the room temperature will begin to oscillate but will indefinitely approach to a certain degree, which is the most suitable for the residents. This is another reason to choose the PI controller comparing to the Two position controller, because the later

controller only have the valve fully open or fully closed, leading to that the room temperature will fluctuate between a differential gap (backlash) and cannot finally be a constant as setpoint.

5. Conclusion

The electrical service and control system are so essential and important to our daily life that we should acquire a basic understanding. This short report ultimately introduces them by taking the central hydronic heating system in domestic use as an example to show the simplest method and operation. The electrical appliances in the system are boiler, thermostat, motorized valve and pump, which can be connected in ring circuit without the external interference. It is a closed loop control system applying the PI controller. It is very popular and is widely used in relatively cold places. During the operation period, even if the output variable (room temperature) will be overshoot and the response will be relatively slow due to the feature of heating system, the final result will turn out to be a constant temperature and satisfied to occupants. In a word, the fundamental concept and knowledge of electrical services and control systems in HVAC system is roughly raised in this report and need further deep study, promotion and improvement.

References

- [1] Greeno, R. (2006) *Building Services, Technology and Design*. London: Pearson Longman
- Montgomery, R. & McDowall, R. (2009) *Fundamentals of HVAC Control Systems*. SI Edition. New York: Elsevier.
- [2] Bandhauer, T.M., Garimella, S., and Fuller, T.F. (2011). A Critical Review of Thermal Issues in Lithium-Ion Batteries. *J. Electrochem. Soc.*, 158(3), R1–R25.
- [3] Chen, Y., Kwak, K.H., Kim, J., Kim, Y., and Jung, D. (2021). Energy-efficient cabin climate control of electric vehicles using linear time-varying model predictive control. *Optim. Control Appl. Methods*, 1–25.
- [4] Farrington, R.B., Rugh, J.P., and Barber, G.D. (2000). Effect of Solar-Reflective Glazing on Fuel Economy, Tailpipe Emissions, and Thermal Comfort. In *SAE Technical Papers*, No.2000–01–2694.
- [5] Glos, J., Solc, F., Otava, L., and Vaclavek, P. (2020). Hybrid Model Predictive Control for Fully Electric Vehicle Thermal Management System Optimal Mode Selection. In *IECON 2020 The 46th Annual Conference of the IEEE Industrial Electronics Society*, 2036–2043. IEEE, Singapore, Singapore.