

Optimization Design of Food Slicer

Xinjian Xu

Shandong Xiehe University, China

Abstract

A new type of food slicing machine was developed to solve the problems of high cost and high energy consumption of existing food slicing machines. The slicer can achieve rapid cutting of various foods, with the advantages of small vibration, low energy consumption, simple operation, safety and efficiency, and uniform cutting.

Keywords

Slicer; Automatic Adjustment; Uniform Cutting.

1. Introduction

Currently, the existing food slicing machines use the weight of the material as the power to send the material into the slicing machine, resulting in accidents of being caught by the machine during the food processing process. Moreover, the function is single, and the processing efficiency is low. Based on the existing food slicing machines, this article proposes a fast and versatile food slicing machine with an automatic adjustment mechanism that can uniformly cut.

2. Overall Structure

The fast multi-purpose food slicing machine uses fully transparent organic glass as the outer shell, and is mainly composed of a base, a motor, a reducer, an automatic feeding and adjusting mechanism, and a slicing mechanism, as shown in Figure 1.

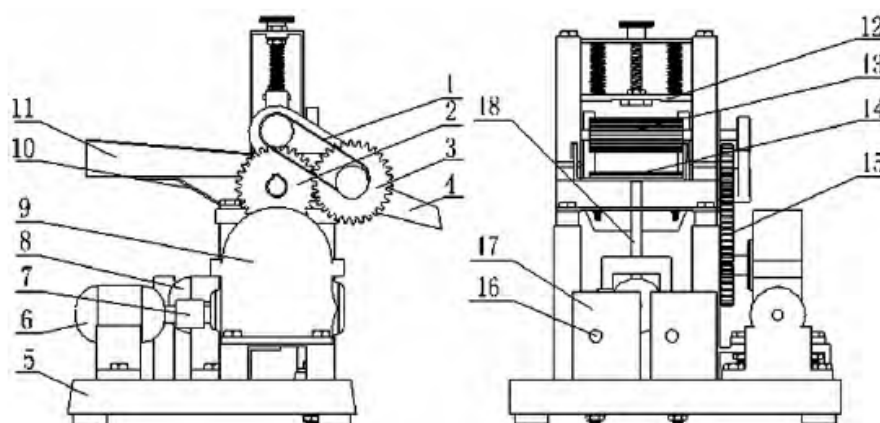

- 1.Belt 2.Lower feeding roller left end gear 3.Driven gear 4.Material outlet slot 5.Machine base
- 6.Motor 7.Coupling 8.Motor 2 9.Reducer 10. Support rod 11.Material conveying trough
- 12.Automatic feeding and automatic adjustment mechanism 13.Upper feeding pressure roller
- 14.Lower feeding pressure roller 15.Driving gear 16.Adjusting knob 17.Speed regulating switch 18. Slicing mechanism

Figure 1. Structural Diagram of Food Slicer

During the operation of motor 1, the reducer is connected through a coupling, and the driving gear and the left end gear of the lower feeding roller drive the lower feeding pressure roller to rotate. The upper feeding pressure roller and the lower feeding pressure roller are connected

through a linkage mechanism composed of the left end gear, driven gear, and belt of the lower feeding roller, which can achieve the simultaneous rotation of the two pressure rollers, thereby driving the automatic feeding and automatic adjustment mechanism. When the motor 2 is working, it drives the slicing mechanism to perform linear reciprocating motion, which can adapt to the slicing requirements of various materials.

3. Design of Key Components

3.1. Automatic Feeding and Automatic Adjustment Mechanism

As shown in Figure 2, the automatic feeding mechanism consists of three equally large gears, pulleys, belts, positioning links, upper and lower feeding pressure rollers, automatic adjustment springs, and manual adjustment rods.

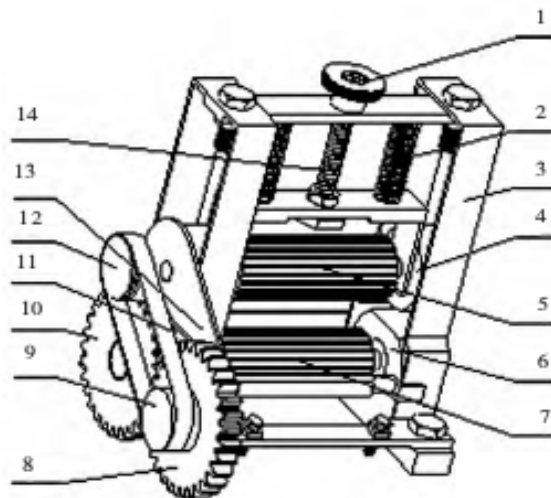

- 1.Manual adjustment lever 2.Automatic adjustment spring 3.Positioning bracket 4.Movable bearing 5.Upper feed pressure roller 6. Fixed bearing 7. Lower feed pressure roller 8.Driven gear 9.Belt pulley 10.Left end gear of lower feed pressure roller 11.Inter gear positioning link 12. Belt pulley 13.Positioning link 14.Positioning screw

Figure 2. Automatic feeding and automatic adjustment mechanism

During normal operation, the driving gear meshes with the left end gear of the lower feeding roller, and the left end gear of the lower feeding roller meshes with the driven gear. The two gears meet the meshing conditions. The positioning connection between the two gear shafts is achieved by a positioning link between the gears. The pulley 1 coaxial with the driven gear and the pulley 2 coaxial with the upper feeding pressure roller are connected through a belt. The power of the driving gear drives the simultaneous rotation of the upper feeding pressure roller and the lower feeding pressure roller, Realize automatic feeding of materials. When placing materials, it is necessary to apply a certain amount of force manually. When the materials are caught by the teeth of the upper and lower pressing rollers, the directional conveying of materials is achieved.

The upper end of the upper feed pressure roller is connected to the positioning screw of the manual adjustment lever, which passes through the upper end of the positioning bracket and is equipped with an adjustment knob at the top. There is an automatic adjustment spring on both sides of the manual adjustment lever. The lower end of the automatic adjustment spring is connected to the upper end of the upper feed pressure roller, and the upper end of the automatic adjustment spring is connected to the top end of the positioning bracket. The automatic adjustment spring can automatically adjust the spacing between the upper and lower feeding pressure rollers according to the size of the material (adjustment range: 0~10mm),

which not only ensures that the pressure roller has a certain pressure on the material and the feeding is smooth, but also avoids material damage and deformation.

3.2. Slicing Mechanism

The slicing mechanism is composed of a crank, a sliding groove, a slider, a tool holder, and a cutter. The crank is connected to the motor 2 shown in Figure 1, as shown in Figure 3. The sliding groove is connected to the tool holder through a movable rod. Driven by the motor 2, the rotary motion of the crank is converted into left and right movement of the slider 5, thereby driving the movable rod to move up and down to achieve cutting of the tool. The tool is mounted on a tool holder located below the material outlet slot. When working, adjust the rotational speed of the stepless speed regulation motor as needed to obtain different cutting speeds. The cutter design adopts a linear reciprocating type, which changes the traditional disc cutter design to make up for the lack of a single function of the slicer on the market; Moreover, the tool is easy to disassemble and replace, and convenient to use and maintain.

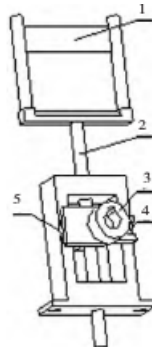

1. Cutter 2. Movable rod 3. Crank 4. Sliding groove 5. Slider

Figure 3. Slicing mechanism

4. Conclusion

The food slicing machine designed in this study uses an automatic feed adjustment mechanism, making it convenient and safe to cut; Adopting a linear reciprocating cutting tool and a stepless speed regulation dual power system, it can be applied to uniform slicing of materials of different specifications and thicknesses, truly realizing a multi-purpose machine; The overall structure of the machine is compact, small in size, easy to move and store, beautiful and generous, easy to maintain and repair, filling the gap in high-quality food slicing machinery in the catering industry, and has high promotion and application value.

Acknowledgments

(Shandong Province University Science and Technology Plan Project, No. J18KB043).

References

- [1] Zhu Keqing, Lv Shaofang. Research and design of an automatic slicing machine for steamed buns [J]. Grain Processing, 2018, 37 (3): 49-50.
- [2] Shi Pengtao, Wen Huaixing, Wang Ningxia. Design and experimental analysis of a fully automatic jujube conveying directional slicer [J]. Agricultural Mechanization Research, 2019, 35 (11): 171-175.
- [3] Design of an edible betel nut slicer [J] Chen Yang; Chen Zhishui. Hubei Agricultural Science, 2018 (16).